

Dear Students,

Teachers always motivate and guide the students to learn all the content of the book so that scoring highest in the exams is ensured, still some students lag behind when it comes to effective preparation of the Chemistry subject and many find it tough to decide what to revise just before the final exam.

An effort has been made to select the most repeated short questions and highlights of long questions which students need to keep in their mind before appearing for the final exam. Under some topics you will find the statement written **LONG QUESTION** and then you will see some short questions. Learning the answers to those short questions will help you learn good portion for long question. Long questions are given in minimum possible length. This will enable you to avoid getting no credit for answer to any question. Getting reasonable marks is better than getting no marks. In every answer, some words have been kept in **bold** font style. Combining those words will give you the key words to remember so you may never fail in attempting any question correctly. It may help you in learning the shortest answer so there are no blank sheets left by you in the answer book.

The total of 332 pages excluding glossary of your textbook have been reduced to 104 pages. Make sure that it is a preparation material for those who, due to many reasons, couldn't touch the book even. Moreover, it is meant to help in last moment revision plan. Once you have memorized all the content given in this book you are encouraged to learn the chapters thoroughly. You are advised to prepare from all the files which are available on the www.pakcity.org website

Teachers always wish and strive to see their students achieving their best and heading towards their goals successfully. Prayers for your glorious future. Amen.

The Study Material is Given According to the Latest Pairing Scheme of All Punjab Boards.

God Bless You!

Sr. No.	Chapters	Page No.
1	1	1-7
2	2	8-10
3	3	11-22
4	4	23-35
5	5	36-51
6	6	52-67
7	7	68-75
8	8	76-82
9	9	83-89
10	10	90-96
11	11	97-104



Chapter 1

Basic Concepts

History of Atom

- Democritus gave the word “**atomos**” for atoms meaning **indivisible**.
- John Dalton gave atomic theory saying that matter is composed of atoms of different elements which differ in their properties.
- **Electron, proton, neutron** recognized as **fundamental particles** of atoms.
- **J. Berzelius** gave the system of **giving symbols to elements** as well as determined **atomic masses** of elements.

Evidence of Atoms

- An **ordinary microscope** measures the size of an object up to or above **500 nm** ($1\text{nm} = 10^{-9}\text{ m}$).
- Objects of the size of an **atom** are **observed** using **electron microscope**.
- **Diameter** of atoms is of the order of **$2 \times 10^{-10}\text{ m}$ (0.2 nm)**.
- **Masses** of atoms range from **10^{-27} to 10^{-25} kg** .
- **$1\text{ amu} = 1.661 \times 10^{-27}\text{ kg}$** .

Atom, Molecule, Ion, Molecular Ion

Q. Define atom.

Atom is the smallest particle of an element whereas molecule is the smallest particle of a pure substance (compound).

Q. Define ion. How cation and anion are formed?

Any specie carrying a charge is called an **ion**. It can be a **cation** (Na^+) or an **anion** (Cl^-) which is formed by **endothermic** and **exothermic** process, respectively.

Q. How molecular ions are formed?

When a molecule loses or gains an electron a **molecular ion** is formed. They are formed by **passage of α -particles or X-rays through a gas**. Cationic ones are more than anionic ones. Examples, CH_4^+ , CO^+ , N_2^+ .

Relative Atomic Mass

Q. Define relative atomic mass.

The atomic mass of an atom of an element as compared to the mass of carbon-12. Example, H (1.008 amu), O (15.9994 amu)

Isotopes

Q. Define isotopes. Give two examples.

Isotopes are atoms of an element having same atomic number but different mass number.

Hydrogen has three (H-1, H-2, H-3), **carbon has three** (C-12, C-13, C-14), **Oxygen has three** (O-16, O-17, O-18), **nickel has five**, **calcium has six**, **palladium has six**, **cadmium has nine**, **tin has eleven isotopes**.

Q. Why isotopes have same chemical properties but different physical properties?

Isotopes have same chemical properties because their atomic number is same which tells about electronic configuration. They have different physical properties because their atomic mass is different.

Points to remember about isotopes

- **280 different isotopes** occur in nature.
- **40 are radioactive isotopes** out of 280.
- **300 unstable isotopes** have been produced through artificial disintegration.

- Elements with **even atomic number** and those with **atomic masses as multiples of four** have **greater isotopes** as compared to elements with odd atomic number which never possess more than two stable isotopes.
- **154** out of 280 have **even atomic number** and **even mass number**.

Q. How does no individual neon atom in the sample of the element has mass 20.18 amu?

Ans: Neon has three isotopes of atomic masses 20, 21 and 22 with relative abundances as 90.92%, 0.26% and 8.82%

$$\text{Average atomic mass} = \frac{20 \times 90.92 + 21 \times 0.26 + 22 \times 8.82}{100} = 20.18 \text{ Answer}$$

Mass Spectrometry

Q. Define mass spectrometer.

Mass spectrometer is an instrument which is used to measure exact masses of different isotopes of an element.

Q. Mention types of mass spectrometer.

It has two types: i. Dempster's mass spectrometer ii. Aston's mass spectrograph

Q. Mention principle or working of mass spectrometer.

Working

- The substance is first volatilized in volatilization chamber (**pressure 10^{-6} to 10^{-7} torr**).
- The vapours are ionized by fast moving electrons in ionization chamber.
- The ions are accelerated through an electric field with perforated plates (**500-2000 V**).
- The ions are passed through a magnetic field and divided into groups based on their m/e ratio.

Mathematical Relation

$$m/e = H^2 r^2 / 2E$$

- The groups of ions fall on the electrometer (**ion collector**) and produce a minute electric current.
- The signals are passed through the amplifier and finally recorded as a **mass spectrum** with mass number along x-axis and relative abundance along y-axis.

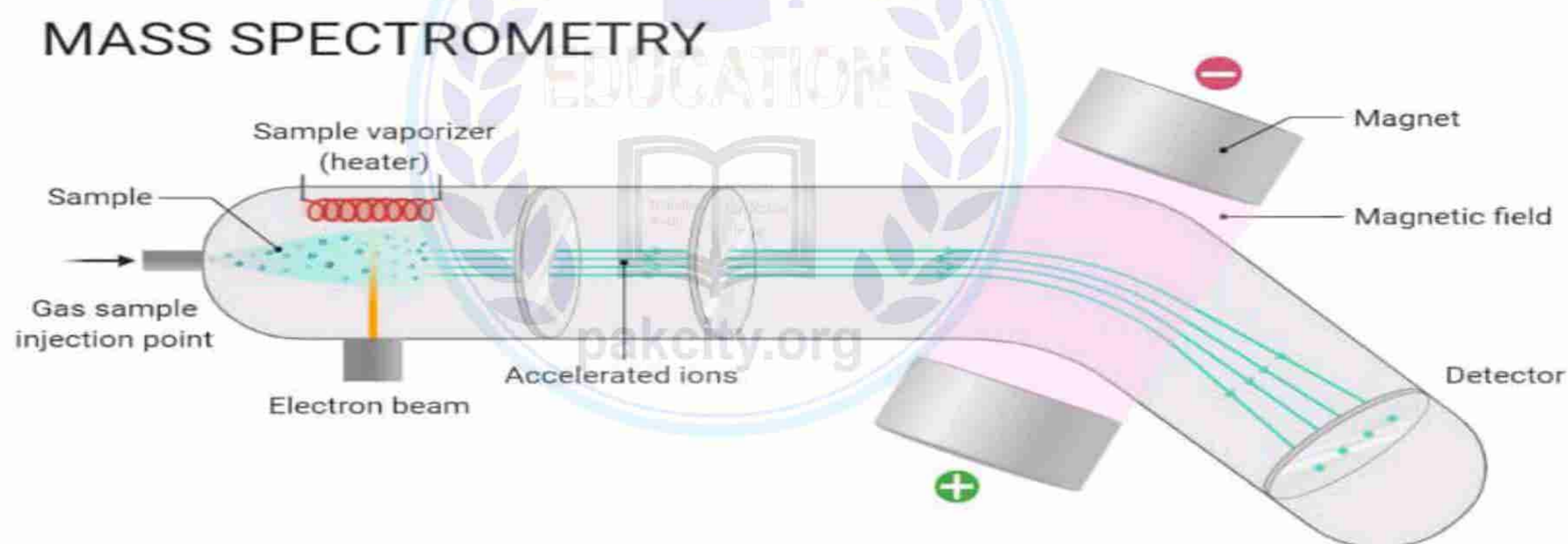

Average Atomic Mass

Q. Define average atomic mass.

Average atomic mass is calculated for getting the average of the atomic masses of all the isotopes of an element.

Percentage of an Element

Q. How percentage of an element is determined?

Percentage of an element =

$$\text{Mass of the element in the compound} / \text{Mass of the compound} \times 100$$

Empirical Formula and Molecular Formula

Q. Define empirical formula and molecular formula.

Empirical formula is the simplest formula that gives the small whole number ratio between the atoms of different elements present in a compound whereas molecular formula gives the actual number of atoms of different elements present in one molecule of a compound.

For example,

CH (benzene empirical formula), C₆H₆ (benzene molecular formula)

CH₂O (glucose empirical formula), C₆H₁₂O₆ (glucose molecular formula)

$$\text{Molecular formula} = n \times \text{Empirical formula}$$

$$n = \text{Molecular formula} / \text{Empirical formula}$$

Q. What are the steps to determine empirical formula?

Steps to determine empirical formula

Find:

i. Percentage composition

ii. Gram atoms

iii. Atomic ratios

iv. If atomic ratios not whole numbers multiply with a suitable digit

Q. How empirical formula is determined for compounds made of carbon, hydrogen and oxygen?

Empirical formula is determined through combustion analysis for organic compounds made of carbon, hydrogen and oxygen. A weighed quantity of compound heated in furnace.

• **H₂O absorber-----Mg(ClO₄)₂**

• **CO₂ absorber----- 50% KOH**

$$\% \text{ of carbon} = \text{Mass of CO}_2 / \text{Mass of organic compound} \times 12.00 / 44.00 \times 100$$

$$\% \text{ of hydrogen} = \text{Mass of H}_2\text{O} / \text{Mass of organic compound} \times 2.016 / 18 \times 100$$

$$\% \text{ of oxygen} = 100 - (\% \text{ of carbon} + \% \text{ of hydrogen})$$

Mole, Avogadro's Number, Molar Volume

Q. Define mole and Avogadro's number. OR What is the relation between mole and Avogadro's number?

The atomic mass, molecular mass, formula mass, ionic mass of a substance expressed in grams is called mole. It is denoted by n.

$$\text{Number of moles} = \text{Mass} / \text{Molar mass}$$

The number of particles (atoms, molecules, ions, formula units) in one mole of the substance is equal to 6.02×10^{23} . It is called Avogadro's number denoted by N_A.

$$\text{Number of particles} = \text{Mass} / \text{Molar mass} \times N_A$$

$$\text{Number of particles} = \text{Number of moles} \times N_A$$

1 mole of H₂ = 2.016 g = 6.02×10^{23} molecules of H₂

1 mole of Na = 23 g = 6.02×10^{23} atoms of Na

1 mole of OH⁻ = 17 g = 6.02×10^{23} ions of OH⁻

1 mole of NaCl = 58.5 g = 6.02×10^{23} formula units of NaCl

Q. Define molar volume (V_m).

One mole of any gas at STP occupies a volume of 22.414 dm³. This is called molar volume denoted by V_m.

For example,

1 mole of H₂ = 2.016 g = 6.02×10^{23} molecules of H₂ = 22.414 dm³

Q. Why sizes and masses do not affect volume?

The distance between the gas molecules is 300 times greater than the diameter so sizes and masses do not affect the volume.

Stoichiometry

Q. Define stoichiometry.

Stoichiometry is a branch of chemistry which deals with the quantitative relationship between reactants and products in a balanced chemical equation.

Q. What are the assumptions of stoichiometry?**Assumptions**

All the reactants are completely converted to products.

No side reaction occurs.

Q. Which laws are obeyed in stoichiometry?

Law of conservation of mass and law of definite proportions obeyed.

Q. Which relationships are studied in stoichiometry?**Relationships**

- Mass-mass relationship
- Mass-mole relationship
- Mass-volume relationship
- Mole-mole relationship

Limiting Reactant**Q. Define limiting reactant. Give an example.**

Limiting reactant is a reactant that controls the amount of the product formed in a chemical reaction due to its smaller amount. For example, in burning of wood, wood is the limiting reactant and oxygen is in excess.

Q. What are the steps to identify a limiting reactant?**Steps to identify limiting reactant**

Find:

- i. Number of moles of reactants
- ii. Number of moles of products
- iii. Reactant giving less amount of product is the limiting reactant

Yield**Q. Difference between actual yield and theoretical yield.**

The amount of the product in real in a chemical reaction is actual yield, whereas, the amount of the product obtained from balanced chemical equation is theoretical yield.

Q. Why actual yield is less than theoretical yield?

Actual yield is always less than theoretical yield due to:

- i. Inexperienced worker
- ii. Mechanical loss during filtration, distillation, washing, drying, crystallization and separation with separating funnel
- iii. Side reactions
- iv. Incomplete reaction

Q. How efficiency of a reaction is determined? OR What is percentage yield?

$$\% \text{ yield} = \text{Actual yield} / \text{Theoretical yield} \times 100$$

Selective Short Questions (Numericals)

1. Why do 2 g of H₂, 16 g of CH₄, 44 g of CO₂ occupy separately the volume of 22.414 dm³ although the sizes and masses of molecules of three gases are very different from each other?

Ans: One mole of any ideal gas at STP occupies a volume of 22.414 dm³. The distance between the gas molecules is 300 times greater than the diameter, therefore, the sizes and masses of different gases do not affect the volume.

2 g of H₂ = 1 mole = 6.02 × 10²³ molecules = 22.4 dm³ at STP

16g of CH₄ = 1 mole = 6.02 × 10²³ molecules = 22.4 dm³ at STP

So, they occupy a volume of 22.414 dm³ which is called molar volume (V_m).

2. Calculate the mass in grams of 2.74 moles of KMnO₄.

Ans: Given

Moles of $\text{KMnO}_4 = 2.74 \text{ mol}$

Required

Mass in grams of $\text{KMnO}_4 = ?$

Solution

Formula Applied

$$n = \frac{\text{Given mass}}{\text{Molar mass}}$$

$$\begin{aligned} \text{Mass of } \text{KMnO}_4 &= \text{No. of moles} \times \text{Molar mass} \\ &= 2.74 \times 158 \\ &= 432.9 \text{ g} \end{aligned}$$

3. Calculate the number of moles of oxygen atoms in 9 moles of $\text{Mg}(\text{NO}_3)_2$.**Ans:**

$$\text{Molar mass of } \text{Mg}(\text{NO}_3)_2 = 24 + 28 + 96 = 148 \text{ g/mol}$$

Given

Mass of $\text{Mg}(\text{NO}_3)_2 = 9 \text{ g}$

Required

Moles of oxygen atoms = ?

Solution

Formula applied

$$n = \frac{\text{Given mass}}{\text{Molar mass}}$$

$$\begin{aligned} \text{Moles of } \text{Mg}(\text{NO}_3)_2 &= 9 \text{ g} / 148 \text{ gmol}^{-1} \\ &= 0.061 \text{ mol} \end{aligned}$$

$$\begin{aligned} 1 \text{ mol of } \text{Mg}(\text{NO}_3)_2 &\text{ contains oxygen} = 6 \text{ mol} \\ 0.061 \text{ mol moles of } \text{Mg}(\text{NO}_3)_2 &\text{ contain oxygen} = 6 \times 0.061 \\ &= 0.36 \text{ mol} \end{aligned}$$

4. How N_2 and CO have same number of electrons, protons and neutrons?**Ans:**

Number of electrons in C = 6

Number of electrons in O = 8

Total number of electrons = $6 + 8 = 14$

Number of protons in C = 6

Number of protons in O = 8

Total number of protons = $6 + 8 = 14$

Number of neutrons in C = 6

Number of neutrons in O = 8
 Total number of neutrons = 6 + 8 = 14

Hence, N₂ and CO have same number of electrons, protons and neutrons

5. One mole of H₂O has 2 moles of bonds, 3 moles of atoms, 10 moles of electrons, and 28 moles of total fundamental particles present in it.

Ans: The formula of water is:



- i. Two moles of covalent bonds
- ii. Total three moles of atoms
- iii. 10 moles of electrons because 8 moles of electrons are contributed by one mole of oxygen and 2 moles of electrons are contributed by 2 moles of hydrogen.
- iv. Number of particles in one mole of oxygen = $8p + 8n + 8e = 24$ mole particles
 No. of particles in two moles of H atoms = 4 mole particles
 Total no. of particles = $24 + 4 = 28$ moles

6. One mole of H₂SO₄ should completely react with two moles of NaOH. How does Avogadro's number help to explain it?

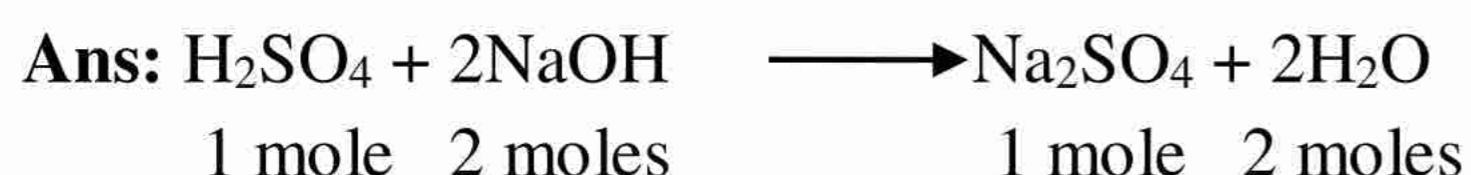

Apply Avogadro's number concept:

1 mole of H₂SO₄ generate H⁺ ions = $2 \times 6.02 \times 10^{23}$ H⁺ ions
 2 moles of NaOH generate OH⁻ ions = $2 \times 6.02 \times 10^{23}$ OH⁻ ions

It is clear from the above calculations that the number of H⁺ and OH⁻ ions formed are same although the number of moles of H₂SO₄ and NaOH are different. That is why 1 mole of H₂SO₄ reacts completely with 2 moles of NaOH.

7. Calculate the percentage of nitrogen in urea.

Ans: Molar mass of NH₂CONH₂ = $14 \times 2 + 12 + 16 + 4 = 60$ g/mol

%age of nitrogen = $28/60 \times 100 = 46.67\%$

8. How 4.9 g of H₂SO₄ when completely ionized in water have equal number of +ve and -ve charges but the number of positively charged ions are twice the number of negatively charged ions.

Ans:

Number of moles of $\text{H}_2\text{SO}_4 = 4.9/98 = 0.5$ mole

0.5 mole of H_2SO_4 yields 1 mole of H^+ ions and 0.5 mole of SO_4^{2-} ions as

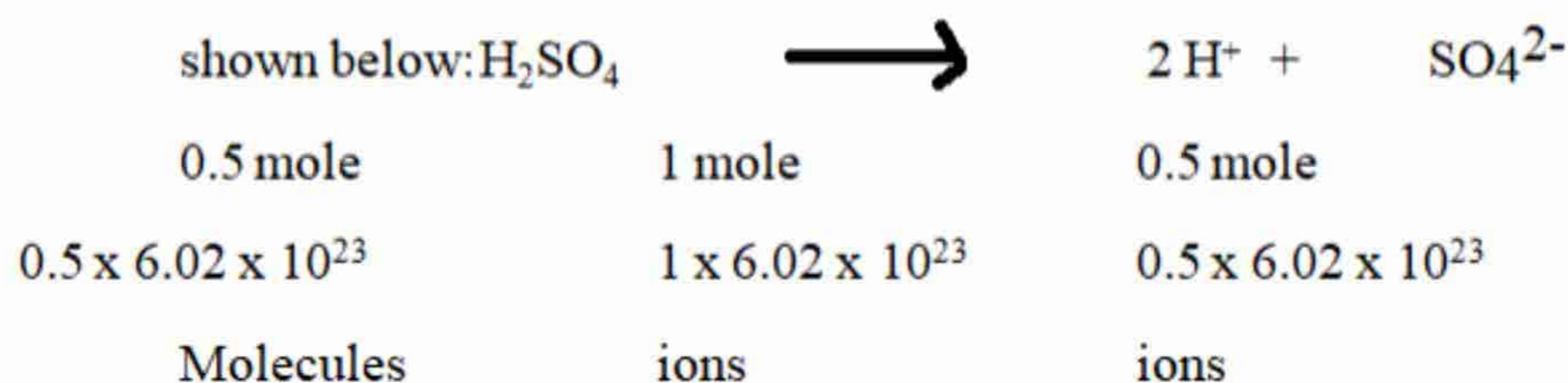

The relationship shows that total positive charges are equal to total negative charges because each SO_4^{2-} ion has -2 charge and two H^+ have also +2 charge. The above relationship shows that number of positive ions is twice as compared to negative ions.

9. How one mg of K_2CrO_4 has thrice the number of ions than the number of formula units when ionized?

Ans:



Mass of $\text{K}_2\text{CrO}_4 = 1 \text{ mg} = 0.001 \text{ g}$
Molar mass of $\text{K}_2\text{CrO}_4 = 194 \text{ g/mol}$

$$\begin{aligned} \text{Number of formula units of } \text{K}_2\text{CrO}_4 &= \text{Mass/Molar mass} \times N_A \\ &= \frac{0.001 \times 6.02 \times 10^{23}}{194} \\ &= 3.103 \times 10^{18} \end{aligned}$$

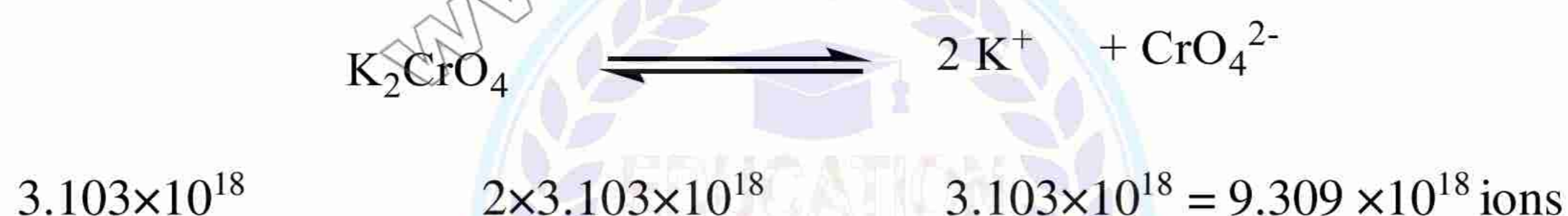

Hence, it is justified that the total number of ions (9.309×10^{18}) are thrice the number of formula units (3.103×10^{18})

10. Calculate the mass in Kg of 2.6×10^{20} molecules of SO_2 .

Ans:

6.02×10^{23} molecules of SO_2 have mass = 64 g

One molecule of SO_2 has mass = 64 g

6.02×10^{23} molecules of SO_2 have mass = 64/ 6.02×10^{23}

2.6×10^{20} molecules of SO_2 have mass = $64 \times 2.6 \times 10^{20} / 6.02 \times 10^{23} = 0.431 \times 64 \times 10^{-3}$

$$= 2.7 \times 10^{-2} \times 10^{-3} \text{ kg}$$

$$= 2.7 \times 10^{-5} \text{ kg}$$

Chapter 2

Experimental Techniques in Chemistry



Q. Define analytical chemistry.

Analytical chemistry is the science of chemical characterization.

Q. Difference between qualitative analysis and quantitative analysis.

Qualitative analysis gives identification of the elements and quantitative analysis tells about relative amounts of the elements. For example, detection of C, H, O in glucose is qualitative and their exact number $C_6H_{12}O_6$ is quantitative analysis.

Q. Mention steps for analysis.

- i. Obtaining sample ii. Separate constituents iii. Calculation of results iv. Conclusion

Filtration

Q. Define filtration.

The process of filtration is used to **separate insoluble particles from liquids.**

Q. Tell about Gooch crucible and sintered glass crucible.

- **Gooch crucible**
 - i. Porcelain made
 - ii. Filter paper fitted on perforated base
 - iii. Conc. HCl and $KMnO_4$ filtered by asbestos mat as they burn filter paper**
 - iv. Suction pump for quick filtration
- **Sintered glass crucible**
 - i. Glass made
 - ii. No filter paper needed
 - iii. Suction pump for quick filtration

Q. How fluted filter paper increases rate of filtration?

Fluted filter paper has many folds to increase surface area for speedy filtration.

Crystallization

Q. Define crystallization.

Crystallization is the removal of a solid from solution by increasing its concentration above the saturation point in such a manner that the excess solid separates out in the form of crystals.

Q. What are the characteristics of a good solvent?

Characteristics of a good solvent

- i. Dissolve a large amount of the substance at its boiling point and less at room temperature
- ii. No reaction with solute
- iii. No crystallization of impurities with solute
- iv. Well-formed crystals
- v. Inexpensive
- vi. Safe and removable

Q. Mention steps of crystallization.

- i. Saturated solution ii. Filtration for removing impurities iii. Cooling of mother liquor
iv. Filtration to collect crystals v. Drying

Q. Which method is best for drying the crystals?

Vacuum desiccator is best to dry the crystals using **CaCl₂, silica gel or phosphorus pentoxide** as drying agents.

Q. How decolourization of undesirable colours is done?

Decolourization of undesirable colours is done by **boiling with animal charcoal**.

Q. What is the disadvantage of using filter paper for drying the crystals?

The thin fibers of filter paper stick to the crystals and make them impure.

Sublimation**Q. Define sublimation. Give examples.**

It is a process in which a solid, when heated, vaporizes directly without passing through the liquid phase and these vapours can be condensed to form the solid again. Examples, **ammonium chloride, iodine, naphthalene, benzoic acid**.

Q. How sublimation of crude product is done?

Crude substance taken in china dish. Funnel with filter paper inverted over it with cotton plug in opening of stem of funnel. Heated till sublimate separates and deposits on filter paper.

Solvent Extraction

Ether extraction is the most commonly used.

Q. State distribution law.

A solute distributes itself between two immiscible liquids in a constant ratio of concentration irrespective of the amount of solute added.

Q. Why repeated extractions are more effective in solvent extraction.

Repeated extractions using small portions of solvent are more efficient in terms of increasing percentage yield of a reaction.

Q. Mention process of solvent extraction/ether extraction.

- Ether is added in the water layer (aqueous phase) in separating funnel, shaken and allowed to stand. The two separate layers formed will be separated and evaporation of ether layer (organic phase) will give the organic compound.
- The ratio of the final concentrations in two phases tells about distribution coefficient (K).

$$K = \frac{[I_2(CCl_4)]}{[I_3^- (aq)]}$$
- **Iodine is purple in CCl₄ and brown in aqueous phase.**

Chromatography**Q. Define chromatography**

The word chromatography originates from the **Greek word "Khromatos" meaning colour writing**. It is used for the separation of a sample of mixture.

Q. Define stationary phase and mobile phase.

- **Stationary phase**
The stationary phase may be a solid or a liquid supported as a thin film on the surface of an inert solid.
- **Mobile phase**

The mobile phase flowing over the surface of the stationary phase may be a gas or a liquid.

Q. Define distribution coefficient according to chromatography.

Distribution coefficient

$$K = \frac{\text{Concentration of a component in the moving phase}}{\text{Concentration of that component in the stationary phase}}$$

Concentration of that component in the stationary phase

Q. Mention types of chromatography/ Difference between adsorption and partition chromatography.

Types based on phases

- **Adsorption chromatography:** In which the stationary phase is a solid. Substance leaves the mobile phase to become adsorbed on the surface of the solid phase. Example, column chromatography.
- **Partition chromatography:** In which the stationary phase is a liquid. The substances being separated are distributed throughout both the stationary and mobile phases. Example, paper chromatography.

Types based on working

- Ascending
- Descending
- Radial/circular

Q. What is locating agent?

In case of colourless spots a locating agent is sprayed. For example, ninhydrin for **amino acids** to get **blue spots**.

Q. What is R_f? Why it has no units?

$$R_f = \frac{\text{Distance travelled by a component from the original spot}}{\text{Distance travelled by solvent from the original spot}}$$

Distance travelled by solvent from the original spot

R_f is the ratio between two similar quantities so no units

Q. What is chromatogram?

Final dried filter paper with values of R_f is called **chromatogram**.

Q. What are the uses of chromatography?

- Separation, isolation and purification of the products.
- Qualitative and quantitative analysis.
- Purity determination.

Chapter 3

Gases

Units of Pressure

Q. Define one atmospheric pressure. Give units.

The pressure of air that can support 760 mmHg column at sea level, is called one atmosphere.

The **S.I. unit of pressure** is expressed in Nm^{-2}

One atm = 760 torr = 101325 Nm^{-2}

1 pascal = 1 Nm^{-2} .

760 torr = 101325 Pa = 101.325 kilopascals (kpa)

1 atm = 760 torr = 14.7 pounds inch^{-2} (used in engineering work)

The unit millibar is used by meteorologists.

Q. Define pressure.

Force per unit area is called pressure. **SI units** are Nm^{-2}

Gas Laws

Q. What are gas laws?

The **relationships between volume of a given amount of gas and the prevailing conditions of temperature and pressure** are called the gas laws.

Q. State Boyle's law.

The volume of a given mass of a gas at constant temperature is inversely proportional to the pressure applied to the gas.

$$PV = k \text{ (when T and n are constant)}$$

Q. State Charles' law.

The **volume** of the given mass of a gas **is directly proportional to the absolute temperature** when the pressure is kept constant.

$$V/T = k$$

Graphical Explanation of Boyle's law

Q. Define isotherms.

Isotherms are the **graphs between pressure and volume** by keeping the **temperature constant**.

Q. What happens to the position of isotherm at high temperature?

At high temperature the isotherm moves away from the axis.

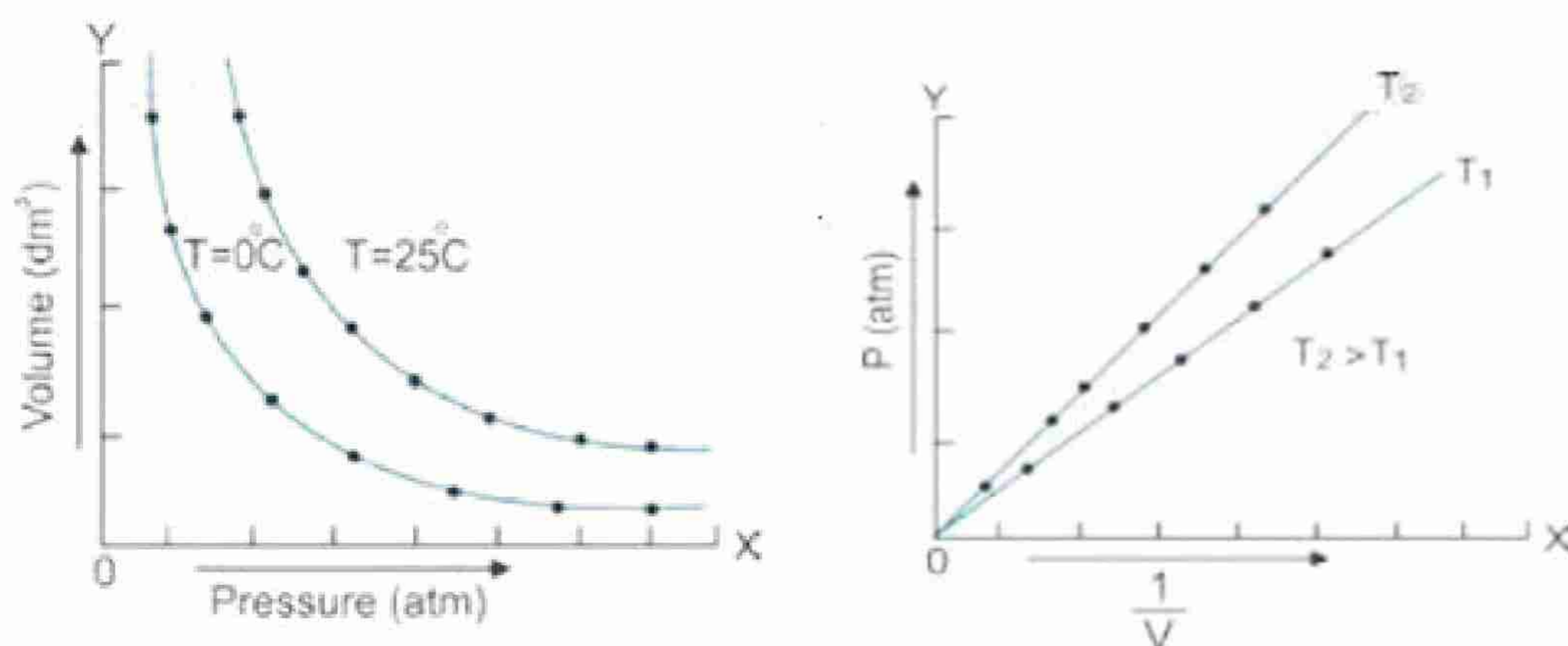

Q. The product of PV versus P is a straight line parallel to the pressure axis. Justify.

PV = k which is according to Boyle's law. So the law is justified.

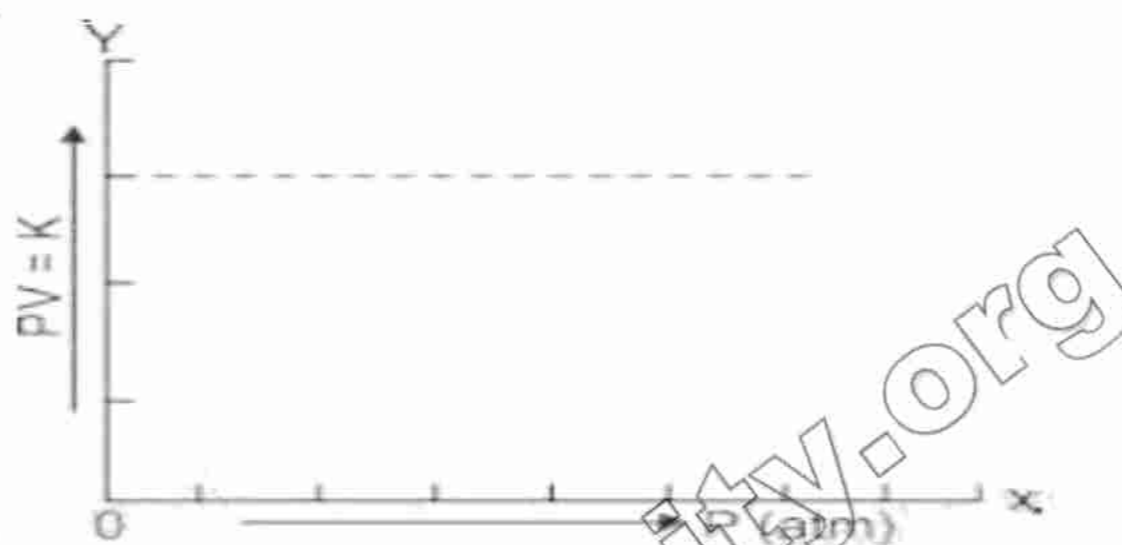

Derivation of Absolute Zero

Q. What is absolute zero? What happens to real gases while approaching it?

It is the lowest possible temperature which a gas would attain while remaining in the gaseous state. Its value is -273.16 °C or 0 K. It is a **hypothetical and unattainable temperature**. In fact all gases especially **real gases are converted to liquid** before reaching this temperature.

Q. Throw some light on the factor 1/273 in Charles' law. OR Give quantitative definition of Charles' law.

At constant pressure, the volume of the given mass of a gas increases or decreases by 1/273 of its original volume at 0 °C for every 1 °C rise or fall in temperature respectively.

$$V_t = V_0 \left(1 + \frac{t}{273}\right) \dots \dots \dots (3)$$

Where V_t = volume of gas at temperature T

V_0 = Volume of gas at 0°C

t = Temperature on centigrade or celsius scale

Q. Why Celsius scale does not justify Charles' law? AND Which scale justifies Charles' law?

The increase in temperature from 10 °C to 100 °C, increases the volume from 566 cm³ to 746 cm³. Applying Charles's law:

$$\frac{V_1}{T_1} = \frac{V_2}{T_2}$$

$$\frac{566}{10} \neq \frac{746}{100}$$

Charles' law is obeyed when the temperature is taken on the Kelvin scale. For example, at 283 K (10 °C) the volume is 566 cm³, while at 373 K (100 °C) the volume is 746 cm³. According to Charles's law:

$$\frac{V_1}{T_1} = \frac{V_2}{T_2} = K$$

$$\frac{566}{283} = \frac{746}{373} = 2 = K$$

Q. Tell about the scales of thermometry.

Celsius scale	Fahrenheit scale	Kelvin scale
M.P or F.P= 0 °C, B.P= 100 °C	M.P or F.P= 32 °F, B.P= 212 °F	M.P or F.P= 273 K, B.P= 373 K
Divided into 100 equal parts	Divided into 180 equal parts	Divided into 100 equal parts

Q. Write formulas to interconvert scales of temperature.

$$K = ^\circ C + 273.16$$

$$^\circ C = \frac{5}{9}[^\circ F - 32]$$

$$^\circ F = \frac{9}{5}(^\circ C) + 32$$

General Gas Equation

$$PV = nRT$$

Q. What is the physical meaning of R?

If we have one mole of an ideal gas at 273.16 K and one atmospheric pressure and its temperature is increased by 1 K, then it will absorb 0.0821 dm³-atm of energy.

$\text{dm}^3\text{-atm}$ is the unit of energy.

Q. Calculate the units of ideal gas constant (R) in SI units.

$$1 \text{ atm} = 760 \text{ torr} = 101\,325 \text{ Nm}^{-2}$$

$$1 \text{ m}^3 = 1000 \text{ dm}^3$$

$$n = 1 \text{ mole}$$

$$T = 273.16 \text{ K}$$

$$P = 1 \text{ atm} = 101325 \text{ Nm}^{-2}$$

$$V = 22.414 \text{ dm}^3 = 0.022414 \text{ m}^3$$

Putting their values, alongwith units.

$$R = \frac{PV}{nT} = \frac{101325 \text{ N m}^{-2} \times 0.02241 \text{ m}^3}{1 \text{ mol} \times 273.16 \text{ K}}$$

$$R = 8.3143 \text{ Nm K}^{-1} \text{ mol}^{-1} = 8.3143 \text{ J K}^{-1} \text{ mol}^{-1} \text{ (1 Nm = 1J)}$$

Since $1 \text{ cal.} = 4.18 \text{ J}$

$$\text{so } R = \frac{8.3143}{4.18} = 1.989 \text{ cal K}^{-1} \text{ mol}^{-1}$$

Q. Calculate the units of ideal gas constant (R) in S.T.P.

$$R = \frac{1 \text{ atm} \times 22.414 \text{ dm}^3}{1 \text{ mole} \times 273.16 \text{ K}}$$

$$R = 0.0821 \text{ dm}^3 \text{ atm K}^{-1} \text{ mol}^{-1}$$

Density of an Ideal Gas

Q. How density of an ideal gas is calculated?

$$n = \frac{m}{M}$$

$$PV = \frac{m}{M} RT$$

$$PM = \frac{m}{V} RT$$

$$PM = d RT \quad \left(d = \frac{m}{V}\right)$$

$$d = \frac{PM}{RT}$$

Q. Derive expression for the molecular mass of the gas using general gas equation.

$$PV = nRT$$

$$PV = \frac{m}{M} RT$$

$$M = \frac{mRT}{PV}$$

Avogadro's Law

Q. State Avogadro's law.

Equal volumes of all the ideal gases at the same temperature and pressure contain equal number of molecules.

$$V \propto n$$

$$V = kn$$

Dalton's Law of Partial Pressures



Q. State Dalton's law of partial pressures.

The total pressure exerted by a mixture of non-reacting gases is equal to the sum of their individual partial pressures.

$$P_t = p_1 + p_2 + p_3$$

Q. How Dalton's law of partial pressures is applicable to the collection of gases under water?

Some gases are collected over water in the laboratory. The gas during collection gathers water vapours and becomes moist. The pressure exerted by this moist gas is, therefore, the sum of the partial pressures of the dry gas and that of water vapours.

$$P_{\text{moist}} = P_{\text{dry}} + P_{\text{w.vap}}$$

$$P_{\text{moist}} = p_{\text{dry}} + \text{aqueous tension}$$

$$p_{\text{dry}} = P_{\text{moist}} - \text{aqueous tension}$$

Q. How Dalton's law finds application in breathing process?

The process of respiration depends upon the difference in partial pressures. When animals inhale air then oxygen moves into lungs as the **partial pressure of oxygen in the air is 159 torr**, while the **partial pressure of oxygen in the lungs is 116 torr**. CO₂ produced during respiration moves out in the opposite direction, as its partial pressure is more in the lungs than that in air.

Q. Why pilots feel uncomfortable breathing at high altitudes?

At higher altitudes, the pilots feel uncomfortable breathing because the partial pressure of oxygen in the un-pressurized cabin is low, as compared to 159 torr, where one feels comfortable breathing.

Q. Why deep sea divers take oxygen mixed with an inert gas?

Deep sea divers take oxygen mixed with an inert gas say He and adjust the partial pressure of oxygen according to the requirement. In sea, **after every 100 feet, the diver experiences 3 atm pressure**, so normal air cannot be breathed. The pressure of N₂ increases in depth of sea and it diffuses in the blood.

Q. Prove $p_A = P_t \cdot x_A$

$$P_t V = n_t RT \quad \text{..... (equation for the mixture of gases)}$$

$$p_A V = n_A RT \quad \text{..... (equation for gas A)}$$

$$p_B V = n_B RT \quad \text{..... (equation for gas B)}$$

Divide the first two equations

$$\frac{p_A V}{P_t V} = \frac{n_A RT}{n_t RT}$$

$$\frac{p_A}{P_t} = \frac{n_A}{n_t}$$

$$p_A = \frac{n_A}{n_t} P_t$$

$$p_A = x_A P_t \quad (x_A \text{ is mole fraction of gas A})$$

Kinetic Molecular Theory

Q. Give four fundamental postulates of KMT.

1. Every gas consists of a large number of very small particles called molecules. Gases like He, Ne, Ar have mono-atomic molecules.

- The molecules of a gas move haphazardly, colliding among themselves and with the walls of the container and change their directions.
- The pressure exerted by a gas is due to the collisions of its molecules with the walls of a container. The collisions among the molecules are perfectly elastic.
- The molecules of a gas are widely separated from one another and there are sufficient empty spaces among them.

Q. Mention faulty postulates of KMT.

- The molecules of a gas have **no forces of attraction** for each other.
- The **actual volume of molecules of a gas is negligible** as compared to the volume of the vessel.

Boyle's Law, Charles' Law, Avogadro's Law, Graham's Law According to KMT

Boyle's Law

$$\frac{1}{2} mN\bar{c}^2 \propto T$$

$$\frac{1}{2} mN\bar{c}^2 = kT$$

$$PV = \frac{1}{3} mN\bar{c}^2$$

Multiplying and dividing by 2 on right hand side

$$PV = \frac{2}{3} \left(\frac{1}{2} mN\bar{c}^2 \right)$$

$$PV = \frac{2}{3} kT$$

If the temperature (T) is constant then constant be k'.

So, $PV = k'$ (which is Boyle's law)

Hence at constant temperature and number of moles, the product PV is a constant quantity.

Charles's Law

Or

$$PV = \frac{2}{3} kT$$

$$V = \frac{2}{3} \frac{kT}{P} = \left(\frac{2k}{3P}\right) T$$

At constant pressure,

Therefore,

$$\frac{2k}{3P} = k'' \text{ (a new constant)}$$

or

$$V = k'' T$$

$$\frac{V}{T} = k'' \text{ (which is Charles's law)}$$

Avogadro's Law

$$PV = \frac{1}{3} m_1 N_1 \overline{c_1^2} \text{ for gas(1)}$$

$$PV = \frac{1}{3} m_2 N_2 \overline{c_2^2} \text{ for gas(2)}$$

$$\text{Equalizing } \frac{1}{3} m_1 N_1 \overline{c_1^2} = \frac{1}{3} m_2 N_2 \overline{c_2^2}$$

$$\text{Hence, } m_1 N_1 \overline{c_1^2} = m_2 N_2 \overline{c_2^2}$$

$$\frac{1}{2} m_1 \overline{c_1^2} = \frac{1}{2} m_2 \overline{c_2^2}$$

$$m_1 \overline{c_1^2} = m_2 \overline{c_2^2}$$

$$N_1 = N_2$$

Graham's Law of Diffusion

$$PV = \frac{1}{3} mN\bar{c}^2$$

$$PV = \frac{1}{3} mN_A\bar{c}^2$$

$$PV = \frac{1}{3} M\bar{c}^2 \quad (M = mN_A)$$

$$\bar{c}^2 = \frac{3PV}{M}$$

$$\sqrt{\bar{c}^2} = \sqrt{\frac{3PV}{M}}$$

$$\sqrt{\bar{c}^2} = \sqrt{\frac{3P}{M/V}} = \sqrt{\frac{3P}{d}} \quad \left(\frac{M}{V} = d\right)$$

SO

$$\sqrt{\bar{c}^2} \propto r$$

$$r \propto \sqrt{\frac{3P}{d}}$$

At constant pressure

$$r \propto \sqrt{\frac{1}{d}}$$

Diffusion and Effusion

Spontaneous movement of molecules from high to low concentration is diffusion.

Escape of molecules through a small opening from high to low concentration is effusion.

Q. State Graham's law of diffusion.

The rate of diffusion or effusion of a gas is inversely proportional to the square root of its density at constant temperature and pressure.

$$\frac{r_1}{r_2} = \frac{\sqrt{d_2}}{\sqrt{d_1}}$$

$$\frac{r_1}{r_2} = \frac{\sqrt{M_2}}{\sqrt{M_1}}$$

Q. Why ammonia diffuses more rapidly than HCl? OR Why lighter gases diffuse more rapidly than heavier ones?

The molar mass of NH_3 is 17 g/mol and that of HCl is 36.5 g/mol. So NH_3 being light diffuses more rapidly than HCl.

$$\frac{r_1}{r_2} = \sqrt{\frac{M_2}{M_1}}$$

Liquefaction of Gases



Q. Define critical temperature (T_c) and critical pressure (P_c).

The **highest temperature at which a substance can exist as a liquid**, is called its critical temperature (T_c).

The **pressure which is required to bring about liquefaction at critical temperature (T_c)** is called critical pressure (P_c).

Volume of 1 mole of gas at critical temperature and pressure is called critical volume V_c .

Q. State Joule-Thomson effect.

When a highly compressed gas is allowed to expand into the region of low pressure it gets cooled.

Q. Hydrogen and helium are ideal at room temperature but SO_2 and Cl_2 are non-ideal. Justify.

In helium and hydrogen, already there are weaker Van der Waal's forces because these are non-polar and their particle size is very small so they behave ideally at room temperature. On the other hand, SO_2 and Cl_2 are either polar (SO_2) or having bigger molecules so there are strong intermolecular forces in them which make them non-ideal at room temperature.

Q. When do gases behave ideally and non-ideally.

(i) Gases are **ideal at low pressure** and non-ideal at high pressure.

(ii) Gases are **ideal at high temperature** and non-ideal at low temperature.

Q. SO₂ is comparatively non-ideal at 273K but behave ideally at 373K.

At 273 K attractive forces are there in SO₂ gas so it behaves ideally, whereas, at 373 K attractive forces are broken and it behaves non-ideally.

Q. Water vapors do not behave ideally at 273K. Give reason.

At 273 K attractive forces are present among water vapours so they start behaving non-ideally.

Q. Pressure of ammonia gas at given conditions is less as calculated by Vander Waal equation than that calculated by general gas equation. Why?

Van der Waal's equation tells about intermolecular forces which decrease the observed pressure of a gas. So, pressure of NH₃ gas calculated with this equation shall be mathematically lesser as compared to the value of pressure calculated from ideal gas equation.

$$PV = nRT$$

Vander Waal's equation is as follows:

$$(P + n^2a/V^2)(V - nb) = nRT$$

Q. Derive the units for van der Waal's constants 'a' and 'b'. Give their physical significance.

'a' is the attraction per unit volume and is called co-efficient of attraction for one mole of a gas.

'b' is effective volume or excluded or incompressible volume per mole.

Units of a

$$a = \frac{P'V^2}{n^2}$$

$$a = \frac{\text{atm} \times (\text{dm}^3)^2}{(\text{mol})^2}$$

$$a = \text{atm dm}^6 \text{ mol}^{-2}$$

In S.I. units, pressure is in Nm^{-2} and volume in m^3

$$a = \frac{\text{Nm}^{-2} \times (\text{m}^3)^2}{(\text{mol})^2}$$

$$a = \text{Nm}^{-4} \text{ mol}^{-2}$$

Units of b

$\text{dm}^3 \text{ mol}^{-1}$ or $\text{m}^3 \text{ mol}^{-1}$

Plasma

Q. Define plasma.

Ionized gas mixture, consisting of ions, electrons and neutral atoms is called plasma.

Q. What is the difference between natural and artificial plasma.

Artificial plasma can be created by **ionization of a gas**. Plasma at low temperatures is hard to maintain because **outside a vacuum low temperature plasma reacts rapidly** with any molecule it encounters.

Natural plasma exists **naturally**. It exists only at **very high temperatures, or low temperature vacuums**. Natural plasma **does not breakdown or react rapidly**. It is **extremely hot (over 20,000°C minimum)**.

Q. What are the characteristics of plasma?

1. The **motion of the particles** in the plasma **generates fields and electric currents** from within plasma due to density of the charged particles.

2. Plasma is **macroscopically neutral**. In measurable quantities the number of electrons and ions are equal.

Q. Give any two applications of plasma.

1. A **fluorescent light bulb** has a long tube with gas. When the light is turned on, electricity flows through the tube and charges up the gas, hence, creating glowing plasma inside the bulb.

2. **Neon signs** are glass tubes filled with gas. When they are turned on then the electricity flows through the tube. The plasma glows with a special colour depending on what kind of gas is inside.

Selective Numericals for Short Questions**Q. Calculate the density of methane at STP.**

$$\begin{aligned} d &= PM/RT \\ &= 1 \times 16 / 0.0821 \times 273 \\ &= 0.7138 \text{ g dm}^{-3} \end{aligned}$$

Q. Calculate number of molecules and number of atoms in 20 cm³ of CH₄ at 0 °C and 700mm of Hg.

$$\begin{aligned} PV &= nRT \\ n &= PV/RT \\ n &= 0.921 \times 20 / 0.082 \times 273 \\ n &= 18.42 / 22.386 \\ n &= 0.823 \text{ mol} \\ \text{No. of molecules of CH}_4 &= 0.823 \times 6.02 \times 10^{23} = 4.95 \times 10^{23} \text{ molecules} \\ \text{No. of atoms} &= 5 \times 4.95 \times 10^{23} = 24.77 \times 10^{23} = 2.477 \times 10^{24} \text{ atoms} \end{aligned}$$

Numericals for Long Questions

Important Numericals are:

Example 3, Example 4, Example 5, Example 7, Example 8

Chapter 4

Liquids and Solids

Intermolecular Forces

Following are the intermolecular forces:

1. Dipole-dipole forces
2. Ion-dipole forces
3. Dipole-induced dipole forces
4. Instantaneous dipole-induced dipole forces

Q. What are dipole-dipole forces of attraction? Explain with examples.

When the positive end of one molecule attracts the negative end of the other molecule then these electrostatic forces of attraction are called dipole-dipole forces. For example, dipole-dipole forces are present in HCl and CHCl_3

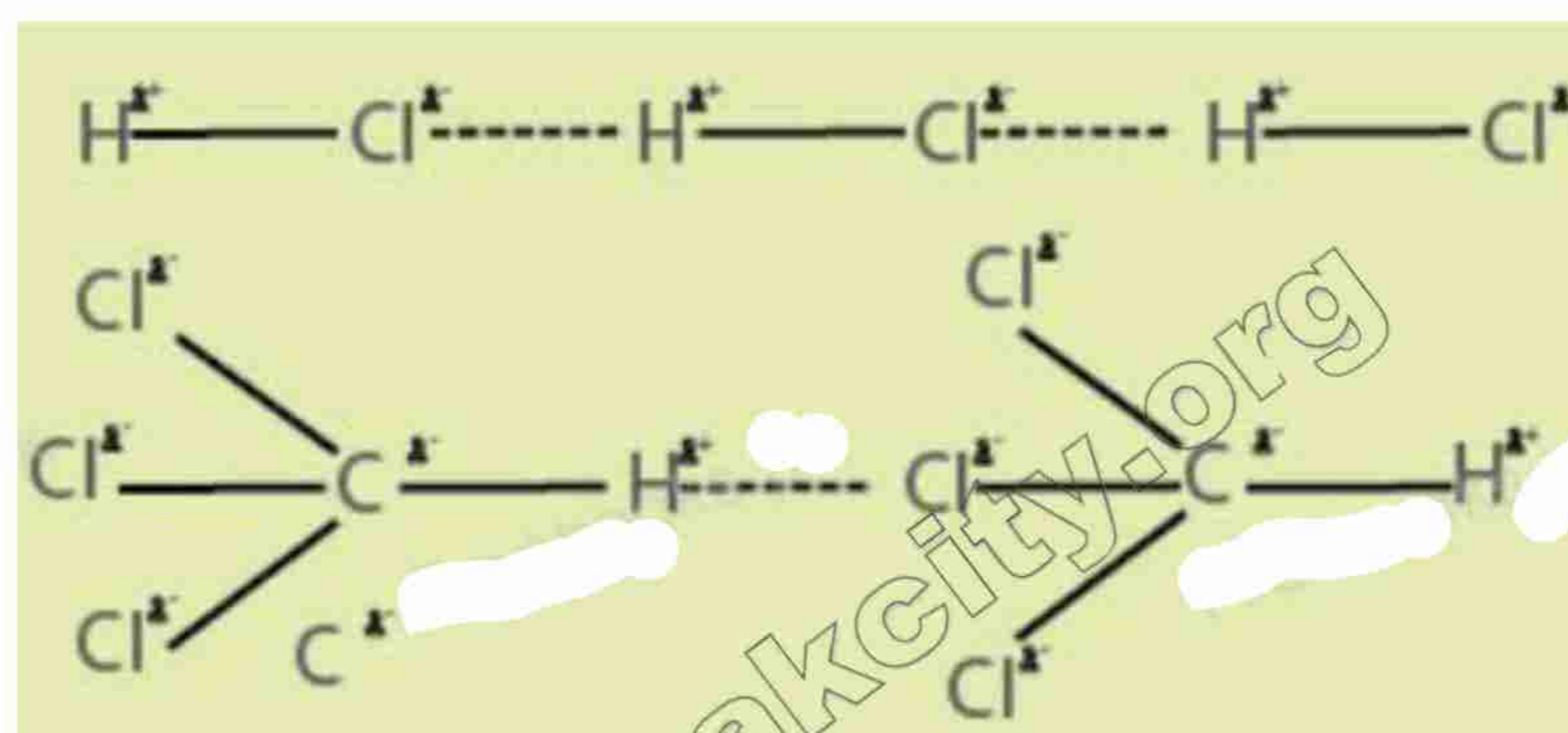

Q. What are dipole-induced dipole forces or Debye forces? Give examples.

When the positive end of the polar molecule attracts the mobile electrons of the nearby non-polar molecule then polarity is induced in non-polar molecule, and both molecules become dipoles. These forces are called dipole-induced dipole forces or Debye forces.

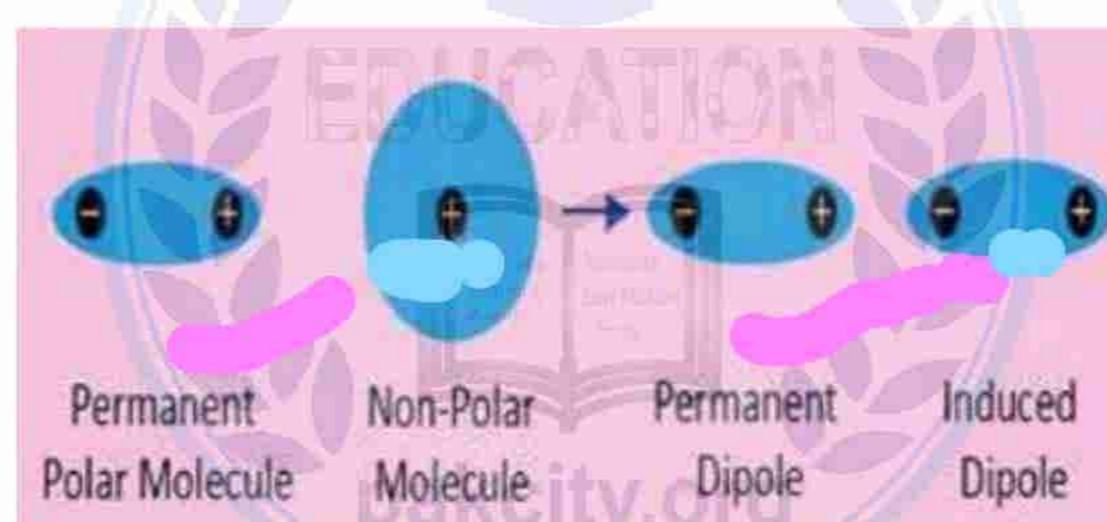

REMEMBER ALL THE MENTIONED POINTS OF LONDON FORCES FOR LONG QUESTION

Q. What are instantaneous dipole-induced dipole forces or London dispersion forces?

The momentary force of attraction created between instantaneous dipole and the induced dipole is called instantaneous dipole-induced dipole interaction or London force.

London forces significant for non-polar molecules like Cl_2 , H_2 and noble gases (helium, neon, etc.)

Q. Mention the factors on which London dispersion forces depend.

London dispersion forces depend on the following factors:

1. Atomic number
2. Size of atom/size of electronic cloud
3. Number of atoms in a molecule
4. Polarizability

Q. Define polarizability. Give its relation with London dispersion forces. AND Why boiling point of halogens increase down the group?

Polarizability is the quantitative measurement of the extent to which the electronic cloud can be polarized or distorted. **Strength of London dispersion forces increases as polarizability increases.**

The boiling points are increased down the group VII-A due to increased polarizability. Fluorine is a gas and boils at $-188.1\text{ }^{\circ}\text{C}$ while iodine is a solid at room temperature which boils at $+184.4\text{ }^{\circ}\text{C}$.

Q. How the number of atoms in a molecule affect London forces?

Greater the number of atoms in a molecule, greater is its polarizability. Compare the length of the chain for C_2H_6 and C_6H_{14} . They have the boiling points $-88.6\text{ }^{\circ}\text{C}$ and $68.7\text{ }^{\circ}\text{C}$, respectively. Longer molecules have more places along its length where they can be attracted to other molecules.

REMEMBER ALL THE MENTIONED POINTS OF HYDROGEN BONDING FOR LONG QUESTION

Q. Define hydrogen bonding.

The electrostatic force of attraction between a highly electronegative atom and partial positively charged hydrogen atom is called hydrogen bonding. For example, hydrogen bonding is present in water.

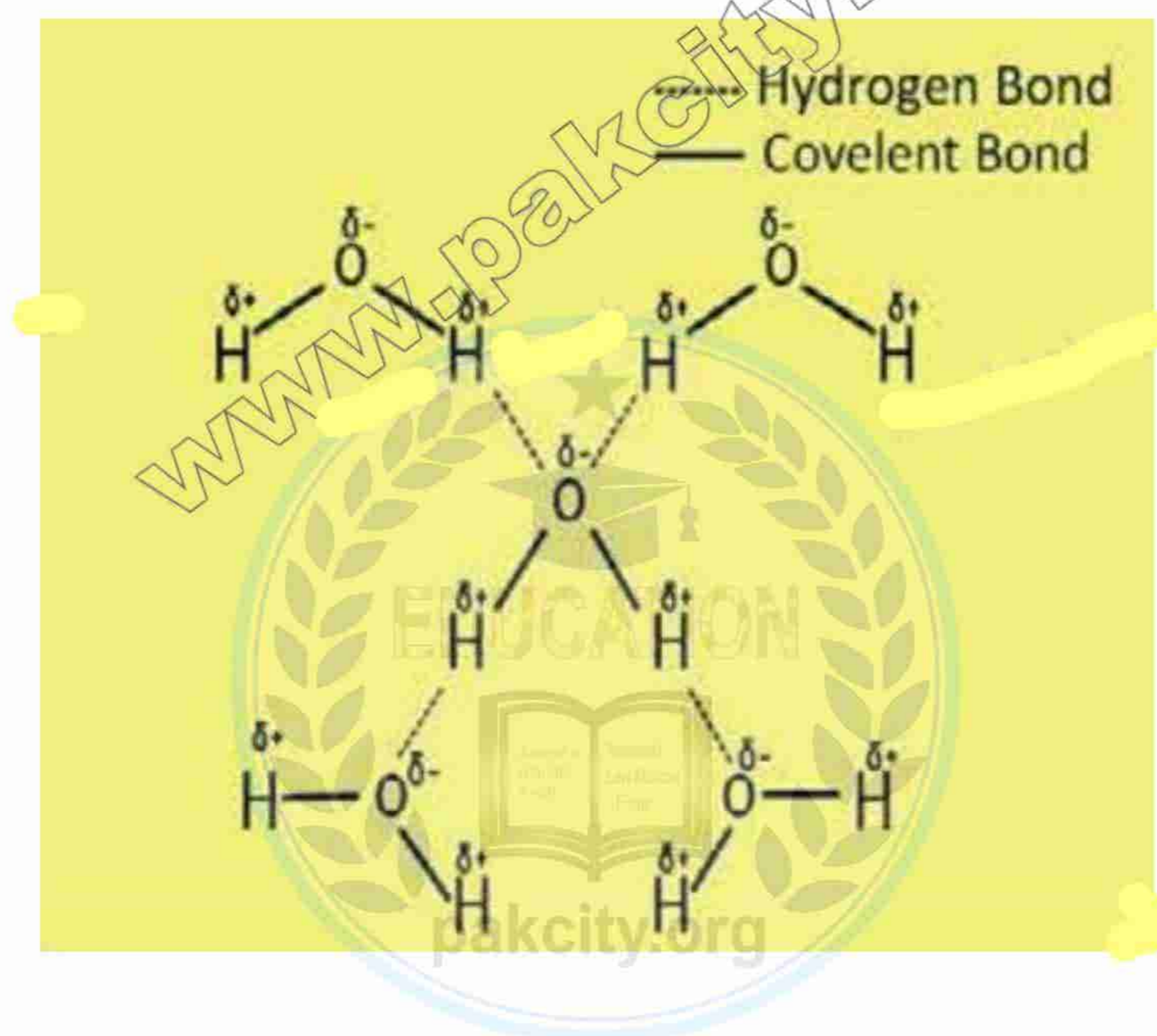

MUST KNOW

The electronegative atoms in H-bond: **fluorine, oxygen, nitrogen and rarely chlorine.**

Hydrogen bond is twenty times less strong than a covalent bond.

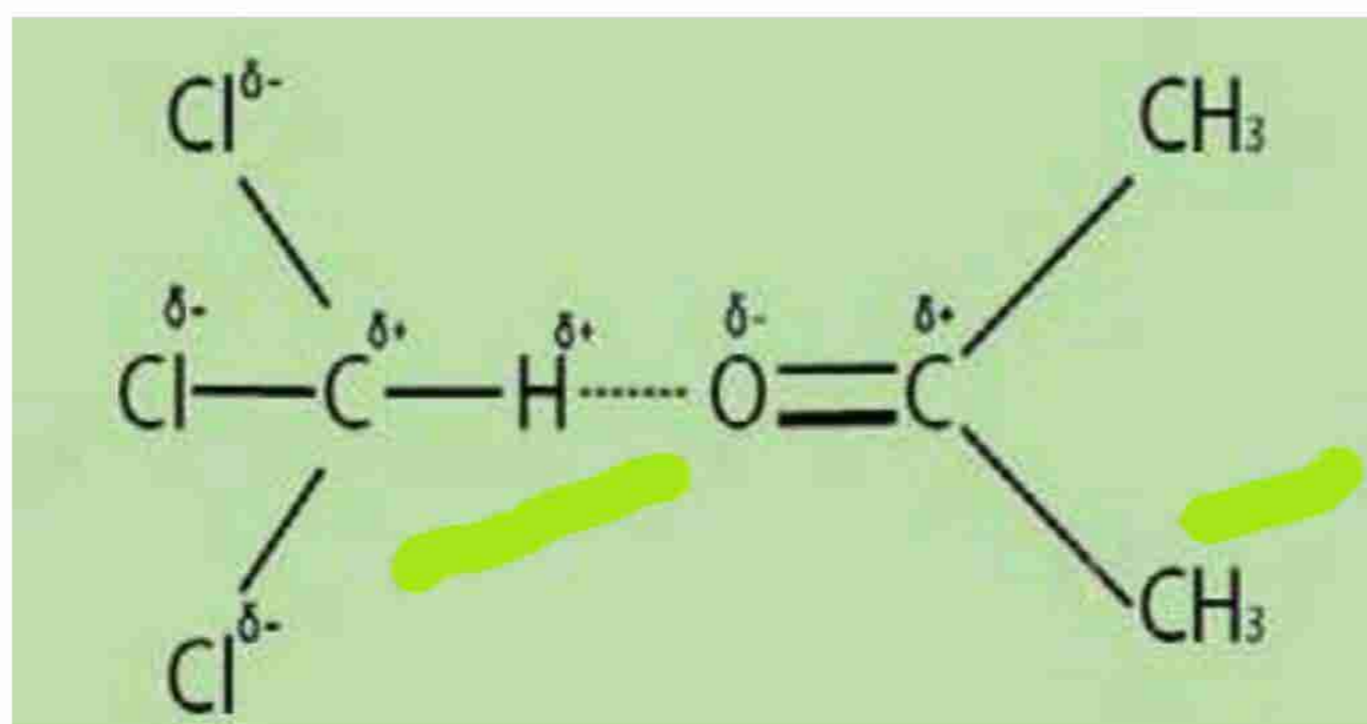

Between CHCl_3 and HCl

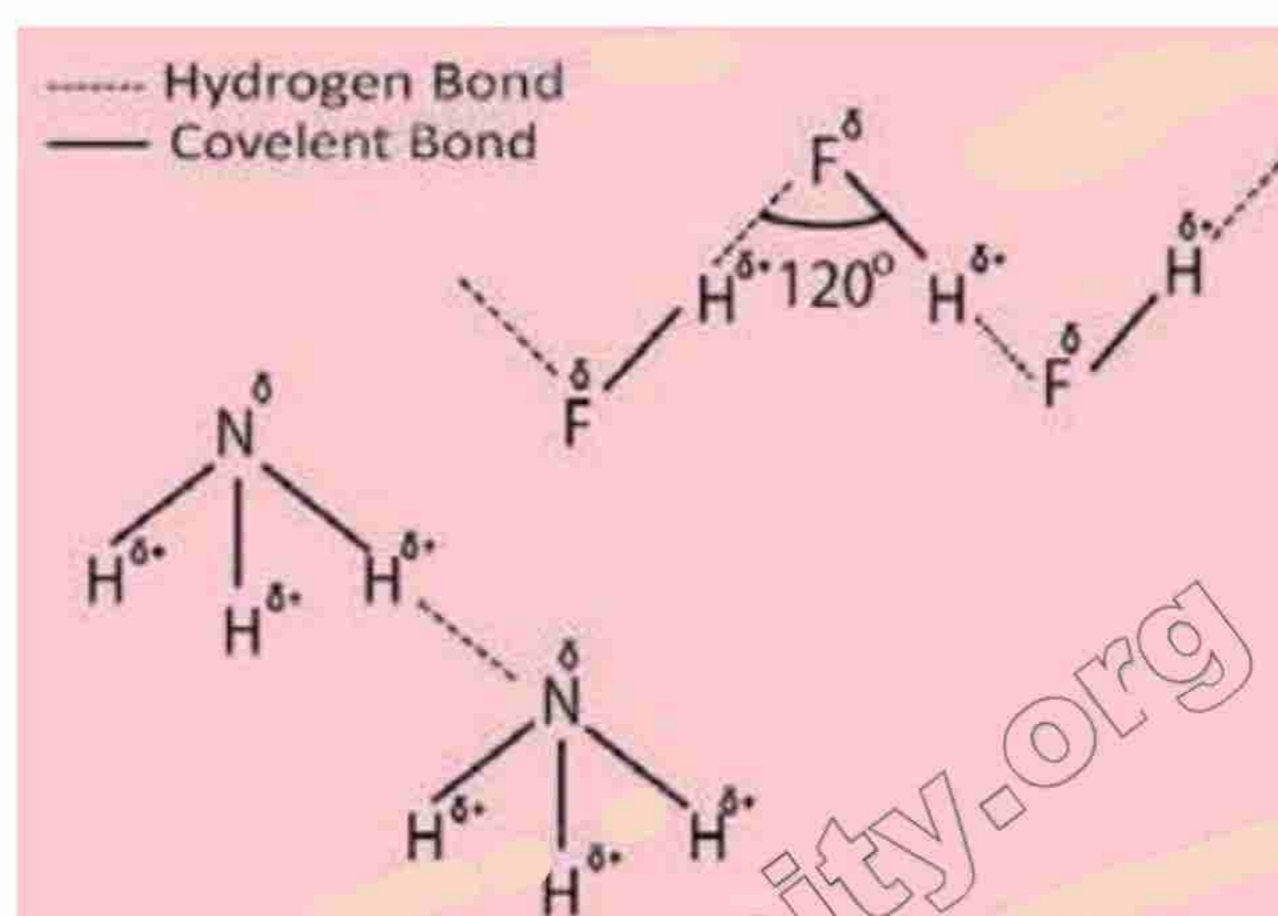

H-Bond in NH_3 and HF

Q. Why HF is a weak acid than HCl?

Low acidic strength of HF molecule as compared to HCl, HBr and HI is due to strong hydrogen bonding, because the partial positively charged hydrogen is entrapped between two highly electronegative atoms.

Properties and Applications of Compounds containing Hydrogen Bonding

(Learn for Short questions and Long Question)

1. Thermodynamic properties of Covalent Hydrides

- The hydrides of group IV-A have low boiling points as compared to hydrides of group VA, VI-A and VII-A because these elements are least electronegative.
- Oxygen is electronegative, hence, water is a liquid and has hydrogen bonding. There is no hydrogen bonding in H_2S and H_2Se as S and Se are not electronegative due to which they are gases.
- HF can make only one hydrogen bond. Water can form two hydrogen bonds per molecule.

2. Solubility of Hydrogen Bonded molecules

- Ethyl alcohol and small-sized carboxylic acids are soluble in water
- Hydrocarbons are not soluble in water as they do not form H-bond

3. Structure of Ice

- The molecules of water have tetrahedral structure.

- When the **temperature of water is decreased** and ice is formed then the **molecules become more regular** and this regularity extends throughout the whole structure and **empty spaces are created** in the structure.
- The structure of ice is just like that of a diamond and that is why when water freezes into ice it occupies **9% more space and its density is decreased with increase in volume.**

Q. Why fish survive in winter in frozen ponds?

The **water at the surface becomes less dense** in winters. This less dense water **below 4 °C** stays on the top of slightly warm water underneath. A stage reaches when it freezes. **This layer of ice insulates the water underneath for further heat loss.** Fish and plants survive under this blanket of ice for months.

4. Cleansing Action of Soaps and Detergents

The **polar parts of detergents are water soluble** and the **non-polar parts (alkyl or benzyl) remain outside water.**

5. Hydrogen Bonding in Biological Compounds and Food Materials

H-Bond in amino acids

- **Amino acids coil as a helix.** It may be **right handed or left handed.**
- In the case of right handed helix the groups like **>N H** and **> C = O** are **linked together by hydrogen bonds.**
- There are **27 amino acid units for each turn of the helix.**

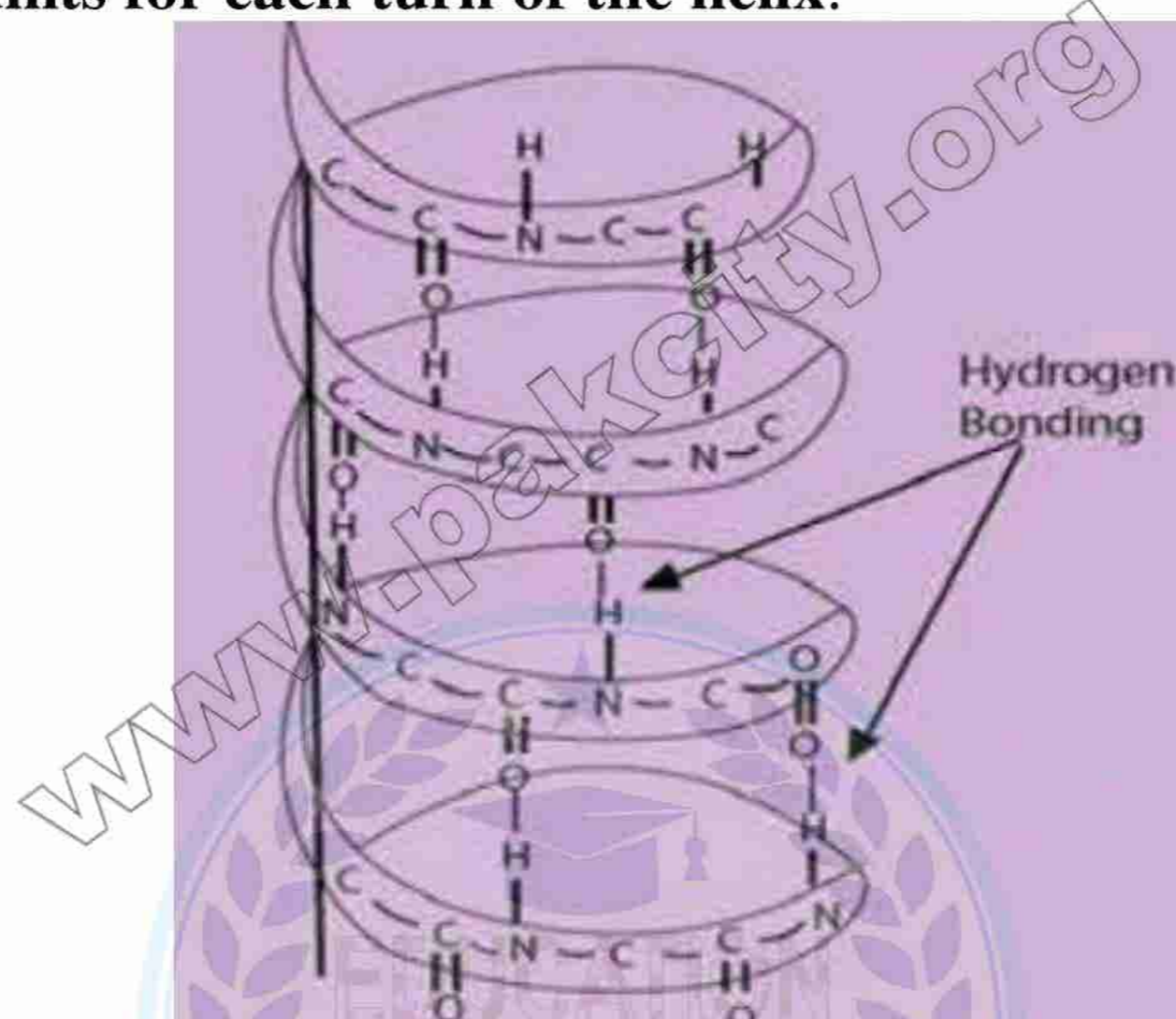

H-Bond in DNA

- Deoxyribonucleic acid (**DNA**) has **two spiral chains.**
- These are coiled about each other on a common axis to give a **double helix.**
- This is **18-20 Å in diameter.**
- They are linked together by **H-bonding between their sub-units.**

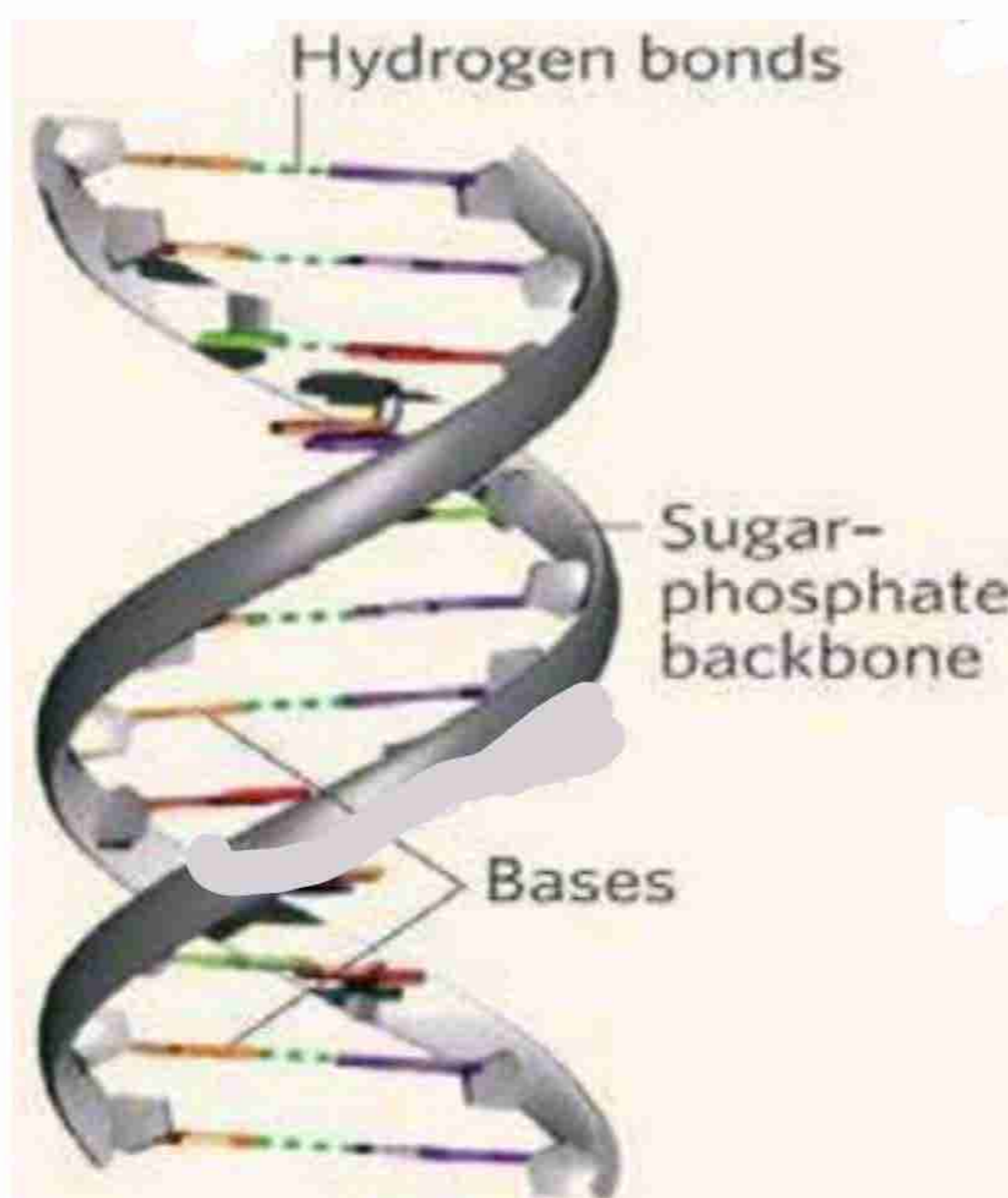

H-Bond in carbohydrates

Carbohydrates have -OH groups responsible for hydrogen bonding.

6. Hydrogen Bonding in Paints, Dyes and Textile Materials

- Adhesive action of paints and dyes is due to H-bond.
- Glue and honey are sticky substances due to H-bond.
- Cotton, silk or synthetic fibres have strength due to H-bond.

Evaporation

Spontaneous conversion of **liquid to vapours** is called evaporation.

Q. Why evaporation causes cooling?

Evaporation of a liquid causes cooling because high energy molecules escape and change into vapours during evaporation. So the temperature of liquid falls. Heat flows from surrounding to the liquid. This causes the temperature of surroundings to decrease.

Example, **one feels sense of cooling under fan after bath** as moisture present on skin evaporates taking away heat from body.

Q. Why earthenware vessels keep water cool?

Earthenware vessels are porous. Water molecules come out from the pores and evaporate by getting the required energy from other molecules of water. This evaporation process lowers the energy of water molecules left behind.

Q. Explain why evaporation takes place at all temperatures?

The molecules whose kinetic energies are greater than the average kinetic energies of the molecules, escape from the surface of the liquid. If temperature is increased, rate of evaporation also increases. Evaporation takes place at all temperatures and only the rate of evaporation differs with temperature change.

Vapour Pressure

Q. Define vapour pressure.

The vapour pressure of a liquid is a pressure exerted by the vapours of the liquid in equilibrium with the liquid at a given temperature.

(Learn for Long Question)

Manometric method (accurate method for vapour pressure)

- The liquid is taken in a flask placed in a thermostat.
- One end of the tube from the flask is connected to a manometer and the other end is connected to a vacuum pump.
- The liquid is frozen with the help of a freezing mixture.
- The air is removed from the surface of the liquid along with the vapours of that liquid.
- The frozen liquid is then melted to release any entrapped air.
- This process is repeated many times till almost all the air is removed.
- The liquid is warmed to that temperature at which its vapour pressure is to be determined.
- Difference in the heights of the columns of Hg determines the vapour pressure of the liquid.

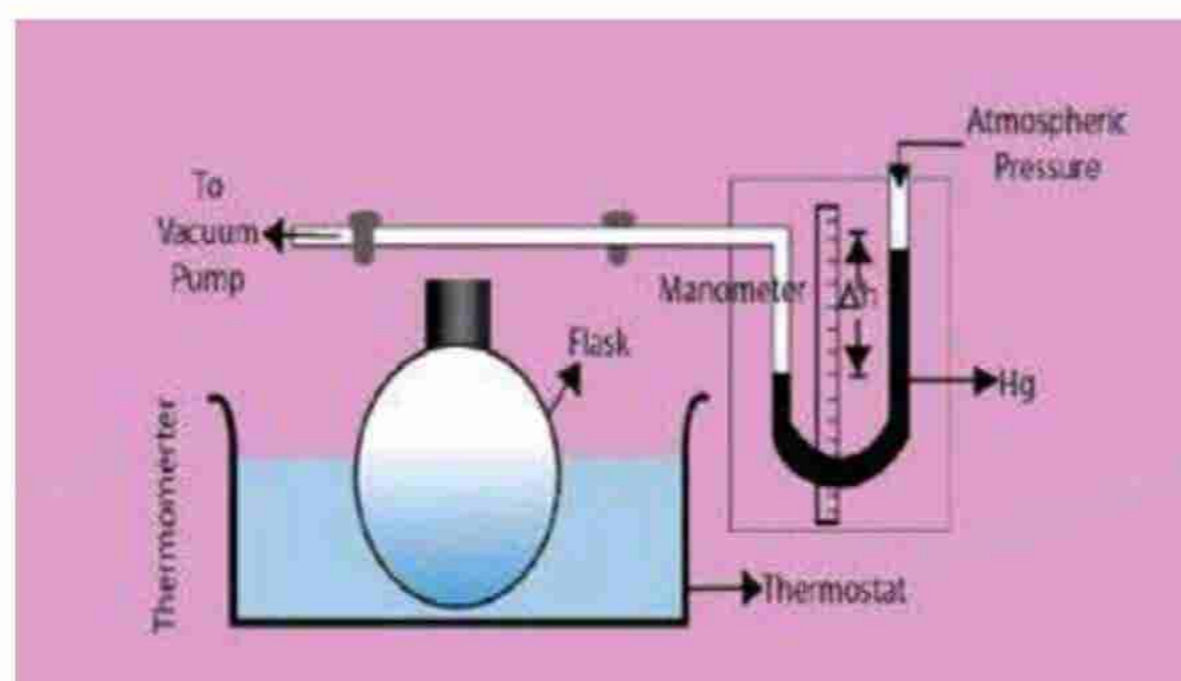

thermostat.
connected to a
connected to a
freezing mixture.
the liquid along
release any
almost all the air is

$$P = P_a + \Delta h$$

Boiling Point

When the vapour pressure becomes equal to atmospheric pressure

Boiling Point of Water

120 °C at 1489 torr and **25 °C at 23.7 torr.**

98 °C at Murree hills at **700 torr.**

Top of Mount Everest 69 °C at 323 torr.

Food cooks easily in a pressure cooker due to increased pressure and increased boiling point of water

Q. Why boiling needs a constant supply of heat?

At boiling point intermolecular forces break abruptly. Molecules get freedom, convert to bubbles and come out of the liquid. In order to continue this process, continuous heating is required for continuous boiling.

Q. Vacuum distillation can be used to avoid decomposition of sensitive liquids. How?

The decomposition of many compounds can be avoided by vacuum distillation. For example, **glycerin boils at 290 °C at 760 torr** but decomposes. **Under vacuum, the boiling temperature of glycerin decreases to 210 °C at 50 torr.** It is distilled at this temperature without decomposition.

Liquid Crystals



In 1888 by Frederick Reinitzer

Worked on Cholesteryl benzoate—Milky 145 °C---Clear liquid 179 °C

(Learn for Short Question and Long Question)

A liquid crystalline state exists between two temperatures i.e. melting temperature and clearing temperature.

Properties

1. Properties of liquids like surface tension, viscosity, fluidity etc.
2. Properties of solids like optical ones.
3. They are **anisotropic**

Structure of liquid crystals (Long rod-like molecules)

Depending upon the **nature of ordering**, liquid crystals can be divided into:

1. Nematic
2. Smectic
3. Cholesteric

Q. Mention any two uses of liquid crystals.

- i. In chromatographic separations, liquid crystals are used as solvents.
- ii. Oscillographic and TV displays also use liquid crystal screens.

Q. Give biological applications of liquid crystals.

Liquid crystalline substances are used to **locate the veins, arteries, infections and tumors**. The reason is that **these parts of the body are warmer than the surrounding tissues**. Specialists can use the techniques of **skin thermography to detect blockages in veins and arteries**. When a **layer of liquid crystal is painted** on the surface of the breast, **a tumor shows up as a hot area which is coloured blue**. This technique has been successful in the **early diagnosis of breast cancer**.

Solids

Those solids in which atoms, ions or molecules are arranged in a **definite three dimensional pattern** are called **crystalline solids**.

Amorphous substances are those whose constituent atoms, ions, or molecules **do not possess a regular orderly arrangement**.

The **crystalline parts of amorphous solids** are known as **crystallites**.

Properties of Crystalline Solids

(Learn for Short Question and Long Question)

1. Regular three dimensional structure.
2. High melting and boiling points.

Q. Cleavage of crystals is anisotropic behaviour. Why?

3. Whenever the **crystalline solids are broken** they do so **along definite planes**. These planes are called the **cleavage planes**. As it depends on direction so it is anisotropic.
4. Some of the crystals show **variation in physical properties depending upon the direction**. Such properties are called **anisotropic properties** and the **phenomenon** is referred to as **anisotropy**.

Q. Why graphite conducts electricity parallel to the layers?

Electrical conductivity of graphite is greater parallel to the layers than perpendicular to the layers. **Mobile electrons are in parallel direction**.

5. The repetition of faces, angles or edges when a crystal is rotated by 360° along its axis is called **symmetry**.

Q. How crystals change shape as habit is changed?

6. The shape of a crystal in which it usually grows is called **habit of a crystal**. For example, a cubic crystal of NaCl becomes needle like when 10% urea is present in its solution as an impurity.

7. **Isomorphism** is the phenomenon in which **two different substances** exist in the **same crystalline form**.

NaNO₃, KNO₃ Rhombohedral

Their **physical and chemical properties are quite different** from each other

8. **Polymorphism** is a phenomenon in which a **compound** exists in **more than one crystalline forms**.

AgNO₃ Rhombohedral, Orthorhombic

Polymorphs have same chemical properties, but, they differ in the physical properties

9. The existence of **an element in more than one crystalline forms** is known as **allotropy**.

Sulphur, S Rhombic, Monoclinic

10. **Transition temperature** is that temperature at which **two crystalline forms of the same substance can co-exist in equilibrium** with each other.

Transition temperature of **tin** is **13.2 °C** at which **Grey tin** having **cubic crystals** and **White tin** having **tetragonal crystals** co-exist.

Crystal Lattice

Q. Define crystal lattice.

A crystal lattice is an array of points representing atoms, ions or molecules of a crystal, arranged at different sites in three dimensional space.

Q. Define unit cell.

The smallest part of the crystal lattice has all the characteristic features of the entire crystal and is called a unit cell.

Q. Define cell dimensions or crystallographic elements.

The **three lengths of the unit cell a, b and c** and the **three angles α , β and γ** are called cell dimensions or crystallographic elements.

(Learn for Short Questions Especially)

Seven Crystal System (Bravais Lattices)

Sr. No	Crystal system	Axes	Angles	Examples
1.	cubic	$a = b = c$	$\alpha = \beta = \gamma = 90^\circ$	Fe, Cu, Ag, Au, NaCl, NaBr, Diamond
2.	Tetragonal	$a = b \neq c$	$\alpha = \beta = \gamma = 90^\circ$	Sn, SnO ₂ , MnO ₂ , NH ₄ Br
3.	Orthorhombic	$a \neq b \neq c$	$\alpha = \beta = \gamma = 90^\circ$	Iodoine, Rhombic, Sulphur, BaSO ₄ , K ₂ SO ₄
4.	Monoclinic	$a \neq b \neq c$	$\alpha = \gamma = 90^\circ, \beta \neq 90^\circ$	Sugar, Sulphur, Borax, NaSO ₄ .10H ₂ O
5.	Hexagonal	$a = b \neq c$	$\alpha = \beta = 90^\circ, \gamma = 120^\circ$	Graphite, ZnO, CdS, Ice, Zn, Cd
6.	Rhombohedral or Trigonal	$a = b = c$	$\alpha = \beta \neq \gamma = 90^\circ \text{ and } 120^\circ$	Bi, Al ₂ O ₃ , NaNO ₃ , KNO ₃
7.	Triclinic	$a \neq b \neq c$	$\alpha \neq \beta \neq \gamma \neq 90^\circ$	H ₃ BO ₃ , K ₂ Cr ₂ O ₇ , CuSO ₄ .5H ₂ O

Classification of Solids

(Learn for Short Questions and Long Questions)

Ionic Solids

Crystalline solids formed by **ionic bonding** in which ions are held together by strong electrostatic forces of attraction are called **ionic solids**. The crystals of NaCl, KBr, etc are ionic solids.

Properties

1. **Well-defined** geometrical pattern.
2. **Stable compounds** with **high melting and boiling points**.
3. Do **not exist** as neutral **independent molecules**.
4. **Non-directional** bond.
5. **Structure** dependent on **radius ratio of cation and anion**.
6. **Formula mass** is taken for ionic substances.
7. **Non-conductors** in **solid state**. **Conduct** electricity in **molten state** and **solution form**.

8. Brittleness (very important)

Ionic solids are composed of parallel layers which contain **cations and anions in alternate positions**. When an **external force** is applied, **one layer of the ions slides a bit over the other layer**. Like ions come in front of each other and **repel**. The application of a little external force develops repulsion between two layers causing **brittleness**.

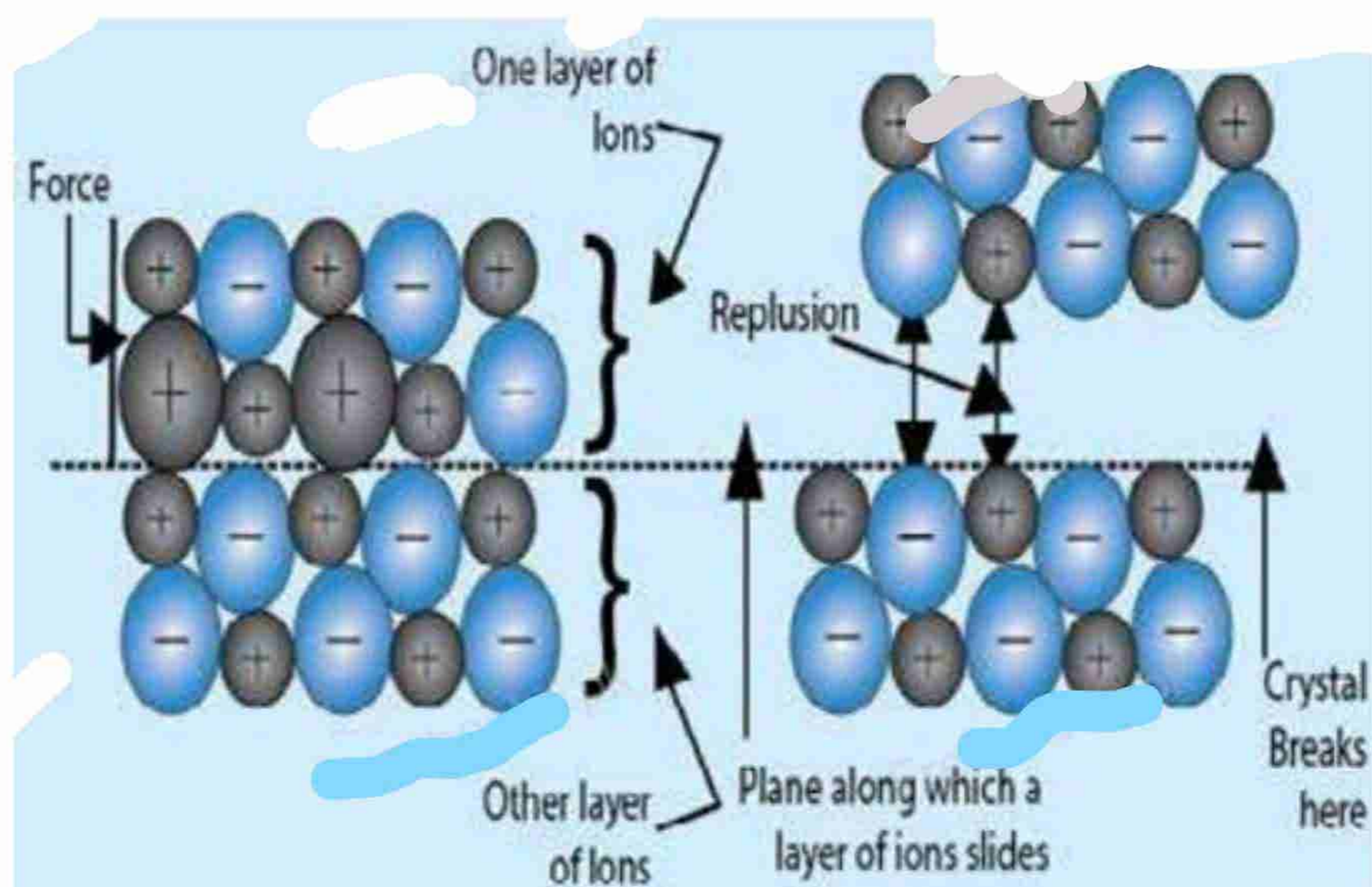

9. High density.

10. Ionic reactions in polar solvents.

11. Fast reactions.

12. Isomorphism and polymorphism observed.

Structure of Sodium chloride

- Each Na^+ ion is surrounded by six chloride ions. Coordination number is six.
- The distance between two nearest ions of the same kind i.e., Cl^- ions is 5.63 \AA .
- The distance between two adjacent ions of different kind is $5.63/2 = 2.815 \text{ \AA}$.
- There are eight Cl^- at the corners of the cube, and each is being shared amongst eight cubes.
- $1/8$ th part of each Cl^- ion is considered for this unit cell.
- One complete Cl^- is contributed by eight corners.
- Six chloride ions are present at the face centres and each is being shared between two cells.
- Per unit cell there are $8/8 + 6/2 = 4 \text{ Cl}^-$ ions.
- There is equal number of Na^+ ions and four NaCl units are present per unit cell.

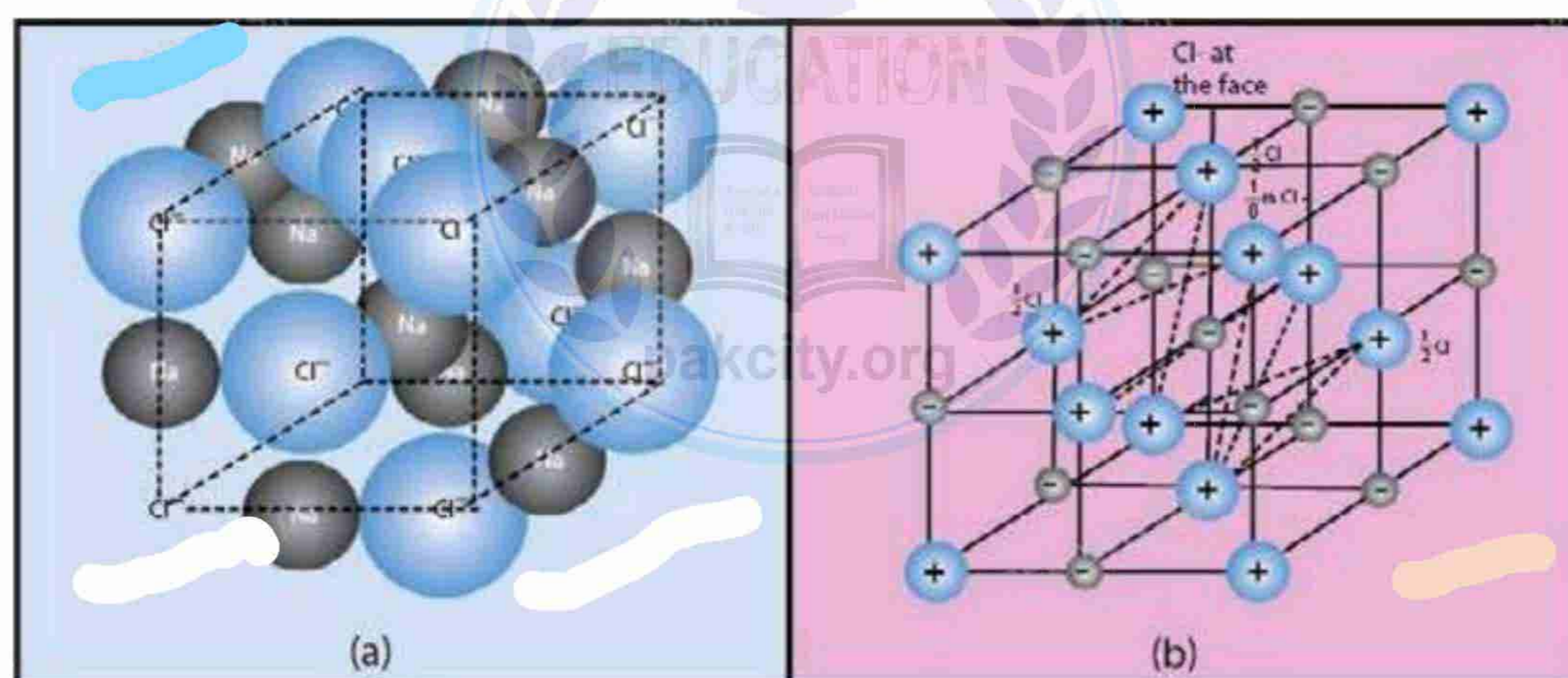

Q. Define lattice energy.

The lattice energy is the **energy released** when **one mole of the ionic crystal** is formed **from the gaseous ions**.

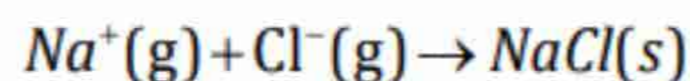

$$\Delta H = -787 \text{ kJ/mol}$$

Covalent Solids

Covalent solids, made of **covalent bond**, are called **atomic solids**. They are composed of neutral atoms of the same or of different elements.

Types

- (i) **Giant molecules** like diamond, silicon carbide or aluminium nitride.
- (ii) **Separate layers** are produced like that of graphite, cadmium iodide and boron nitride.

Properties of Covalent Solids

1. Three dimensional structure.
2. Open structure.
3. Hard with high melting and boiling point.
4. Bad conductors of electricity.
5. Insoluble in polar solvents and soluble in non-polar solvents.
6. Very slow chemical reactions.

Structure of Diamond

- Diamond formed by **sp^3 hybridization**.
- They are directed in space **along the four corners of a tetrahedron**. This is the **unit cell of diamond** and a large number of such unit cells undergo **sp^3 - sp^3 overlapping** to form a **huge structure**.
- The bonds between carbon atoms are covalent which run through the crystal in three-dimensions. All the **bond angles are 109.5°** and the **bond lengths are 154 pm**.



Molecular Solids

Those solid substances in which the particles forming the crystals are **polar or non-polar molecules or atoms** of a substance are called **molecular solids**.

- (i) Dipole-dipole interactions.
- (ii) van der Waals forces.

Ice and sugar polar molecules

Iodine, sulphur, phosphorus and carbon dioxide non-polar molecules.

Properties of Molecular Solids

1. Regular arrangement of atoms.
2. Soft and easily compressible.
3. Volatile with low melting and boiling points.
4. Bad conductors.
5. Low densities.
6. Polar solids in polar solvents, non-polar in non-polar solvents.

Structure of Iodine

- In the solid state the molecules of iodine align in the form of layer lattice.
- I-I bond distance is 271.5 pm and it is appreciably longer than in gaseous iodine (266.6 pm).

Metallic Solids

Electron pool theory

Each atom in a metal crystal loses all of its valence electrons. These **valence electrons form a pool or a gas**. The **positively charged metal ions** are believed to be **held together by electron pool or gas**.

Valence bond theory

L. Pauling treated **metallic bond as covalent** in character. It is assumed that the **covalent bonds are not localized but are highly delocalized** in metal structure.

Molecular orbital theory

The **electrons in the completely filled orbitals are localized**.

Atomic orbitals overlap to form a set of **delocalized orbitals** or **molecular orbitals** which extend over the entire crystal lattice.

Large numbers of closely spaced states are produced known as **bands of energy**. It is also called a **band theory**. The **energy gap between two bands** determines the **properties of the metallic solids**.

Properties of Metallic Solids

1. Good **conductors of electricity**.

Q. Why electrical conduction decreases with increasing temperature?

With the increase in temperature the positive metal ions begin to oscillate and the motion hinders the free movement of mobile electrons between the positive ions. This hindrance decreases the electrical conductivity.

2. **Thermal conductors**.

3. **Metallic luster**.

Q. Why metals have metallic luster?

When light falls on the metallic surface, the incident light collides with the mobile electrons and they are excited. These electrons when de-excited give off some energy in the form of light. This light appears to be reflected from the surface of the metal which gives a shining look.

4. Malleable and ductile.**Structure of metals**

Cubic close packing ABCABC is also called face-centered cubic cell. Closest packed means that the atoms are packed together as closely as possible. In **hexagonal close packing ABAB** layers of spheres are packed so that spheres in alternating layers overlie one another.

Q. In the closest packing of atoms of metals, only 74% space is occupied. Justify.

Cubic close packing is also called ABCABC packing. Although it is close packing even vacant spaces, also called interstices, are left behind which never fill up and occupy 26% empty space in a crystal and only 74% is occupied by atoms.



Chapter 5

Atomic Structure

Discovery of Electron (Cathode Rays)

Discovered by the gas discharge tube experiment.

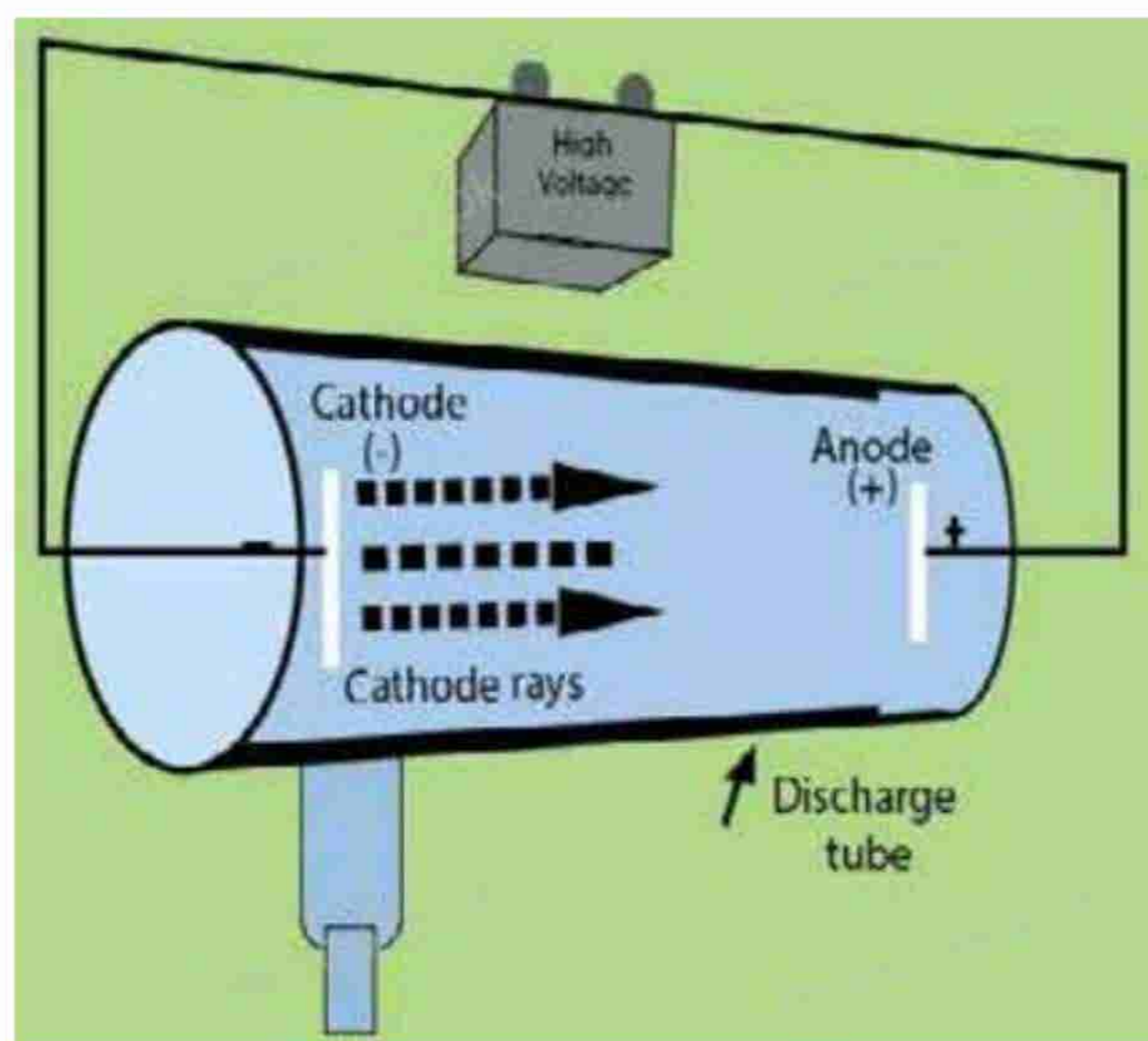

Cathode and anode connected to negative and positive terminals of the battery, respectively.

Vacuum pump adjusts gas pressure.

Voltage: 5000-10,000 V

Gas pressure: Kept low but not below 0.01 torr as then the glow disappears. **Glow depends on the composition of the glass.**

Q. Why the pressure of the gas is kept very low in gas discharge tube experiment?

The pressure of the gas is kept low in the gas discharge tube experiment so there is no charge accumulation and flow of ions is not hindered.

(Learn Properties of Cathode Rays for Short Questions and Long Question)

1. Negatively Charged

Q. How negative charge of cathode rays was proved?

In 1895, J Perrin observed that when **cathode rays** passed between the poles of the magnet, the negatively charged particles were **curved** downward to point 2 (negative plate).

In 1897, J. Thomson passed the **cathode rays** through electric field and found they were **deflected** upwards (positive plate) to point 3.

By controlling the charge on the plates the cathode rays struck at point 1 as both fields cancelled out.

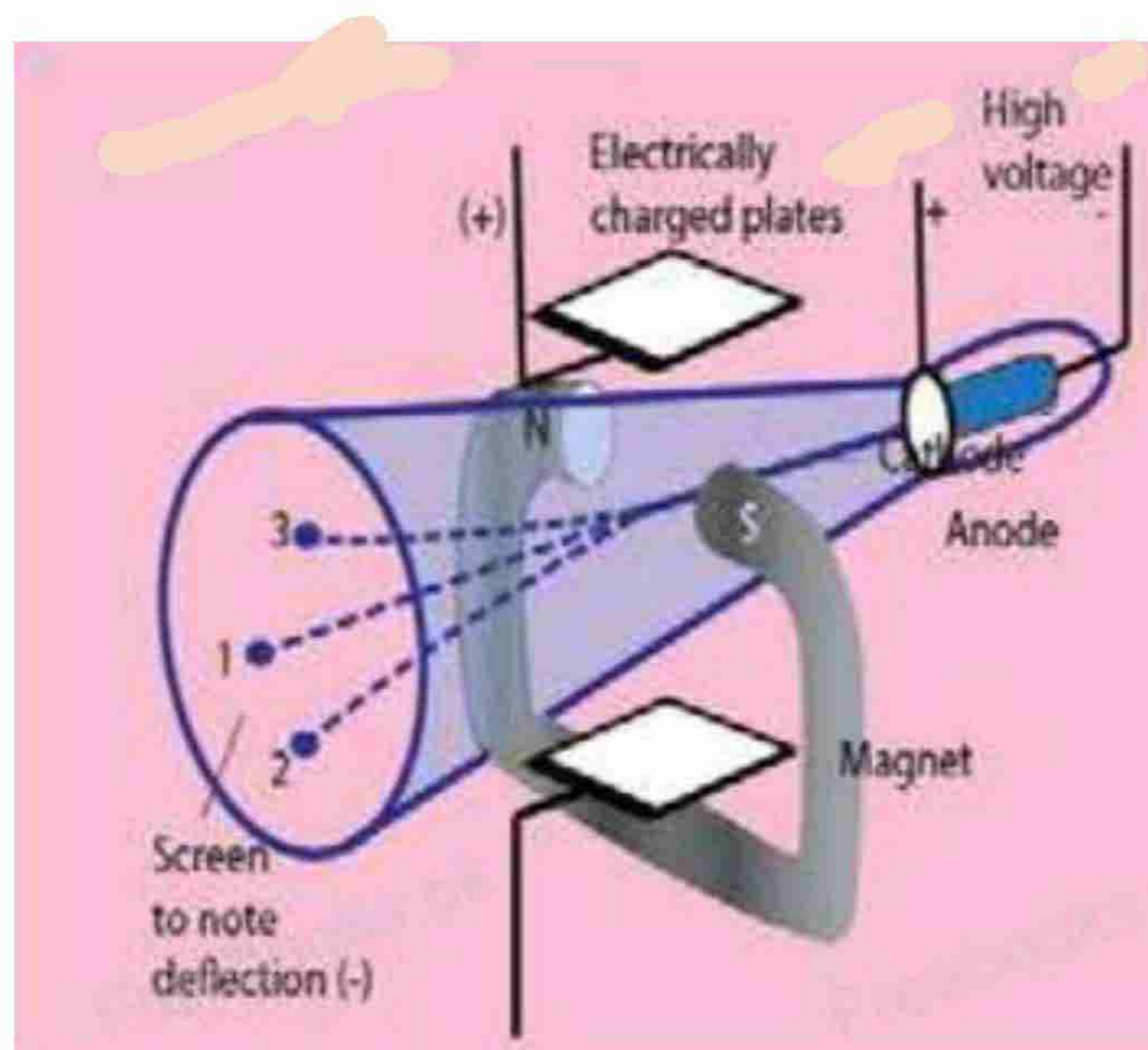

2. Fluorescence Production

Q. How cathode rays produce fluorescence?

Cathode rays **produce greenish fluorescence on striking the walls of the glass tube**. These rays also produce fluorescence in rare earths and minerals. Alumina glows red and tin stone yellow.

3. Travel in Straight Lines

Q. How it is proved that cathode rays travel in straight lines?

Cathode rays **cast a shadow when an opaque object is placed in their path**. This proves that they travel in straight line perpendicular to the surface of cathode.

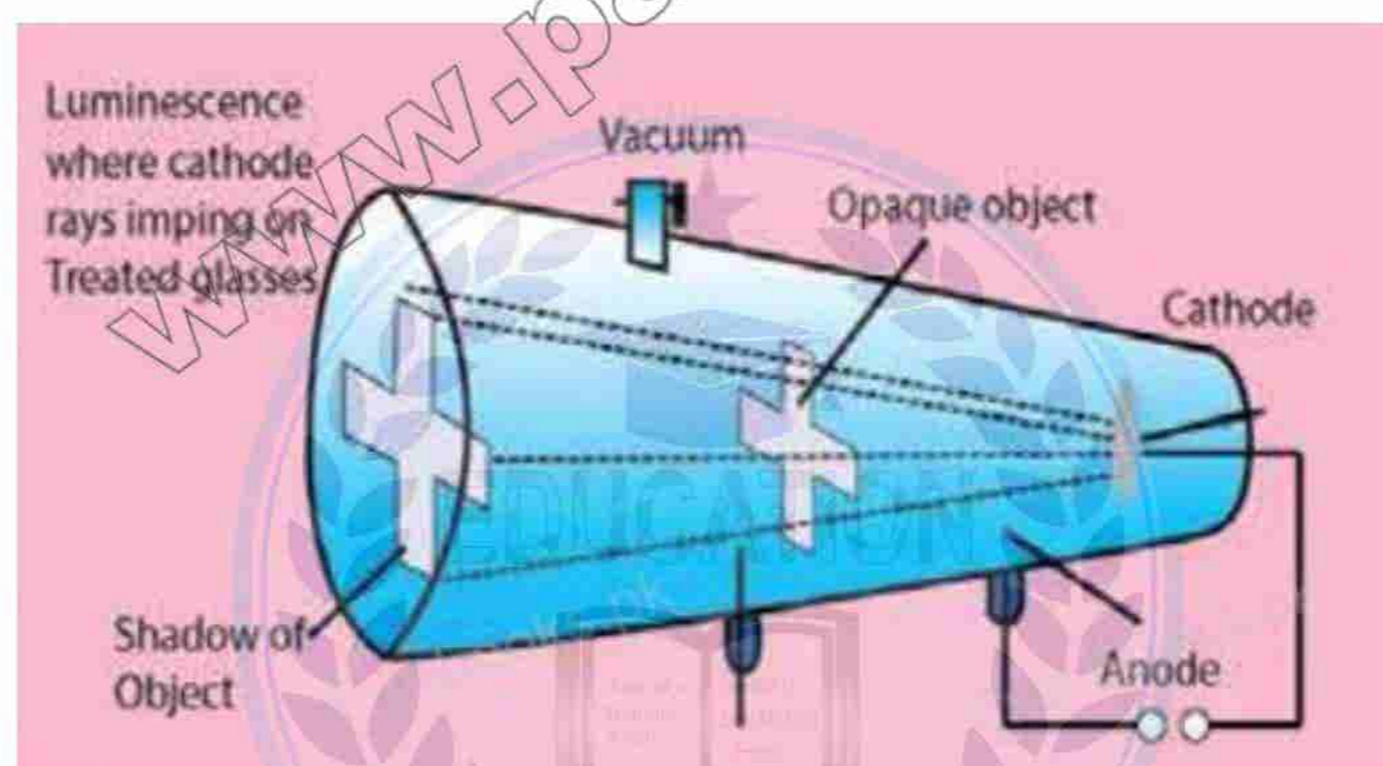

4. Momentum

Q. How it is proved that cathode rays possess momentum?

These rays can **drive a small paddle wheel** placed in their path. This shows that **these rays possess momentum** having a definite mass and velocity.

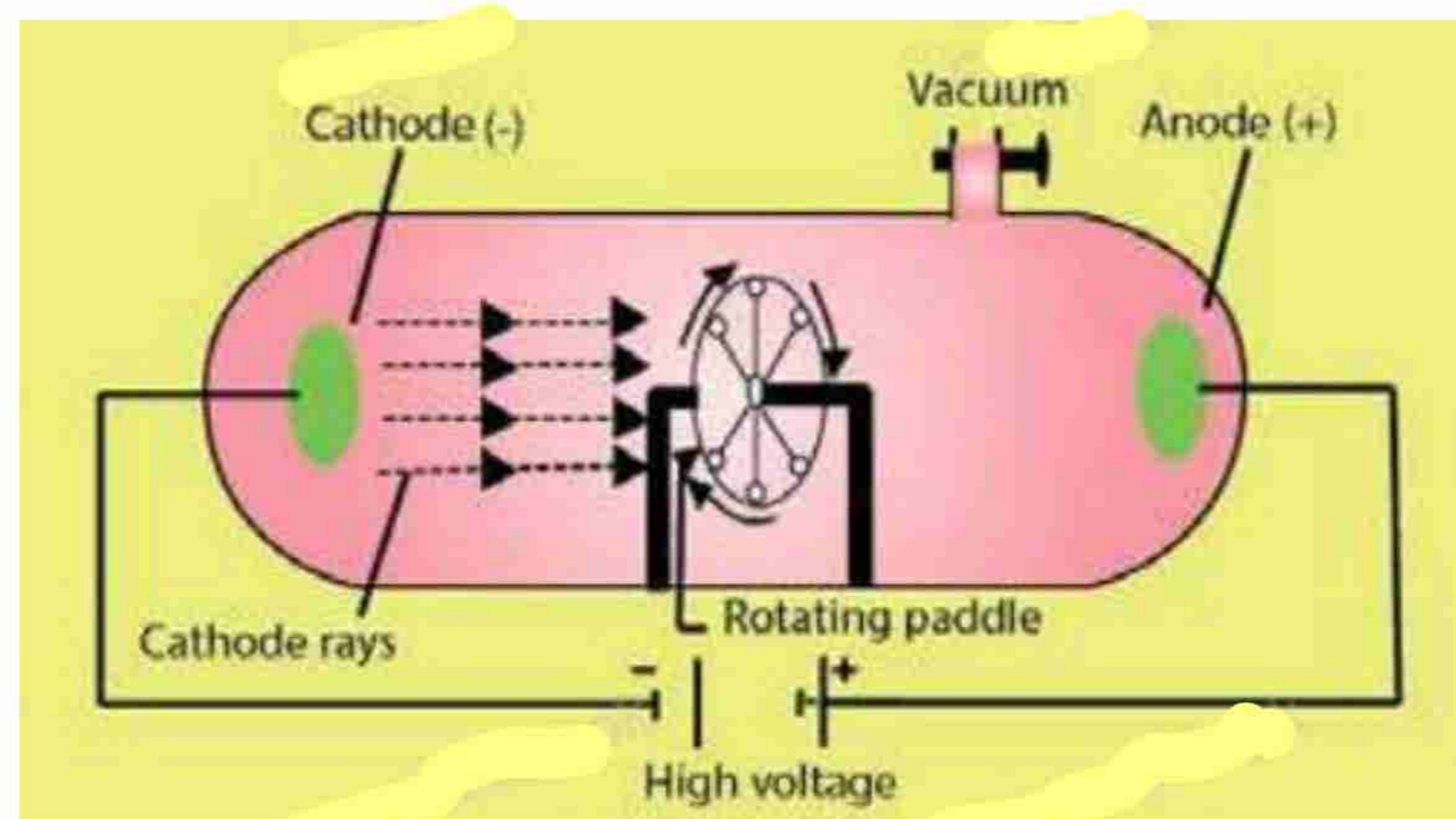

5. X-Ray production

Cathode rays **can produce X-rays when they strike an anode** particularly with large atomic mass.

6. Heat Production

6. Cathode rays **can produce heat when they fall on matter** e.g. when cathode rays from a concave cathode are focused on a platinum foil, it begins to glow.

7. Ionization of gases

Cathode rays can **ionize gases**.

8. Reducing effect

They can **cause a chemical change** because they have a **reducing effect**.

9. Penetrating power

Cathode rays **can pass through a thin metal foil** like aluminum or gold foil.

10. e/m like electrons

Q. Why e/m of cathode rays is independent of the nature of the gas used in discharge tube?

The e/m value of **cathode rays** shows that they are **simply electrons**. Cathode rays consist of streams of negatively charged particles. The charge to mass ratio (e/m) of cathode rays is **same like that of electron** no matter which gas was used in the discharge tube **as the nature of electron is independent of the nature of the gas** from which it is taken out.

Discovery of Proton (Positive Rays)

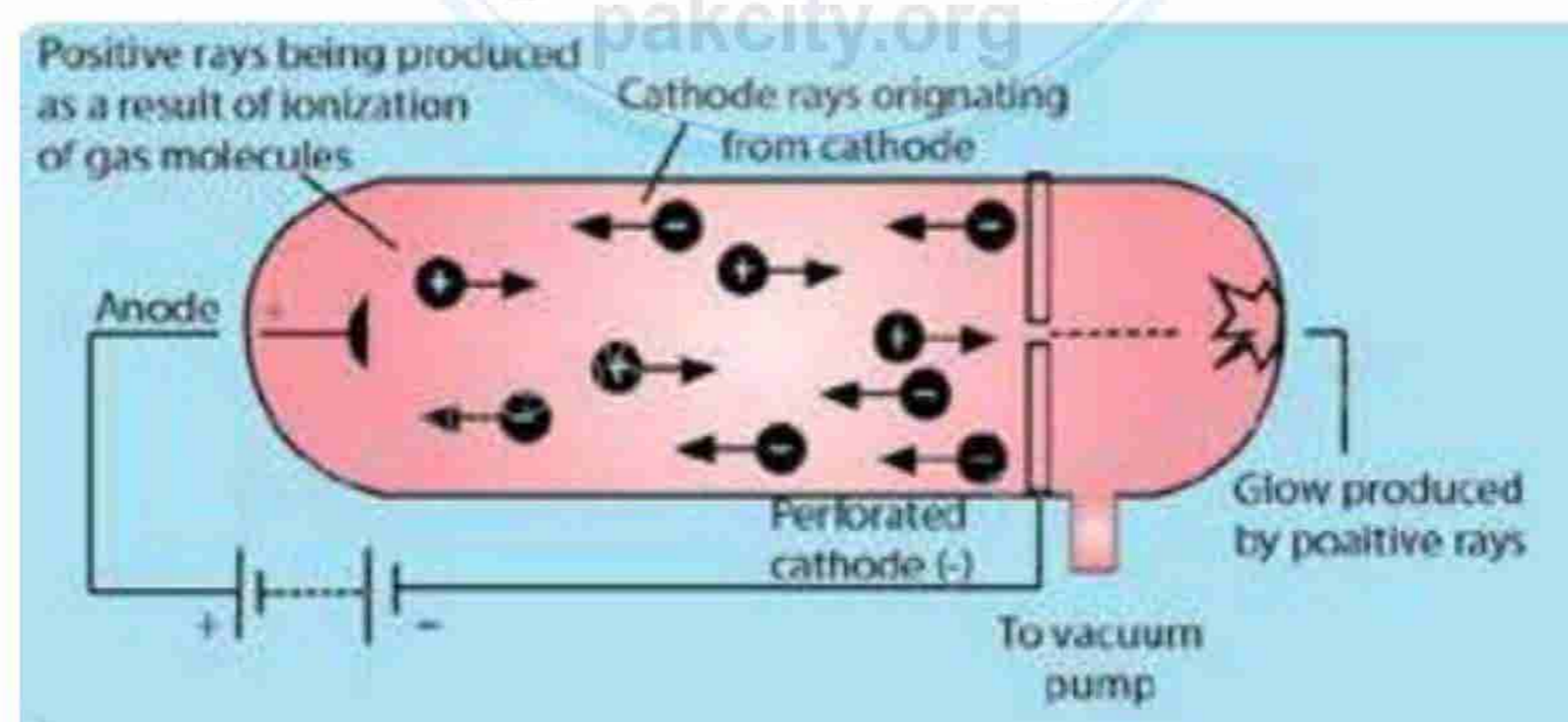

Goldstein discovered positive rays. **Perforated cathode used** and glow produced opposite to anode proving production of positive rays.

Q. Why positive rays are also called canal rays?

Positive rays are produced by using a **perforated cathode** in the discharge tube. As these **perforations serve as canals** for the passage of rays so they are also called **canal rays**.

Q. How positive rays are produced?

The positive rays are produced, when high speed cathode rays strike the molecules of a gas in the discharge tube. They knock out electrons from the gas molecules and positive ions are produced.



Q. Give four properties of positive rays.

1. They are deflected by an electric as well as a magnetic field showing that these are positively charged.
2. These rays travel in a straight line in a direction opposite to the cathode rays.
3. They produce flashes on ZnS plate.
4. The e/m value depends on nature of gas used in the discharge tube.

Q. The e/m value of positive rays depends upon the nature of the gas used in the discharge tube. Justify.

The e/m value of positive rays depends upon the nature of the gas used in the discharge tube as the mass of gas varies and positive rays are ionized gas molecules so the e/m value varies.

Discovery of Neutron

Q. How were neutrons discovered?

Chadwick discovered neutron. A stream of **α -particles** produced from a **polonium source** was directed at **beryllium target**. Some **penetrating radiations** called **neutrons** were produced. The charge detector showed them to be **neutral**.

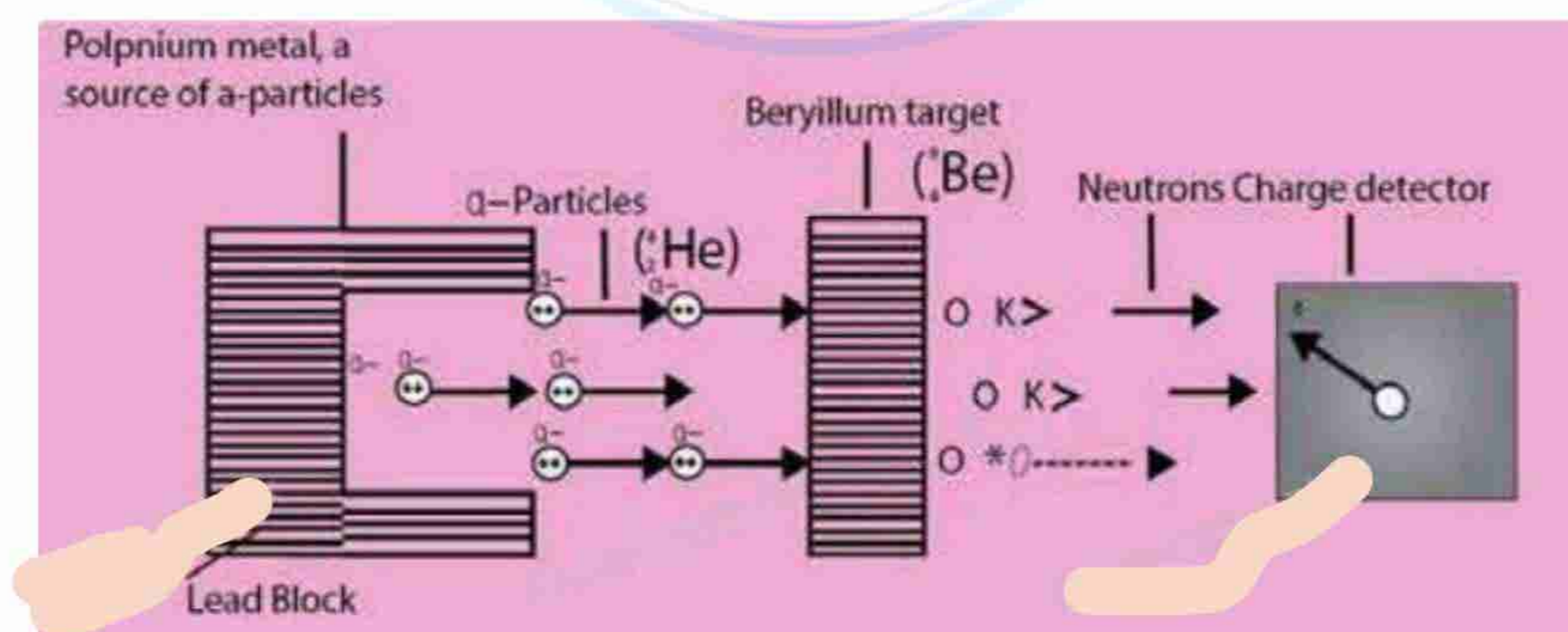
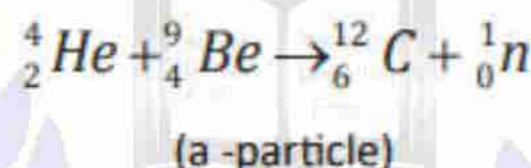

Q. Give any two properties of neutron.

1. Neutrons cannot ionize gases.
2. Neutrons are highly penetrating particles.

Q. What is the difference between slow neutron and fast neutron?

When neutrons travel with energy **1.2 Mev** they are called **fast neutrons** but with energy **below 1ev** are called **slow neutrons**. **Slow neutrons are usually more effective** than fast ones for the fission purposes.

Q. Write nuclear reaction for the decay of neutron.

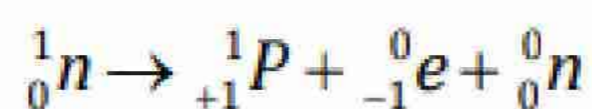

Q. Write nuclear reactions for the production of gamma radiations and beta particles.

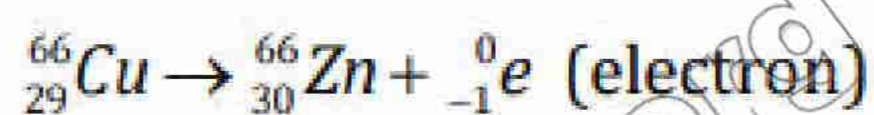
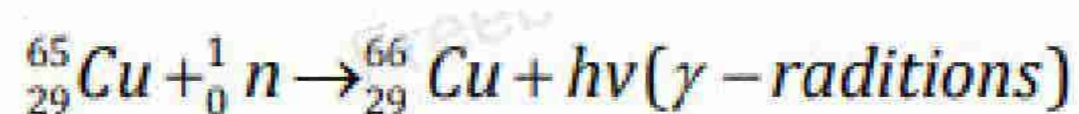

Measurement of e/m Value of Electron

(Learn for Long Question)

J.J Thomson 1897

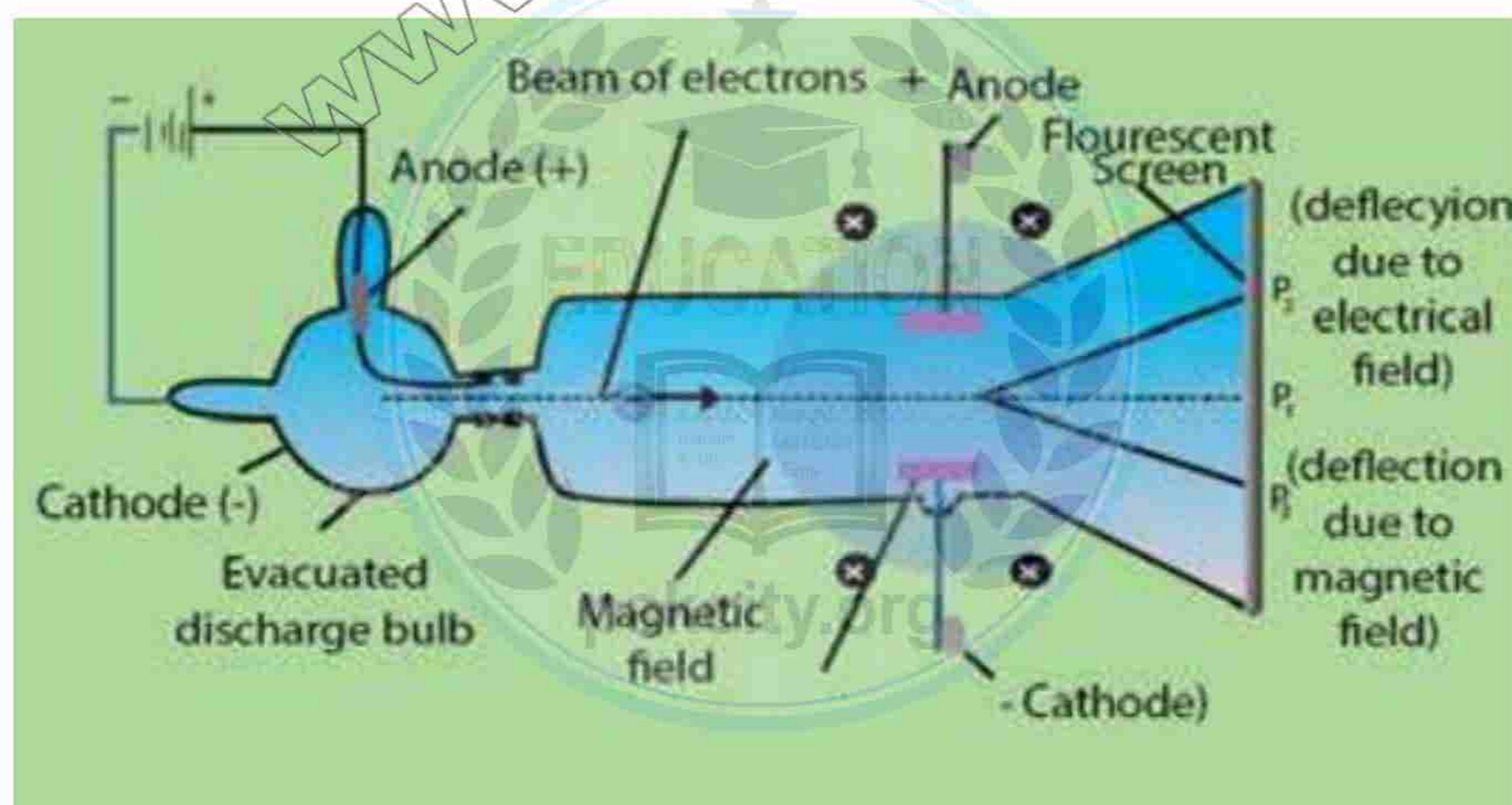

Magnetic field on: Point P₃

Electric field on: Point P₂

Magnetic & Electric field on and adjusted: Point P₁

By comparing the strengths of the two fields the e/m value of electrons is determined = 1.7588×10^{11} coulombs kg^{-1} .

1 kg of electrons have 1.7588×10^{11} coulombs of charge.

Measurement of Charge on Electron-Millikan's Oil Drop Method

(Learn for Long Question)

In 1909 by Millikan

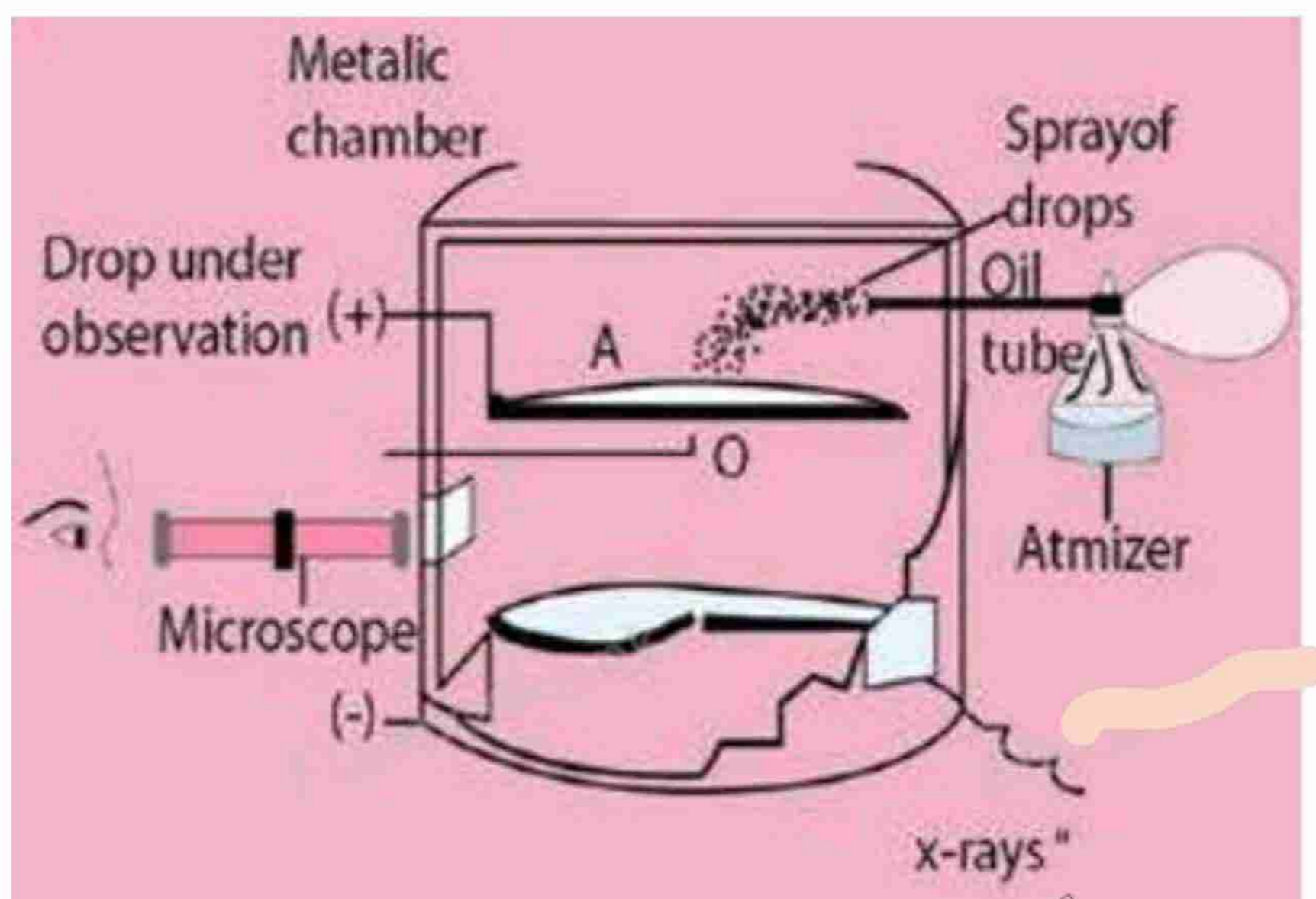

Assembly

A **metallic chamber filled with air.**

Vacuum pump to adjust the pressure.

Two electrodes A and A' for electric field.

An atomizer to create oil droplets.

X-ray source for ionization of air.

Microscope to observe movement of droplet.

Working

A **fine spray of oil droplets** is created by an atomizer.

One droplet passing through the hole in the top plate is **illuminated perpendicularly** and one of them is **observed through a microscope.**

No electric field applied.

The **velocity of the droplet in the direction of gravity** is determined.

$$v_1 \propto mg$$

The **air** between the electrodes is **ionized by X-rays.**

The **droplet takes up an electron** and gets charged.

Electrodes connected to battery.

The droplet moves upwards against the action of gravity.

$$v_2 \propto Ee - mg$$

Dividing both equations

$$\frac{v_1}{v_2} = \frac{mg}{Ee - mg}$$

Vary the electric field, to determine mass, in such a way that the droplet is suspended in the chamber.

Charge 'e' can be calculated.

The **smallest charge** found was 1.59×10^{-19} coulombs close to 1.6022×10^{-19} coulombs recent value.

Q. Calculate mass of electron.

$$\frac{e}{m} = \frac{1.6022 \times 10^{-19} \text{ coulombs}}{\text{Mass of electrons}} = 1.7588 \times 10^{11} \text{ coulombs kg}^{-1}$$

$$\text{Mass of electron} = \frac{1.6022 \times 10^{-19} \text{ coulombs}}{1.7588 \times 10^{11} \text{ coulombs kg}^{-1}}$$

$$\text{Mass of electron} = 9.1095 \times 10^{-31} \text{ kg}$$

Rutherford's Model of Atom

Q. Mention the defects of Rutherford's model of atom.

- (i) It is based on the **laws of the motion and the gravitation**. These laws are **not for the charged bodies like electrons**.
- (ii) The **revolving electron** should emit the energy continuously and by producing a spiral path it **should ultimately fall into the nucleus**. But actually **the atoms don't do that**.
- (iii) The **atom should give continuous spectra but actually line spectra are obtained**.

Planck's Quantum Theory

Q. What is Planck's quantum theory?

Energy travels in a **discontinuous manner** and it is composed of large number of **tiny discrete units** called **quanta**.

Q. Write down any two postulates of Planck's quantum theory.

(i) Energy is not emitted or absorbed continuously, but, in a discontinuous manner in the form of wave packets. Each wave packet is associated with a definite amount of energy. The quantum of energy is called photon for light.

(ii) The amount of energy of quantum is proportional to the frequency (ν) of the radiation.

Bohr's Model of Atom

Very Important Topic of the Chapter

(Learn All Sub-Topics of Bohr's Model of Atom for Long Questions from Book)

Q. How do you justify that the distances between adjacent orbits of Hydrogen atom go on increasing from lower to the higher orbits?

From equation of radius for hydrogen atom

$$r = 0.529 \text{ \AA} \times n^2$$

where

$$n = 1 \quad r_1 = 0.529 \times (1)^2 = 0.529 \text{ \AA}$$

$$n = 2 \quad r_2 = 0.529 \times (2)^2 = 2.11 \text{ \AA}$$

$$n = 3 \quad r_3 = 0.529 \times (3)^2 = 4.75 \text{ \AA}$$

$$n = 4 \quad r_4 = 0.529 \times (4)^2 = 8.4 \text{ \AA}$$

Distance gaps go on increasing from lower to higher orbits. Therefore,

$$r_2 - r_1 < r_3 - r_2 < r_4 - r_3 < \dots \dots \dots \text{SO ON.}$$

The second orbit is four times away from the nucleus than first orbit, third orbit is nine times away and similarly fourth orbit is sixteen times away.

Q. How do you prove that the energy associated with the electron which is revolving around the nucleus of H-atom is negative?

The work done is the potential energy of electron, so

$$\text{Work done} = E_{\text{potential}} = -\frac{Ze^2}{4\pi\epsilon_0 r}$$

The total energy (E) of the electron, is the sum of kinetic and potential charges.

$$\text{So, } E = E_{\text{kinetic}} + E_{\text{potential}}$$

$$= \frac{1}{2} mv^2 - \frac{Ze^2}{4\pi\epsilon_0 r}$$

$$mv^2 = \frac{Ze^2}{4\pi\epsilon_0 r}$$

$$E = \frac{Ze^2}{8\pi\epsilon_0 r} - \frac{Ze^2}{4\pi\epsilon_0 r}$$

$$E = -\frac{Ze^2}{8\pi\epsilon_0 r}$$

Q. How do you come to know that the velocities of electrons in higher orbits are less than those in lower orbits of hydrogen atom?

According to Bohr's proposals, the centrifugal force of the electron is equal to the force of attraction between nucleus and electron.

$$\frac{mv^2}{r} = \frac{Ze^2}{4\pi\epsilon_0 r^2}$$

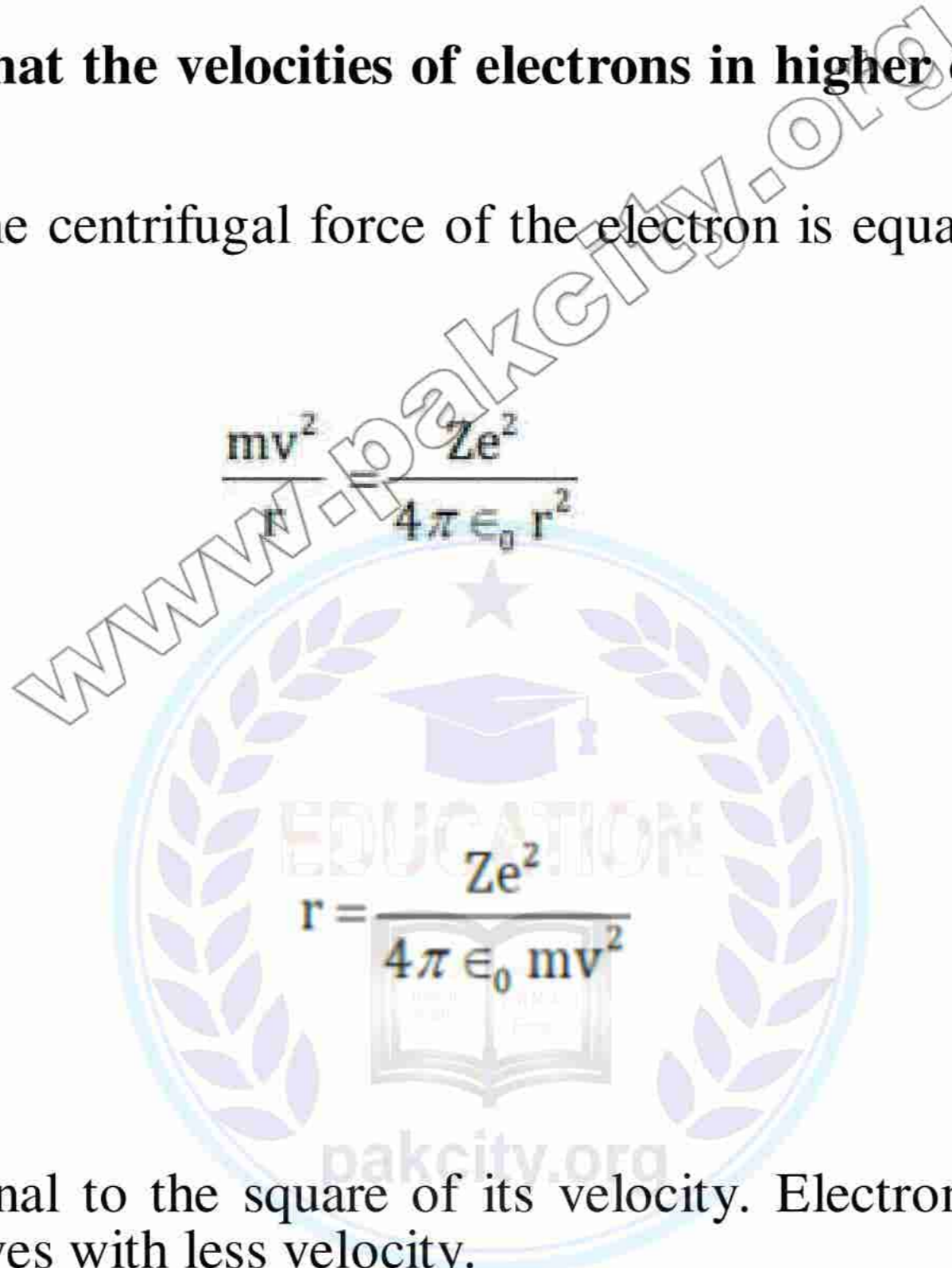
$$r = \frac{Ze^2}{4\pi\epsilon_0 mv^2}$$

The radius is inversely proportional to the square of its velocity. Electron should move faster nearer to the nucleus and in higher orbits it moves with less velocity.

Q. Energy of an electron is inversely proportional to 'n²' but energy of higher orbits is always greater than those of the lower orbits. Why?

The formula for the energy of an electron revolving in any orbit is given by the equation:

$$E_n = -2.178 \times 10^{-18} \left[\frac{1}{n^2} \right] \text{J}$$

Negative value shows that greater the value of n greater the energy of electron.

Q. The energy difference between adjacent levels goes on decreasing sharply. Why?

Substituting the values of n as 1, 2, 3, 4, 5, etc. in equation, we get the energy associated with an electron revolving in 1st, 2nd, 3rd, 4th and 5th orbits of H-atoms.

$$E_1 = -\frac{1313.31}{1^2} = -1313.31 \text{ kJmol}^{-1}$$

$$E_2 = -\frac{1313.31}{2^2} = -328.32 \text{ kJmol}^{-1}$$

$$E_3 = -\frac{1313.31}{3^2} = -145.92 \text{ kJmol}^{-1}$$

$$E_4 = -\frac{1313.31}{4^2} = -82.08 \text{ kJmol}^{-1}$$

$$E_5 = -\frac{1313.31}{5^2} = -52.53 \text{ kJmol}^{-1}$$

$$E_\infty = -\frac{1313.31}{\infty^2} = 0 \text{ kJmol}^{-1} \text{ (electron is free from the nucleus)}$$

$$E_2 - E_1 = (-328.32) - (-1313.31) = 984.99 \text{ kJmol}^{-1}$$

$$E_3 - E_2 = (-145.92) - (-328.32) = 182.40 \text{ kJmol}^{-1}$$

$$E_4 - E_3 = (-82.08) - (-145.92) = 63.84 \text{ kJmol}^{-1}$$

$$E_2 - E_1 > E_3 - E_2 > E_4 - E_3$$

Energy difference between lower orbits is greater and energy difference between higher orbits is lower.

Q. How Bohr's model of H-atom can help us to justify the ionization potential of H-atom?

Substituting the values of n as 1, 2, 3, 4, 5, etc. in equation we get the energy associated with an electron revolving in various orbits of hydrogen atom.

$$E_1 = -\frac{1313.31}{1^2} = -1313.31 \text{ kJmol}^{-1}$$

$$E_\infty = -\frac{1313.31}{\infty^2} = 0 \text{ kJmol}^{-1} \text{ (electron is free from the nucleus)}$$

$$E_2 - E_1 = (-328.32) - (-1313.31) = 984.99 \text{ kJmol}^{-1}$$

$$E_\infty - E_1 = 0 - (-1313.31) = 1313.31 \text{ kJmol}^{-1}$$

The ionization energy of hydrogen.

Q. Write any two defects of Bohr's model of atom.

1. Bohr's theory can successfully explain the origin of the spectrum of H-atom and ions like He^{+1} , Li^{+2} and Be^{+3} , etc. These are all one electron systems. But this theory is not able to explain the origin of the spectrum of multi-electrons or poly-electrons system like He, Li and Be etc.

2. When the spectrum of hydrogen gas is observed by means of a high resolving power spectrometer, the individual spectral lines are replaced by several very fine lines. The $\text{H}\alpha$ line in the Balmer series is found to consist of five-component lines. This is called fine structure or multiple structure. The appearance of several lines in a single line suggests that only one quantum number is not sufficient to explain the origin of various spectral lines.

Q. What is Zeeman effect and Stark effect?

When the **excited atoms of hydrogen** are placed **in a magnetic field**, its spectral lines are further split up into closely spaced lines. This type of splitting of spectral lines is called **Zeeman effect**.

When the **excited hydrogen atoms** are placed **in an electrical field**, then similar **splitting of spectral lines** takes place which is called **Stark effect**.

Spectrum



Q. Define spectrum.

A visual display of the white light components when it is passed through a prism is called a spectrum.

Q. What is the difference between continuous spectrum and line spectrum?

In continuous spectrum, the **boundary line between the colours cannot be marked**. The **colours diffuse into each other**. **One colour merges into another** without any dark space. Characteristic of **matter in bulk**. **Example is rainbow** from sun and incandescent light solids.

When an **element or its compound is volatilized on a flame** and the **light emitted is seen through a spectrometer**, we see **distinct lines separated by dark spaces**. This type of spectrum is called **line spectrum or atomic spectrum**.

Q. What is the difference between atomic emission spectrum and atomic absorption spectrum?

When **solids are volatilized or gaseous elements are heated radiations of certain wavelengths are emitted**. The spectrum had **bright lines against a dark background**. This is called **atomic emission spectrum**.

When a beam of white light is passed through a gaseous element, it absorbs certain wavelengths. The spectrum of this radiation is called an **atomic absorption spectrum**. The spectrum appears as **dark lines and the background is bright**.

X-Rays and Atomic Number

Q. State Moseley's law.

The frequency of a spectral line in X-ray spectrum varies as the square of atomic number of an element emitting it.

$$\sqrt{\nu} = a(Z-b)$$

'a' and 'b' are the constants characteristic of the metal.

a= proportionality constant

b= screening constant of the metals.

Q. What is the importance of Moseley's law?

- (i) Moseley arranged K and Ar, Ni and Co in a proper way in Mendeleev's periodic table.
- (ii) This law has led to the discovery of many new elements like Tc(43), Pr(59), Rh(45).
- (iii) The atomic numbers of rare earths have been determined by this law.

Heisenberg's Uncertainty Principle

Q. State Heisenberg's uncertainty principle and give its equation.

It states that certainty in the determination of momentum introduces uncertainty in the determination of position and vice versa.

Suppose that Δx is the uncertainty in the measurement of the position and Δp is the uncertainty in the measurement of momentum of an electron, then the mathematical expression is:

$$\Delta x \Delta p \geq \frac{h}{4\pi}$$

Orbital

The volume of space in which there is **95% chance of finding an electron** is called atomic orbital.

Shapes of orbitals

s-subshell

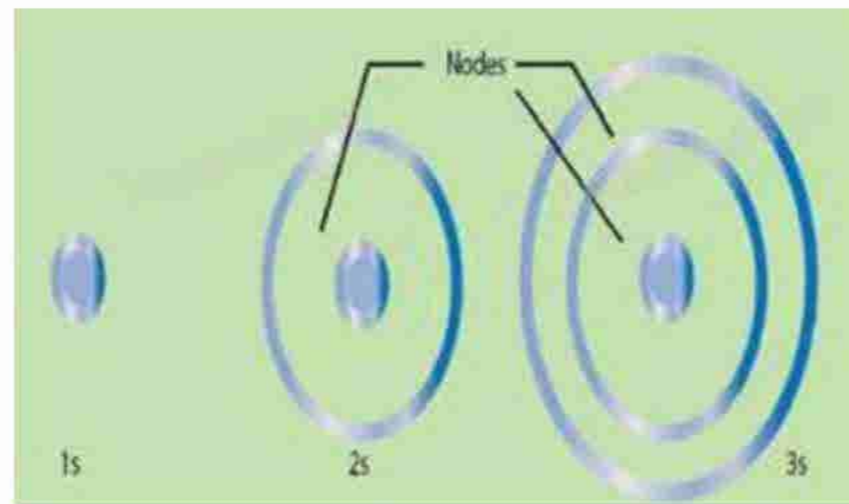

p-subshell

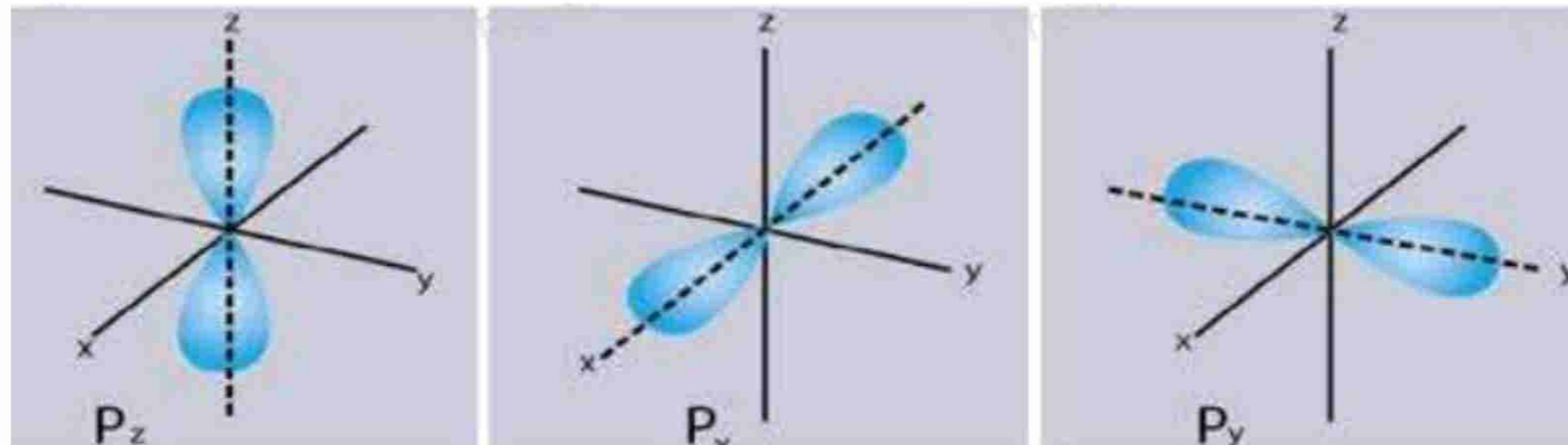

d-subshell

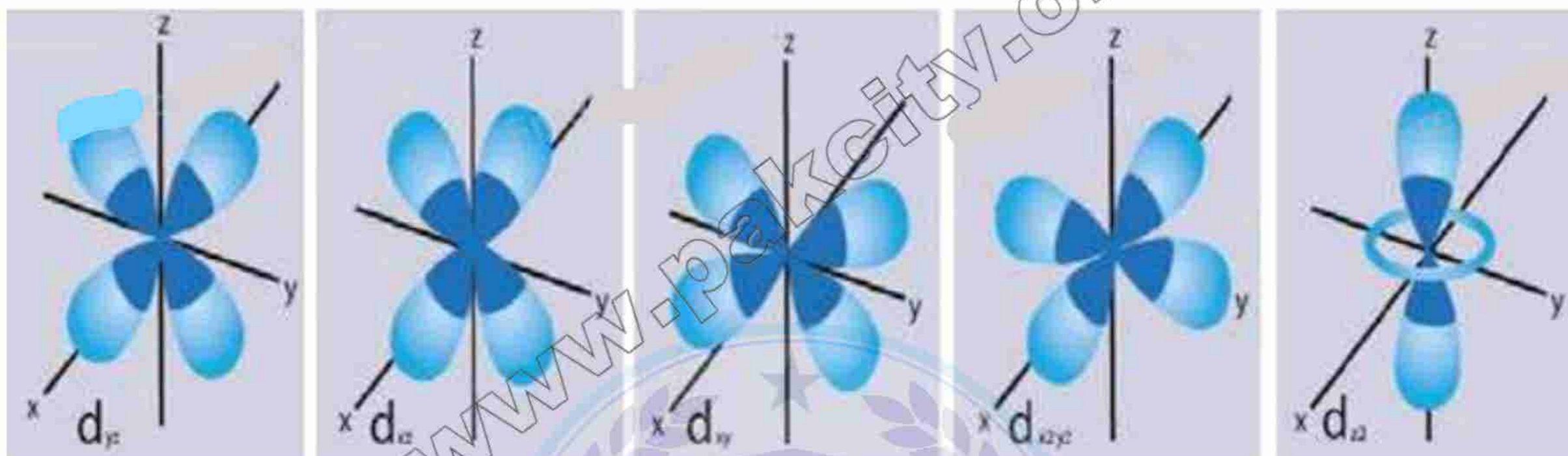

Quantum Numbers

(Learn for Short Questions and Long Question)

Q. Define quantum numbers. Mention their names.

Quantum numbers are the sets of numerical values which give the acceptable solutions to Schrodinger wave equation for hydrogen atom. Quantum numbers serve as identification numbers or labels, which completely describe an electron. These quantum numbers specify position of electron in an atom.

Names

- | | |
|----------------------------------|----------------------------------|
| (1) Principal quantum number (n) | (2) Azimuthal quantum number (l) |
| (3) Magnetic quantum number (m) | (4) Spin quantum number (s) |

Q. Briefly tell about principal quantum number/azimuthal quantum number/magnetic quantum number and spin quantum number.

Principal quantum number

- Represent **different energy levels** denoted by 'n'
- **Non-zero positive integers** up to infinity

$$n=1,2,3,4,5,-----$$

- **Location of electron** in an atom.
- **Size/radius of electronic shell.**
- **Energy of electron.**

Azimuthal quantum number

- Represent **different sub-shells** denoted by 'l'
- The values are: $l=0,1,2,3$
- Designated by s, p, d, f

$l=0$ s-subshell spherical

$l=1$ p-subshell dumb-bell

$l=2$ d-subshell (complicated shape)

$l=3$ f-subshell (complicated shape)

Magnetic quantum number

- Represents **alignment of the sub-shells in the magnetic field** denoted by 'm'.
- Values of magnetic quantum number are:

$$m=0, \pm 1, \pm 2, \pm 3, \dots$$

Spin quantum number

An **electron** rotates or **spins about its own axis** (self-rotation).

It can be **clockwise** or **anti-clockwise** direction.

Clockwise motion is shown as **+1/2** and **anti-clockwise** as **-1/2**.

$l = 0$	s-subshell	$m=0$
$l = 1$	p-subshell	$m=0, \pm 1$ (p-subshell has three degenerate orbitals)
$l = 2$	d-subshell	$m=0, \pm 1, \pm 2$ (d-subshell has five degenerate orbitals)
$l = 3$	f-subshell	$m=0, \pm 1, \pm 2, \pm 3$ (f-subshell has seven degenerate orbitals)

$n = 1$	K-shell	$\{\ell = 0$	{s-subshell	should be called as	1s
$n = 2$	L-shell	$\begin{cases} \ell = 0 \\ \ell = 1 \end{cases}$	$\begin{cases} \text{s-subshell} \\ \text{p-subshell} \end{cases}$		$\begin{matrix} 2s \\ 2p \end{matrix}$
$n = 3$	M-shell	$\begin{cases} \ell = 0 \\ \ell = 1 \\ \ell = 2 \end{cases}$	$\begin{cases} \text{s-subshell} \\ \text{p-subshell} \\ \text{d-subshell} \end{cases}$		$\begin{matrix} 3s \\ 3p \\ 3d \end{matrix}$
$n = 4$	N-shell	$\begin{cases} \ell = 0 \\ \ell = 1 \\ \ell = 2 \\ \ell = 3 \end{cases}$	$\begin{cases} \text{s-subshell} \\ \text{p-subshell} \\ \text{d-subshell} \\ \text{f-subshell} \end{cases}$		$\begin{matrix} 4s \\ 4p \\ 4d \\ 4f \end{matrix}$

Q. Calculate number of electrons in s,p,d and f-subshells.

The formula for calculating electrons is $2(2l+1)$:

$\ell = 0$	s-subshell	total electrons = 2
$\ell = 1$	p-subshell	total electrons = 6
$\ell = 2$	d-subshell	total electrons = 10
$\ell = 3$	f-subshell	total electrons = 14

Rules for Distribution of Electrons

n+l rule

This rule says that if sub-shells are arranged in the increasing order of $(n + l)$ values, then that sub-shell is placed first whose n value is smaller.

Aufbau principle

The electrons should be filled in energy sub-shells in order of increasing energy values. The electrons are first placed in 1s, 2s, 2p and so on.

Pauli's Exclusion Principle

It is impossible for two electrons residing in the same orbital of a poly-electron atom to have the same values of four quantum numbers. OR Two electrons in the same orbital should have opposite

Hund's Rule

If degenerate orbitals are available and more than one electrons are to be placed in them, they should be placed in separate orbitals with the same spin rather than putting them in the same

Q. Write down electronic configuration of Fe (26), Br (35), P (15), Cu (29) and Cr (24).

Fe (26) [Ar] $4s^2 3d^2 xy 3d^2 yz 3d^2 xz 3d^1 x^2-y^2 3d^1 z^2$

P (15) [Ne] $3s^2 3p_x^1 3p_y^1 3p_z^1$

Br (35) [Ne] $4s^2 3d^{10} 4p_x^2 4p_y^2 4p_z^1$

Cu (29) [Ne] $4s^1 3d^2 xy 3d^2 yz 3d^2 xz 3d^2 x^2-y^2 3d^2 z^2$

Cr (24) [Ar] $4s^1 3d^2 xy 3d^2 yz 3d^2 xz 3d^2 x^2-y^2 3d^2 z^2$



Chapter 6

Chemical Bonding

Q. What is octet rule? Give one example of compound which obeys it and two examples of compounds which do not obey it.

Attaining eight electrons in the outermost shell by gaining, losing or sharing electrons is called octet rule. For example, HF formation.

The formation of PF_5 , SF_6 and BCl_3 is not according to octet rule.

Q. Bond distance is the compromise distance between the two atoms making molecule. OR 75.4 pm is the bond distance between two hydrogen atoms. Justify.

When two atoms approach each other then attractive forces and repulsive forces operate. Attractive forces are between the nucleus of one atom and electrons of the other atom and repulsive forces are between the nuclei and electrons of both the atoms. A point is reached where attractive forces dominate and repulsive forces are minimized. This is the point where bond is formed so bond distance is called the compromise distance between two atoms making a molecule.

In H_2 molecule compromised distance between the two hydrogen atoms is 75.4pm, which is also called equilibrium bond distance or bond length of H_2 molecule.

Atomic Sizes

(Learn for Short Questions and Long Question)

The **atomic radius** means the average distance between the nucleus of the atom and its outermost electronic shell.

Q. What is the trend of atomic radius in the periodic table?

Atomic radius **decreases from left to right** because the **effective nuclear charge increases** and **shielding effect remains constant**. The outer shell electrons are held with greater force by the nucleus.

Atomic radius **increases from top to bottom** because the **effective nuclear charge decreases** and **shielding effect increases**. The outer shell electrons are held with less force by the nucleus.

Q. Why the radius of an atom can't be determined precisely?

The radius of an atom cannot be determined precisely due to the following reasons:

(i) There is **no sharp boundary of an atom**. The probability of finding an electron never becomes exactly zero even at large distances from the nucleus.

(ii) The **electronic probability distribution is affected by neighbouring atoms**. For this reason, the size of an atom may change from one compound to another.

Ionic Radius

The ionic radius of an ion is the radius of the ion while considering it to be spherical in shape.

$$R = r_+ + r_-$$

$$r_- = R - r_+$$

The distance between K^+ and Cl^- ions in potassium chloride

$$R = 133\text{pm} + 181\text{pm} = 314\text{ pm}$$

Covalent Radius

The covalent radius of an element is defined as **half of the single bond length** between two similar atoms covalently bonded in a molecule.

C-Cl bond length in CH_3Cl = 176.7 pm.

The covalent radius of Cl-atom = 99.4 pm.

The covalent radius of C-atom = $176.7 - 99.4 = 77.3$ pm.

Q. Why is the size of cation smaller than parent atom?

The cation has more number of protons than electrons so the pull of greater protons decreases the size. The radius of Na atom reduces from 186 pm to 95 pm after conversion into Na^+ ion.

Q. Why the size of anion larger than parent atom? OR Why the radius of Cl^- ion increases from 99 pm to 181 pm?

The anion has more number of electrons than protons so the pull of protons is less on electrons and size increases. The ionic radius of Cl^- ion increases from 99 pm to 181 pm.

Ionization Energy

(Learn for Short Questions and Long Question)

The ionization energy of an element is the **minimum energy** required to remove an electron from its gaseous atom to form an ion.



Q. What is the trend of ionization energy in the periodic table?

Ionization energy increases from left to right because the effective nuclear charge increases, atomic size decreases, shielding effect remains constant so hold of nucleus on the outer shell electrons increases.

Ionization energy decreases from top to bottom because the effective nuclear charge decreases, atomic size increases, shielding effect increases so hold of nucleus on the outer shell electrons decreases.

Q. Ionization energy is an index of the metallic character. Justify.

Ionization energy is an index to the metallic character. The elements having low ionization energies are metals and those having high ionization energies are non-metals. Those with intermediate values are mostly metalloids.

Electron Affinity

(Learn for Short Questions and Long Question)

The electron affinity of an atom is the **energy released when an electron adds to an empty or partially filled orbital of an isolated gaseous atom** in its valence energy level to form an anion having a unit negative charge.



Q. What is the trend of electron affinity in the periodic table?

Electron affinity increases from left to right as the effective nuclear charge increases, shielding effect remains constant, atomic radius decreases and hold of nucleus on outer shell electrons increases.

Electron affinity decreases from top to bottom as the effective nuclear charge decreases, shielding effect increases, atomic radius increase and hold of nucleus on outer shell electrons decreases.

Electronegativity**(Learn for Short Questions and Long Question)**

The **tendency of an atom to attract a shared electron pair towards itself** is called its electronegativity.

Q. What is the trend of electronegativity in the periodic table?

Electronegativity **increases from left to right** as the **effective nuclear charge increases**, **shielding effect remains constant**, **atomic radius decreases** and hold of nucleus on outer shell electrons increases.

Electronegativity **decreases from top to bottom** as the **effective nuclear charge decreases**, **shielding effect increases**, **atomic radius increases** and hold of nucleus on outer shell electrons decreases.

Types of Bonds**(Learn for Long Questions)****Ionic Bond**

Ionic bond is formed by the **complete transfer of electron or electrons** from an atom with low ionization energy to another atom with high electron affinity.

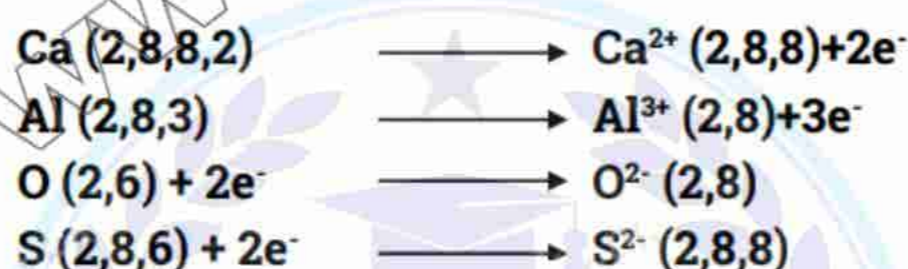
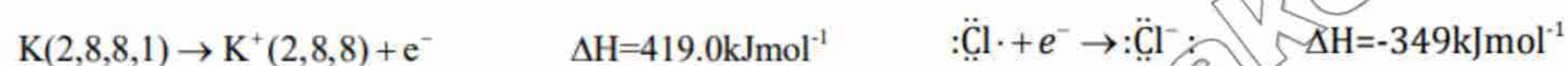
**Q. No bond in chemistry is 100% ionic. Justify.**

For a compound to be **100% ionic** the **electronegativity difference** between the elements must be **4.0**. So, no bond in chemistry is 100% ionic in nature. **Highest ionic character** is present in **CsF** because Cesium is least electronegative and fluorine is most electronegative element. **Difference of electronegativity** is $4 - 0.7 = 3.3$. **Cesium fluoride** is **92% ionic** and has 8% covalent character in it. **NaCl** is **72% ionic** and 28% covalent.

Covalent Bond

A covalent bond is **formed by the mutual sharing of electrons** between two atoms.

It can be **polar** or **non-polar**

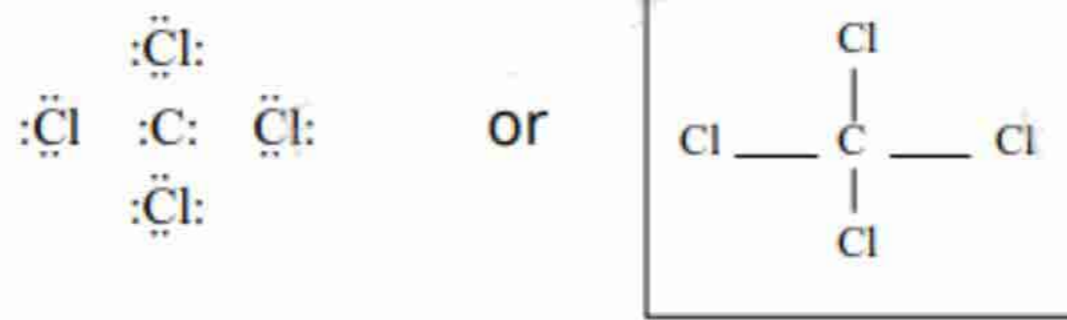
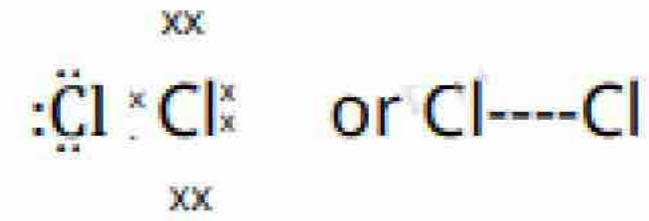
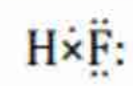
Tetrachloromethane**Hydrogen****Chlorine****Hydrogen fluoride**

or

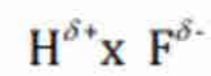
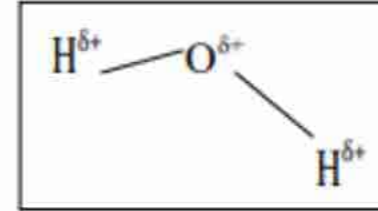
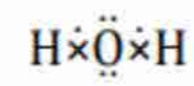
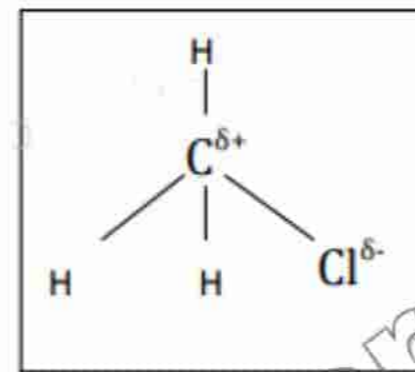
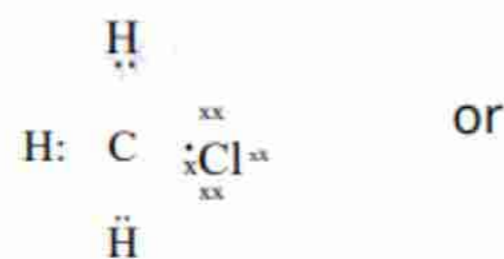
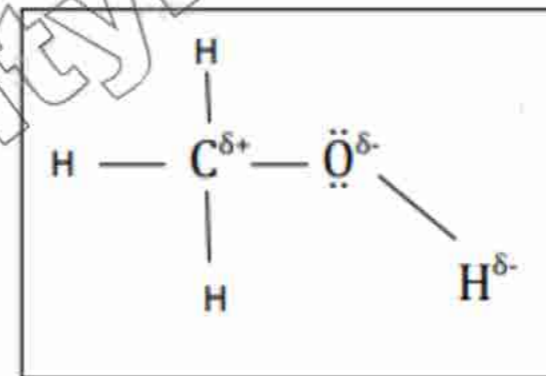
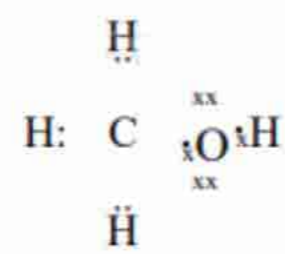
**Water****Methyl chloride****Methanol****Oxygen**

or

**Nitrogen**

or

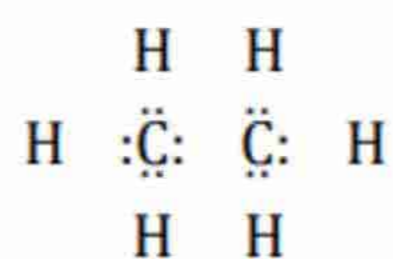

Ethan

or

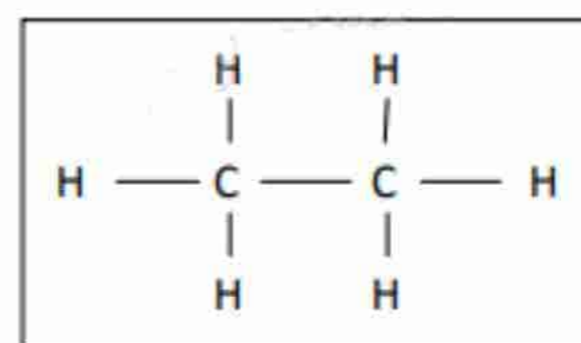
**Carbon dioxide**

or

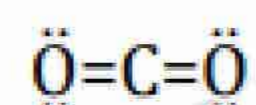
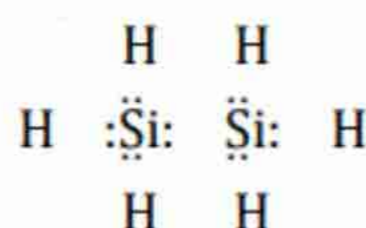
**Disilane**

or

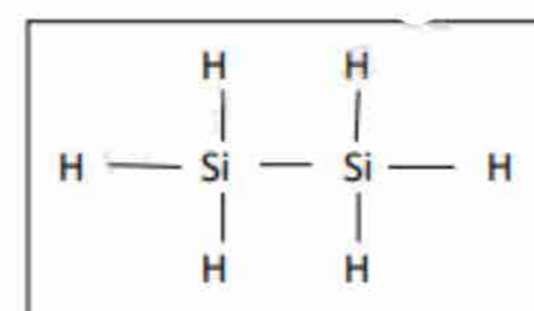
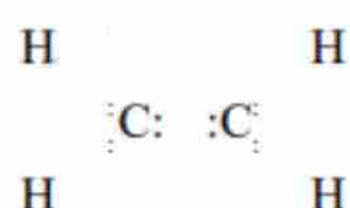
**Ethene**

or

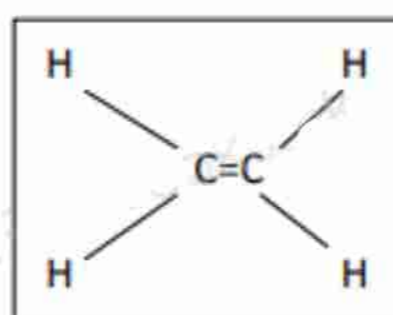
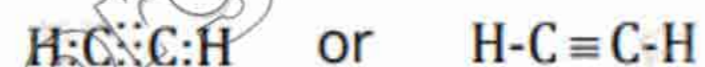
**Ethyne****Coordinate Covalent Bond**

A coordinate covalent bond is formed between two atoms when the **shared pair of electrons is donated by one of the bonded atoms.**

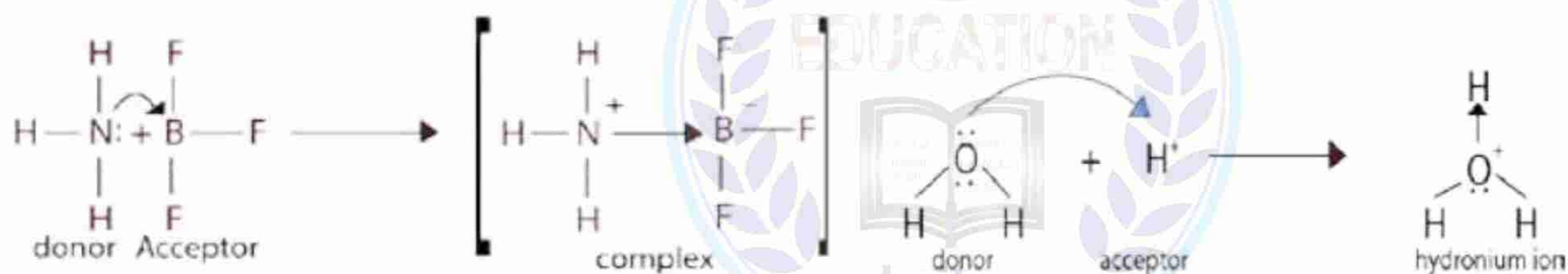

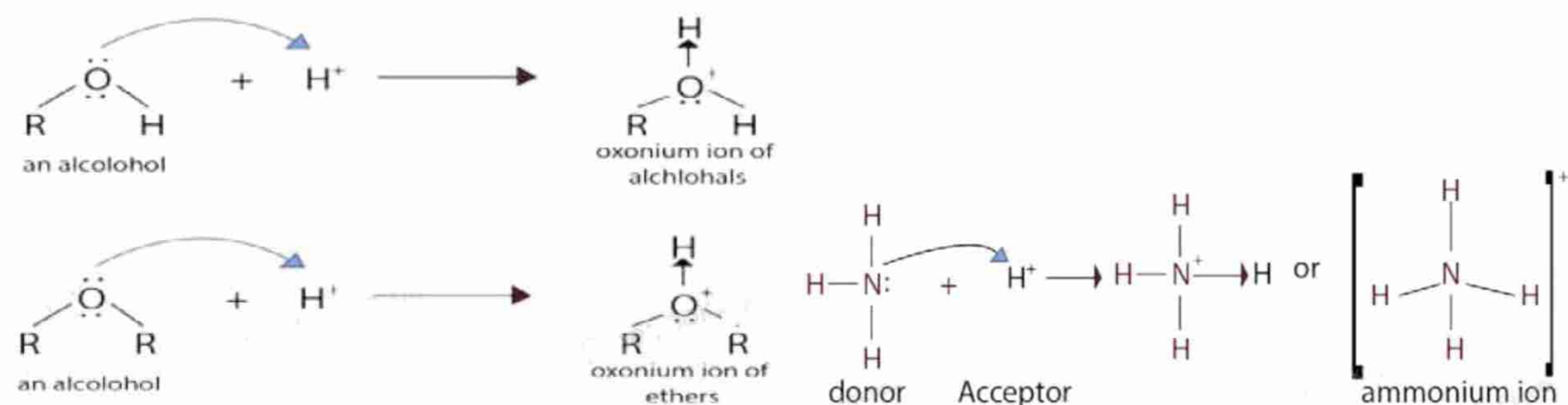

Valence Shell Electron Pair Repulsion Theory

(Prepare for Short Questions and Long Question)

Sidgwick and Powell (1940) **Nylholm and Gillespie** developed VSEPR theory.

Q. What is the basic assumption of VSEPR Theory?

The valence electron pairs (lone pairs and the bond pairs) are arranged around the central atom to remain at a maximum distance apart to keep repulsions at a minimum.

Q. Give any two postulates of VSEPR theory.

- (i) Both the lone pairs as well as the bond pairs participate in determining the geometry of the molecules.
- (ii) The electron pairs are arranged around the central polyvalent atom so as to remain at a maximum distance apart to avoid repulsions.
- (iii) The triple bond and double bond behave as single bond in geometry determination of the molecule.

Q. Why the electrons of lone pair occupy more space than bond pairs? (Also a postulate of VSEPR Theory)

A **bonding electron pair** is attracted by both nuclei of atoms while **non-bonding** by only one nucleus. Because a **lone pair experiences less nuclear attraction**, its electronic charge is spread out more in space than that for bonding pair. As a result, the **non-bonding electron pairs exert greater repulsive forces on bonding electron pairs** and thus tend to compress the bond pairs.

Q. What is the magnitude of repulsions between the electron pairs in a molecule? (Also a postulate of VSEPR Theory)

Lone pair- lone pair > lone pair -bond pair > bond pair - bond pair

Shapes of Molecules According to VSEPR

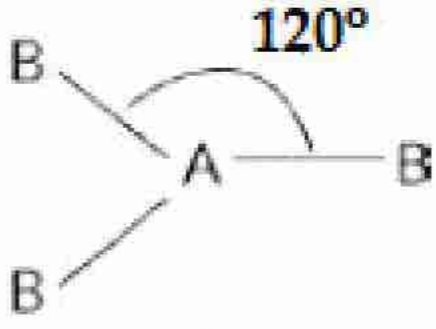
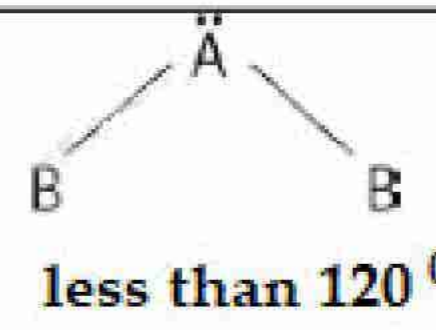
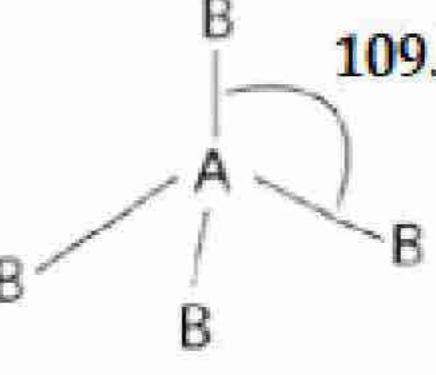
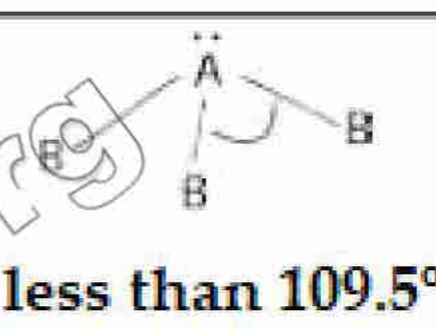
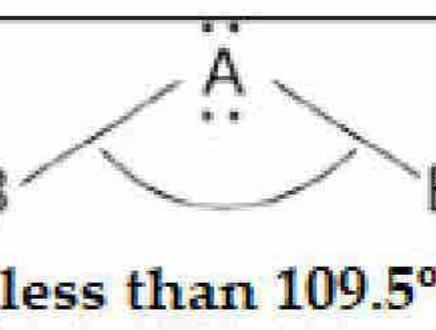
Type	Electron Pairs			Arrangement of pairs	Molecular geometry	Shape	Example	
	Total	Bonding	Lone					
AB ₂	2	2	0	Linear	Linear	B-A-B	BeCl ₂ HgCl ₂	
AB ₃	3	3	0	Trigonal planar	Trigonal planar		BH ₃ , BF ₃ AlCl ₃	
		2	1			Bent (or angular)		SnCl ₂ , SO ₂
AB ₄	4	4	0	Tetrahedral	Tetrahedral		CH ₄ , SiCl ₄ , CCl ₄ , BF ₄ , NH ₄ ⁺ , SO ₄ ²⁻	
		3	1			Trigonal pyramidal		NH ₃ , NF ₃ , PH ₃
		2	2			Bent (or angular)		H ₂ O, H ₂ S

Valence Bond Theory

(Learn for Short Questions and Long Question)

Q. Write two points of Valence Bond Theory.

According to valence bond theory:

- The partially filled atomic orbitals overlap to form bonds but the individual character of atomic orbitals is retained.
- Greater the overlap, stronger will be the bond formed.

Formation of Hydrogen molecule

As the two atoms of hydrogen approach each other, their 1s orbitals overlap, thereby giving the H-H bond. The electron density becomes concentrated between the two nuclei. The bond is called a sigma (σ) bond.

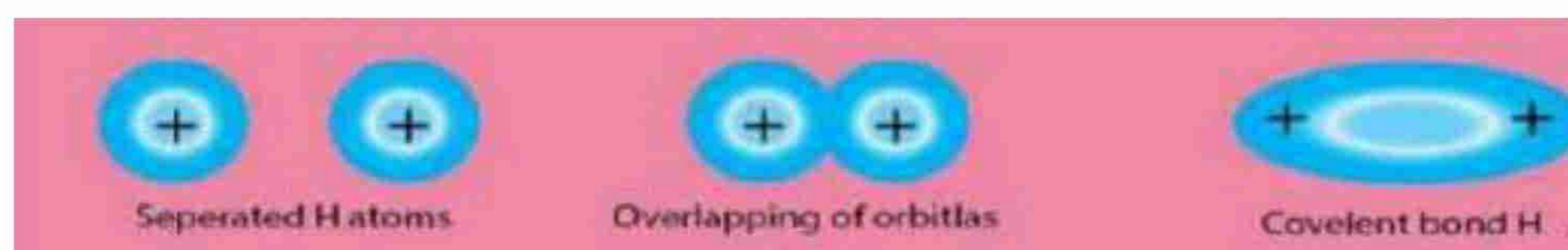

Formation of Hydrogen Fluoride molecule

The H-F bond is formed by the pairing of electrons - one from hydrogen and one from fluorine.

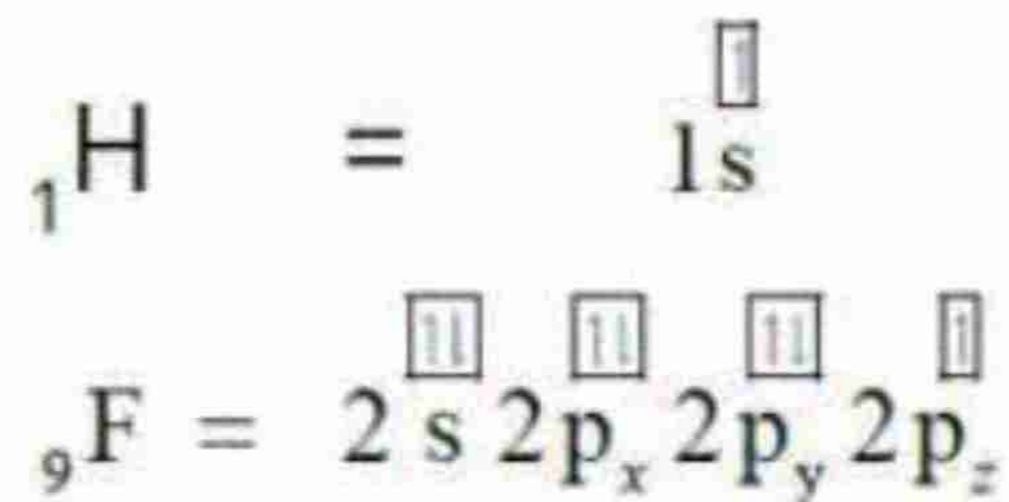

The fluorine atom completes its 2p sub-shell by acquiring a share of an electron from hydrogen.

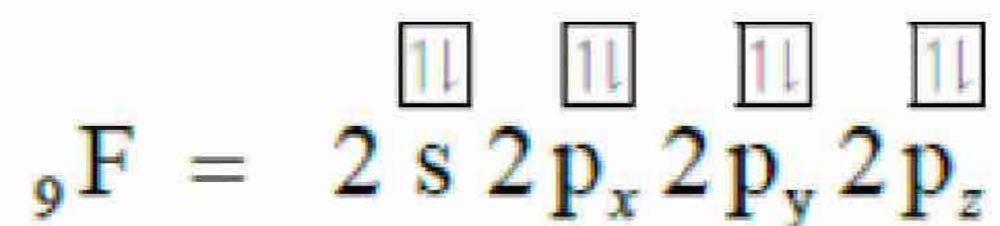

There are then two orbitals plus two electrons whose spins can adjust so they are paired.

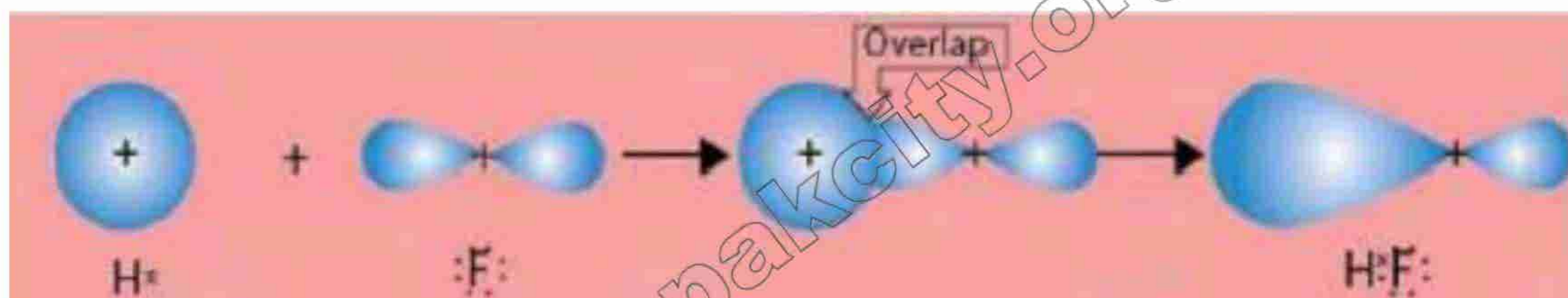

Formation of Fluorine molecule

The sigma bond in the fluorine molecule, F_2 is formed by the overlap of half-filled $2p_z$ orbital on each fluorine atom.



Formation of Nitrogen molecule

Nitrogen atoms have the following electronic configuration:



One end-to-end p orbital overlap occurs resulting in a sigma bond, the other two p orbitals are aligned parallel to the corresponding orbital in the other atom giving two pi bonds.

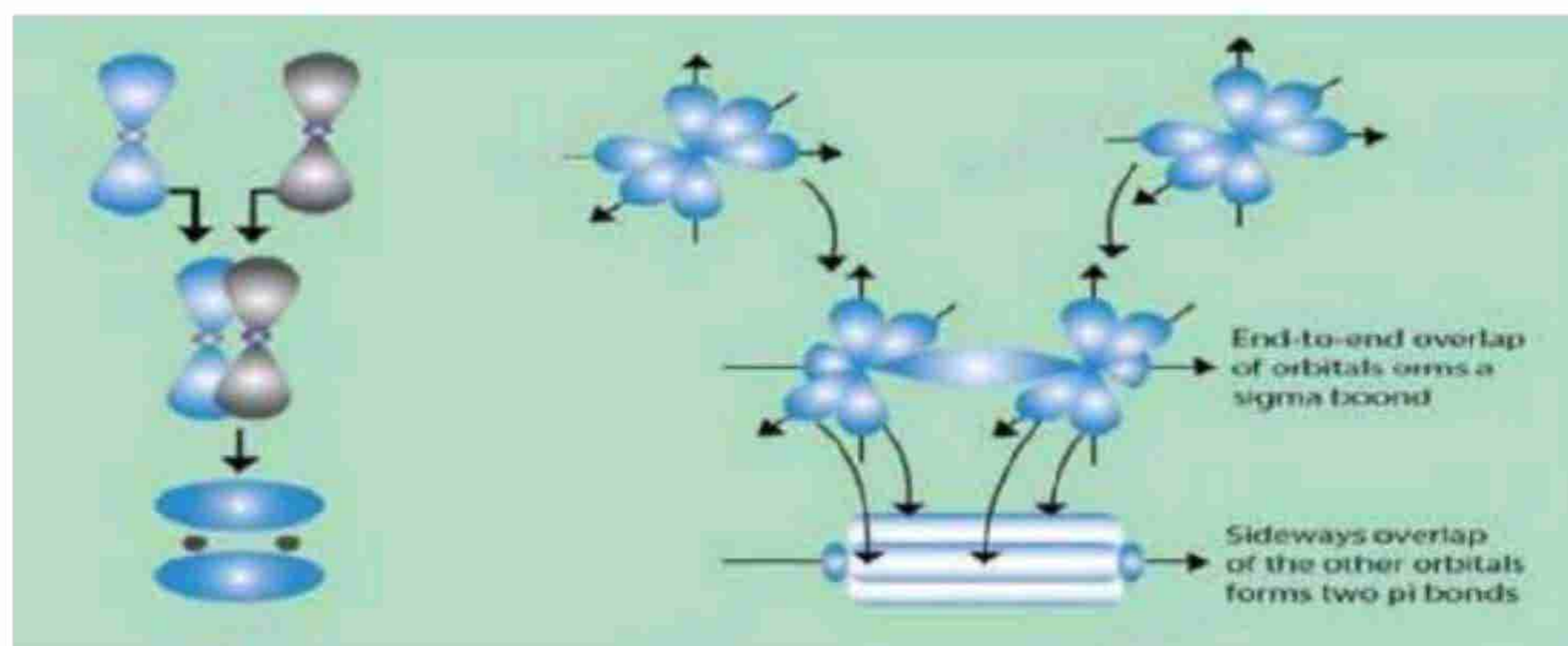

Formation of hydrogen sulphide molecule

H₂S is a non-linear molecule, and the bond angle between the two H-S bonds is about 92°. Each two 3p orbitals of sulphur containing one electron can overlap with the 1s orbitals of hydrogen atoms.

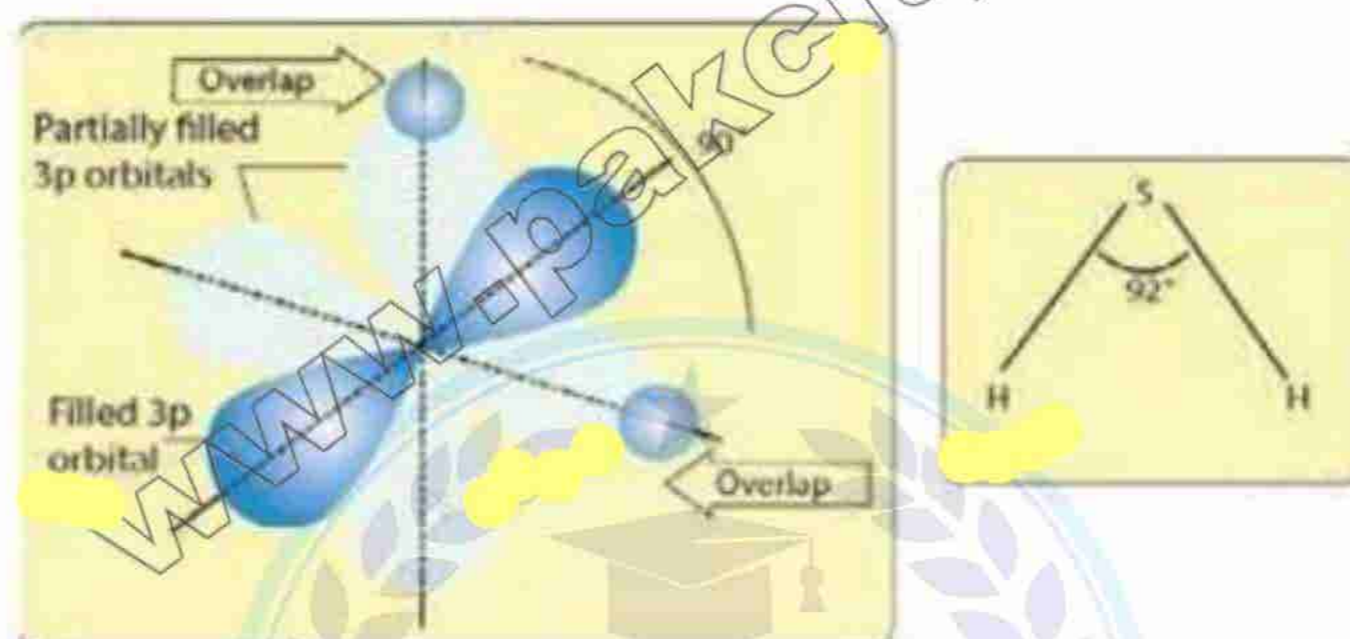
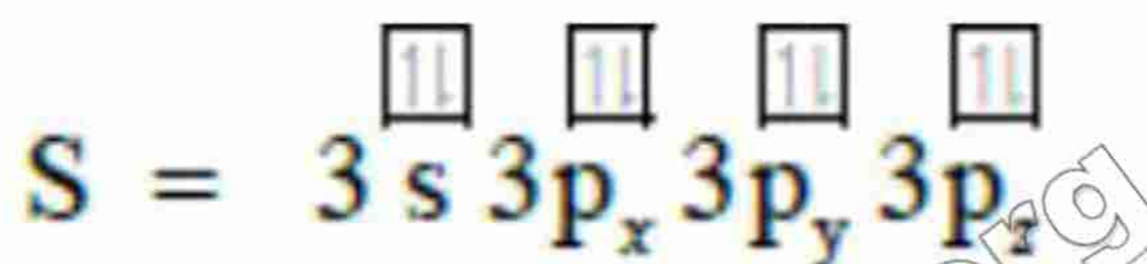

Q. Define sigma bond and pi bond.

A sigma bond is formed when two partially filled atomic orbitals overlap in such a way that the probability of finding the electron is maximum around the line joining the two nuclei.

A pi-bond is formed by the sideways overlap of two half-filled co-planar p-orbitals in such a way that the probability of finding the electron is above or below the line joining the two nuclei.

Q. Why pi bond is more diffused than sigma bond?

In sigma bond the electron density is between two nuclei. In pi bond electronic cloud lies above and below the line joining the nuclei, so pi bonds are more diffused (spread) than sigma bonds.

Hybridization

Atomic orbitals differing slightly in energy intermix to form new orbitals of exactly same shape and energy.

sp³ hybridization

One s and three p orbitals intermix to form a set of four equivalent sp^3 hybrid orbitals.

Methane

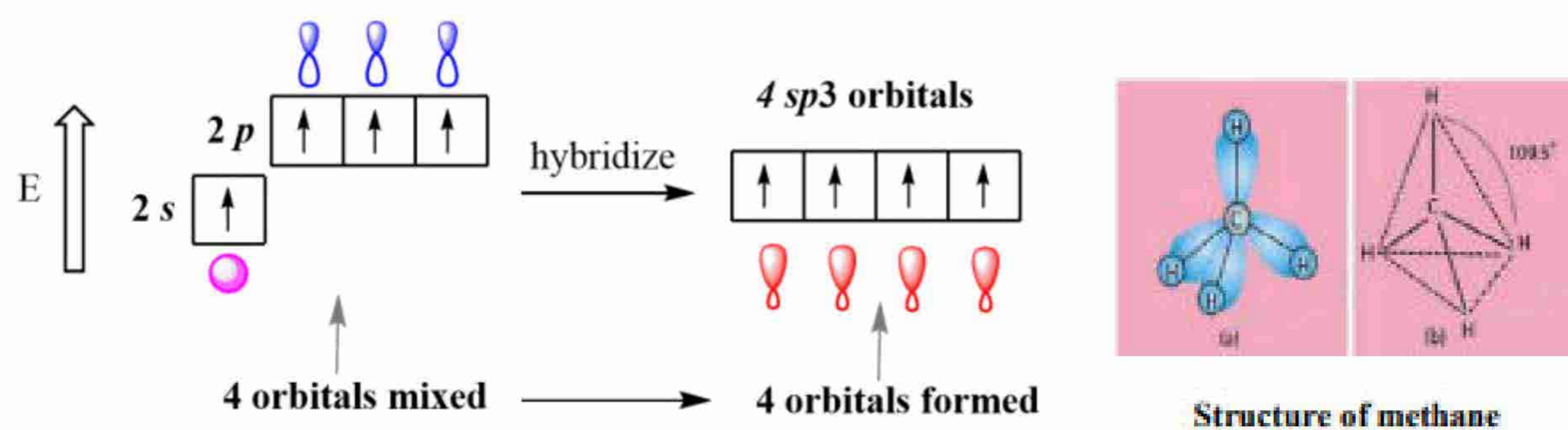

Overlap of orbitals: The two tetrahedrons of each carbon are joined together by sp^3 - sp^3 sigma bond. The other three sp^3 orbitals of each carbon overlap with s orbital of each hydrogen to form sp^3 -s sigma bonds.

Geometry: Each carbon is hybridized to give a tetrahedron.

Total bonds: One sp^3 - sp^3 sigma bond and six sp^3 -s sigma bonds.

Bond angles: Bond angle in each tetrahedron is 109.5° .

Ammonia

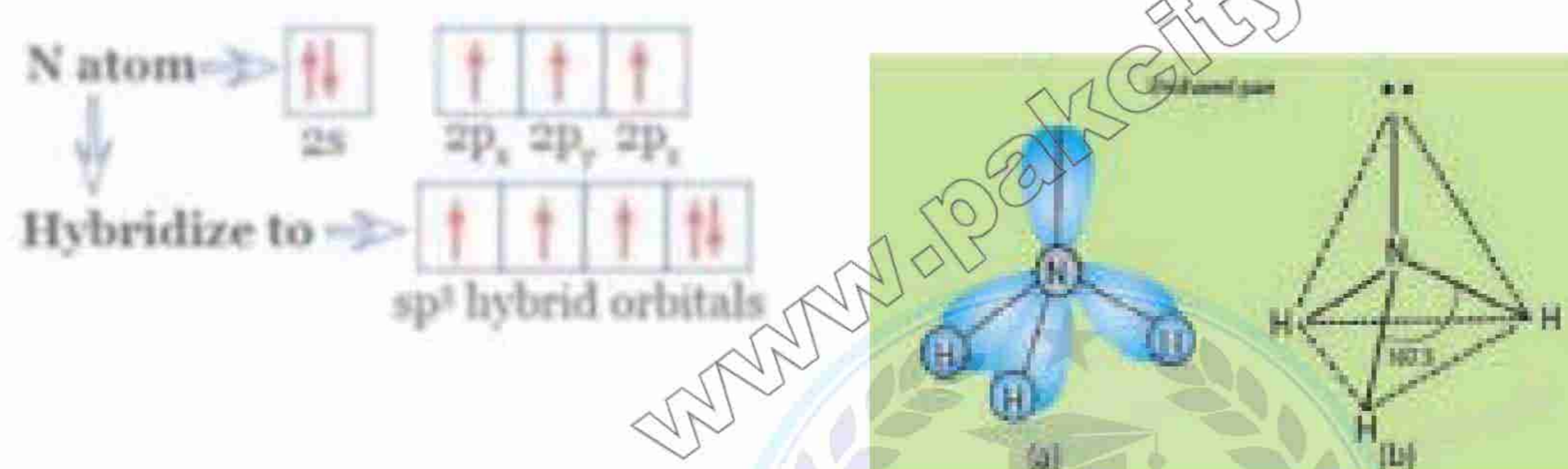

Overlap of orbitals: Three sp^3 orbitals overlap with three s-orbitals of hydrogen atoms.

Geometry: One corner of the tetrahedron is occupied by lone pair of electrons. The other three corners have single electron. Shape of ammonia is a pyramidal molecule due to repulsion of bond pairs by lone pair of electrons.

Total bonds: Three sigma bonds formed by sp^3 -s orbital overlap.

Bond angle: The bond angle in ammonia is 107.5°

Water

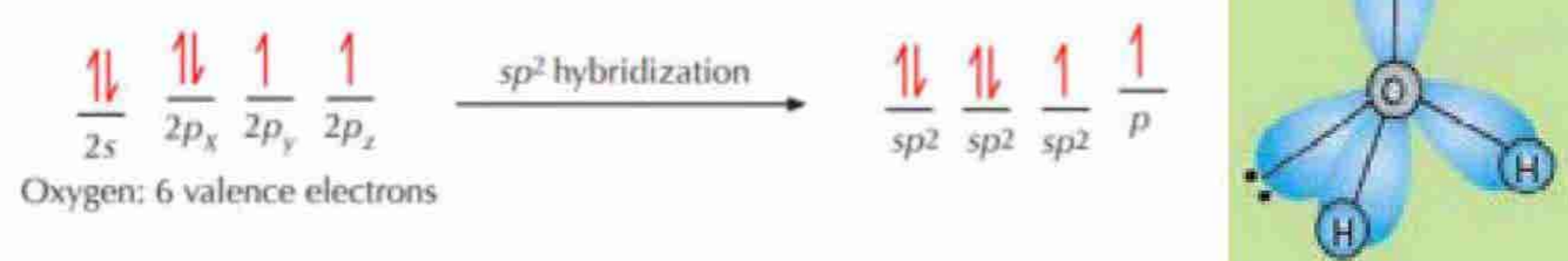

Overlap of orbitals: The sp^3 orbitals overlap with s orbital of H atoms to form two sigma bonds. **Geometry:** The hybrid orbitals will have a tetrahedral arrangement. The two corners of the tetrahedron are occupied by lone pair of electrons and the other two corners by single electron. The molecule of water has bent or angular structure (distorted tetrahedron) because of the repulsion of lone pairs on bond pairs.

Total bonds: Two sigma bonds formed by sp^3 -s orbital overlap.

Bond angle: The bond angle in water is 104.5°

sp^2 hybridization

In sp^2 hybridization, one 's' and two 'p' atomic orbitals of an atom intermix to form three orbitals called sp^2 hybrid orbitals.

Boron Trifluoride

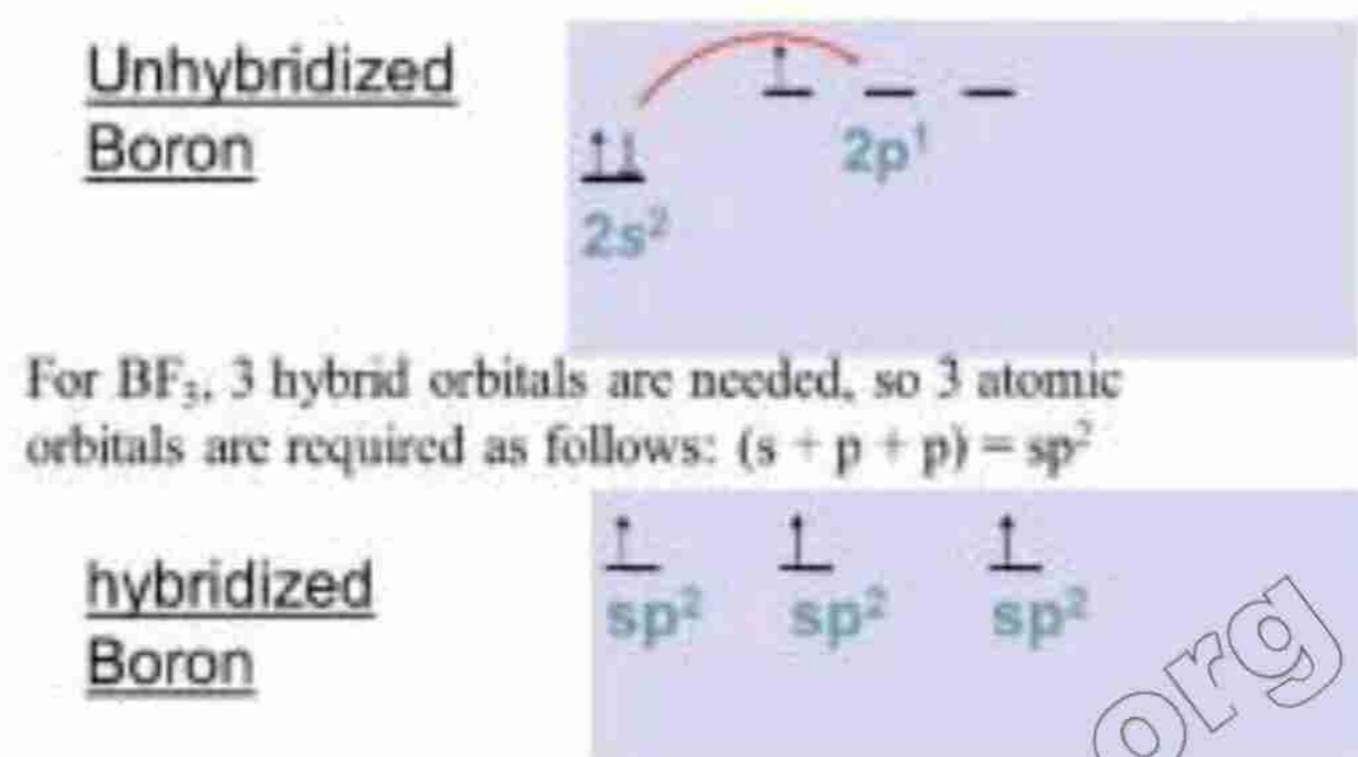

Overlap of orbitals: BF_3 is formed by the overlap of three half-filled sp^2 hybrid orbitals of boron with $2p_z$ orbitals of three fluorine atoms.

Geometry: The structure is triangular planar.

Total bonds: Three bonds formed by sp^2 - $2p_z$ orbital overlap.

Bond angle: The three bond angles are each of 120° .



Ethene/Ethylene

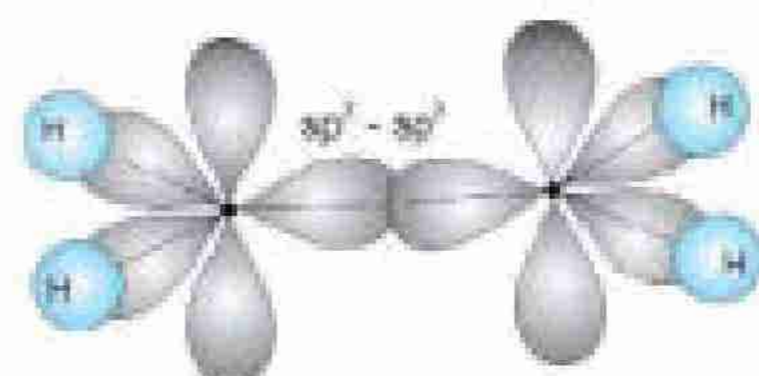
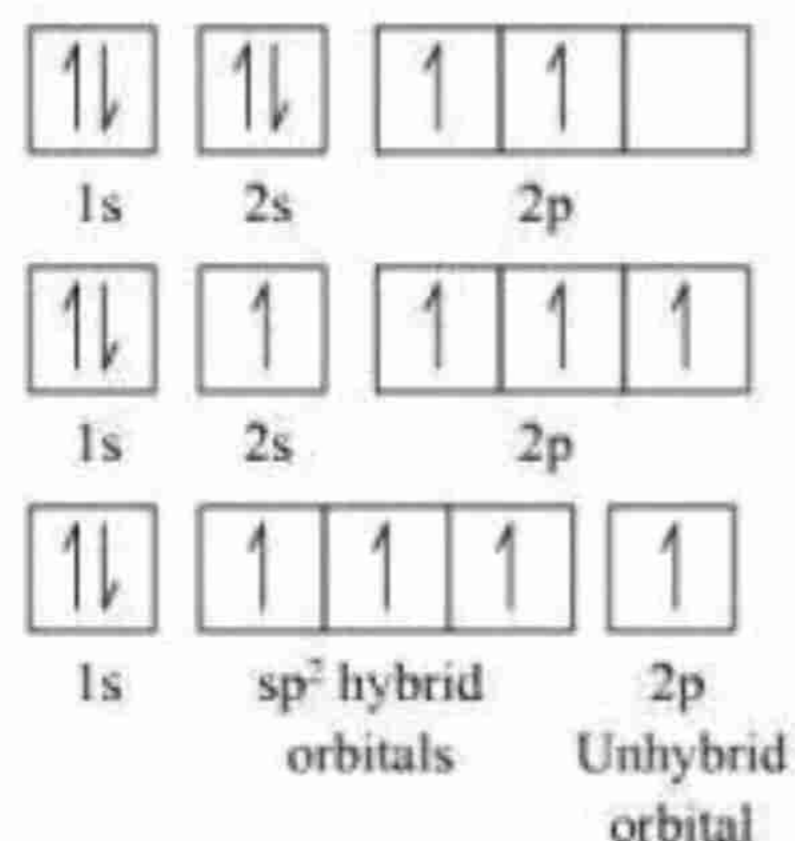

Overlap of orbitals: sp^2 hybrid orbital of each carbon overlaps to give sp^2-sp^2 sigma bond and the other two sp^2 orbitals overlap with 1s orbitals of hydrogen to give sp^2-s sigma bonds. The unhybridized 2p orbitals overlap sideways to give a π -bond.

Geometry: Trigonal planar.

Bond angle: The bond angle between any two sp^2 hybrid orbitals is 120° .

sp hybridization

In sp hybridization, one 's' and one 'p' orbitals intermix to form two sp-hybrid orbitals.

Beryllium dichloride

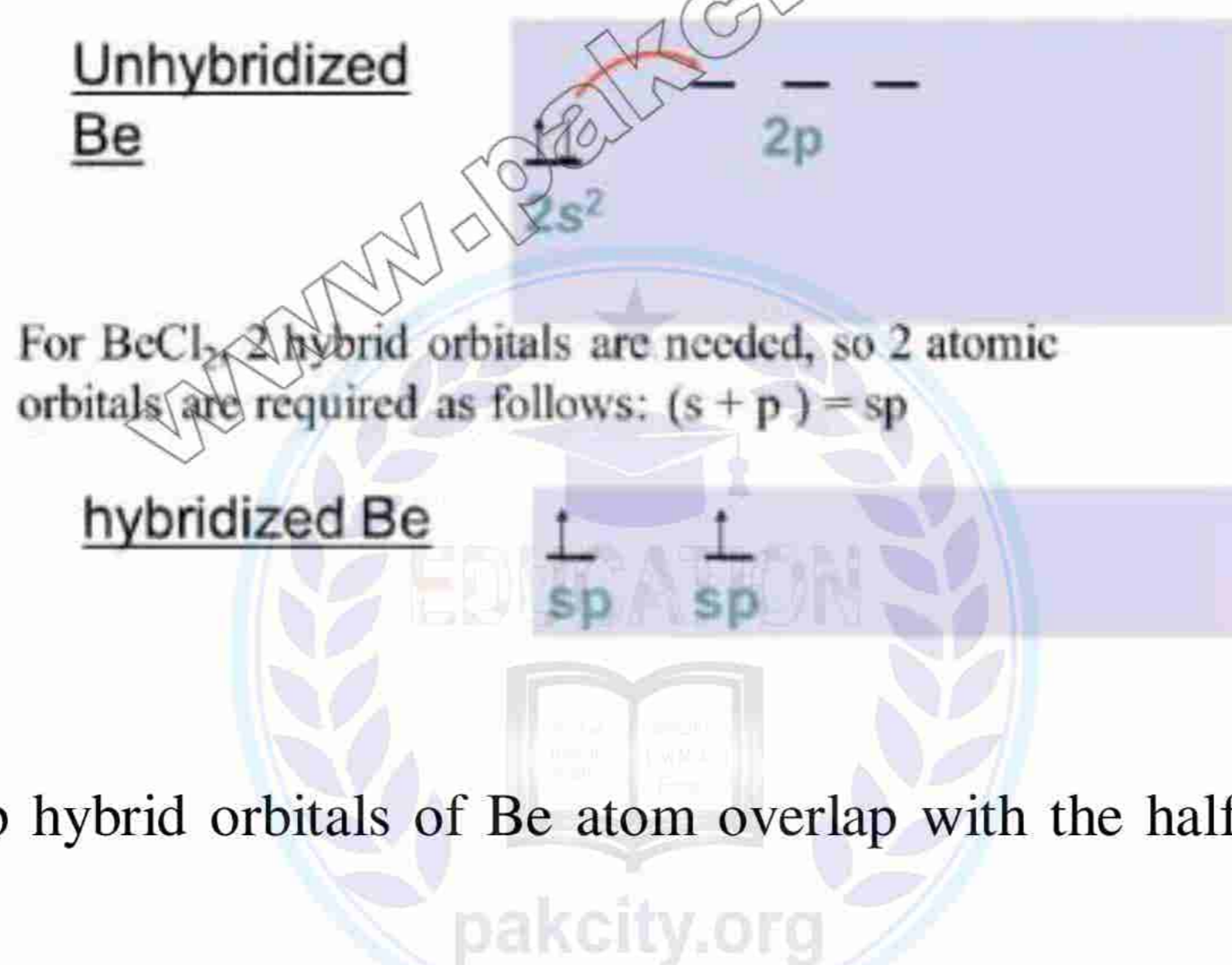

Overlap of orbitals: Two sp hybrid orbitals of Be atom overlap with the half-filled 3p orbitals of chlorine atoms.

Geometry: Linear shape.

Total bonds: Two sp-3p sigma bonds.

Bond angle: The Cl-Be-Cl bond angle is 180° .

Ethyne/Acetylene

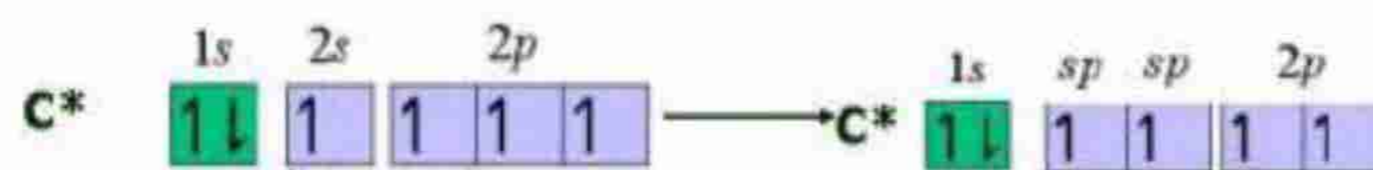

In sp hybridization, there are still two unhybridized 2p orbital

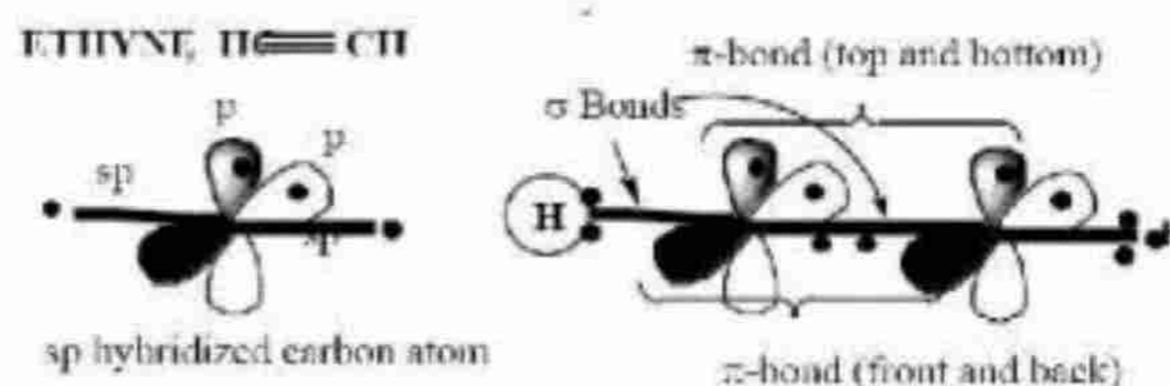

Overlap of orbitals: Two sp hybridized carbon atoms join together to form a sigma bond by sp-sp overlap. The other sp orbital forms a sigma bond with 1s orbital of hydrogen atom. The two unhybridized p orbitals on each carbon atom overlap sideways give two π -bonds.

Geometry: Linear shape.

Total bonds: One sp-sp sigma bond and two sp-s sigma bonds. Two, $2p_y$ - $2p_y$ and $2p_z$ - $2p_z$, π -bonds.

Bond angles: These orbitals have a bond angle of 180° .

Q. The bond angles of H_2O and NH_3 are not 109.5° like that of CH_4 although Oxygen and Nitrogen atoms are sp^3 hybridized. Why?

- H_2O has two lone pairs, so it repels the bond pairs much more and makes bond angle shorter till 104.5° .
- NH_3 has one lone pair that repels the three bond pairs so the bond angle between hydrogen atoms of ammonia is 107.5° .
- CH_4 molecule has no lone pair, and each bond pair repels each other with equal force and bond angle between two adjacent hydrogen atoms becomes 109.5° .

Molecular Orbital Theory



(Learn for Short Questions and Long Question)

Q. What is the difference between VBT and MOT?

Following are the points of difference between VBT and MOT:

1. **VBT considers overlap of valence shells** whereas **MOT considers atoms as a whole** to participate in bonding.
2. Simplest **diagrammatic** representation of **no bond formation** was given by **MOT** not VBT.
3. **MOT** very well **explains the paramagnetism and diamagnetism** phenomena in molecules whereas VBT fails to explain it.
4. **Simplest formula to calculate bond order** was given by **MOT** not VBT.

Q. Define bond order.

The number of bonds formed between two atoms after the atomic orbitals overlap is called the bond order and is taken as half of the difference between the number of bonding electrons and anti-bonding electrons. The number of bonds formed between H-atoms in hydrogen molecule may be calculated as follows:

Number of electrons in the bonding orbitals = 2

Number of electrons in the anti-bonding orbitals = 2

Bond order

$$= \frac{2-0}{2} = 1$$

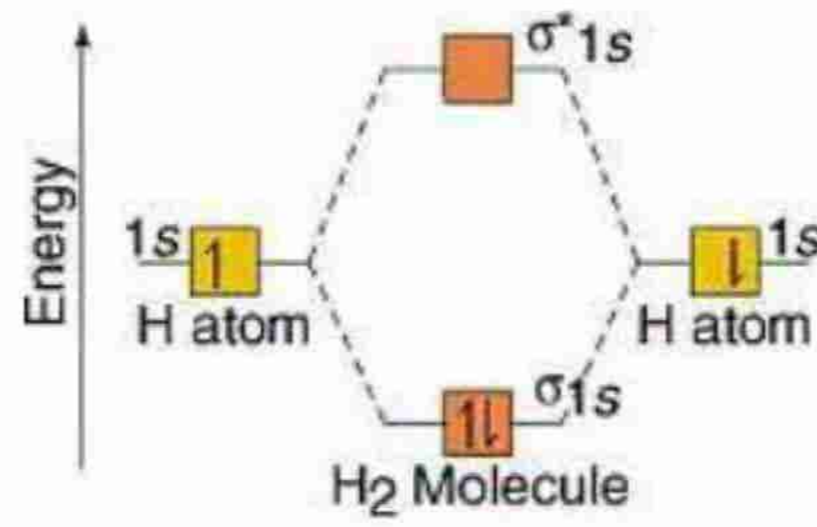

MOT Diagrams of He, N₂ and O₂

Helium

Nitrogen (diamagnetic repelled by magnetic field)

$$\frac{2-2}{2} = 0$$

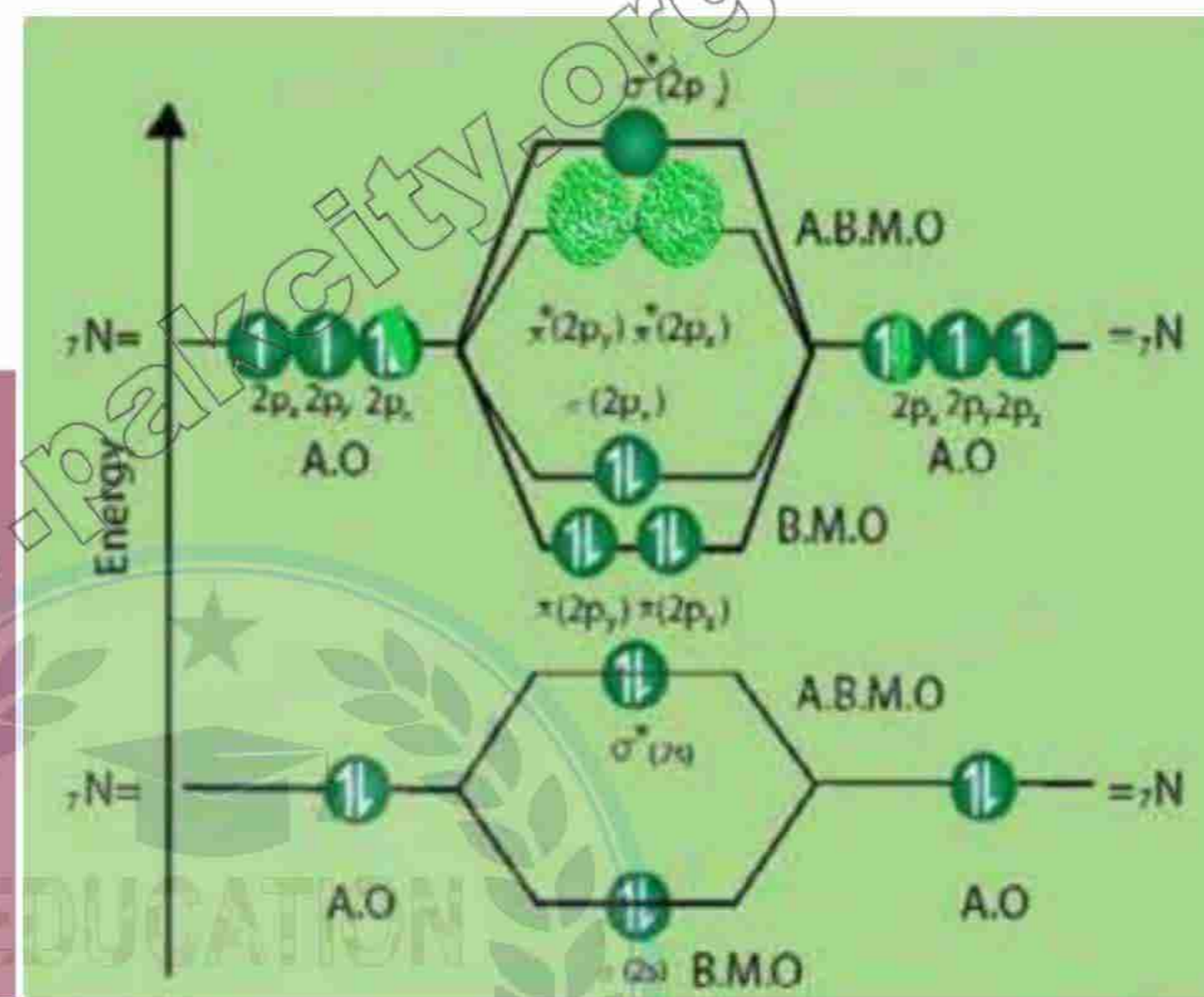
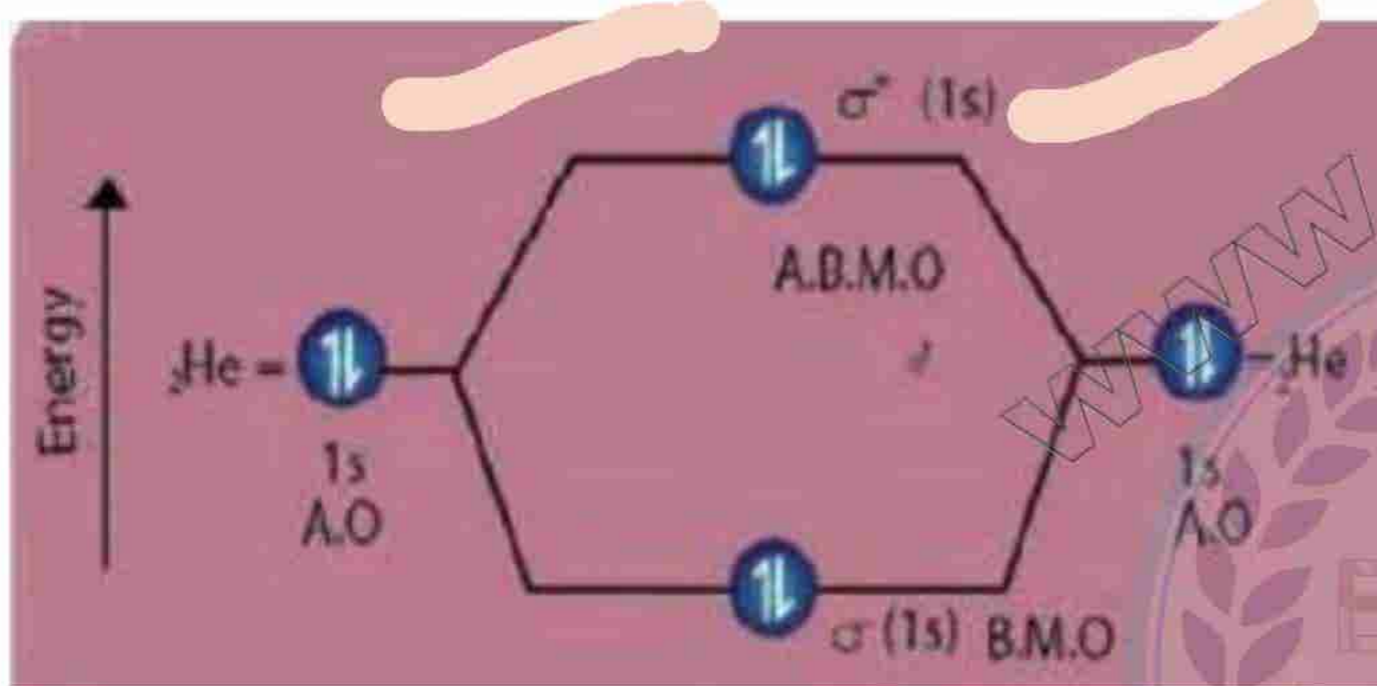

$$\sigma(1s^2) < \sigma^*(1s^2) < \sigma(2s^2) < \sigma^*(2s^2) < \pi(2p^2) = \pi(2p^2) < \sigma(2p^2) < \pi^*(2p_y) = \pi^*(2p_z) < \sigma^*(2p_x)$$

$$\frac{6-0}{2} = \frac{6}{2} = 3$$

Oxygen (paramagnetic gets attracted by magnetic field in liquid state)

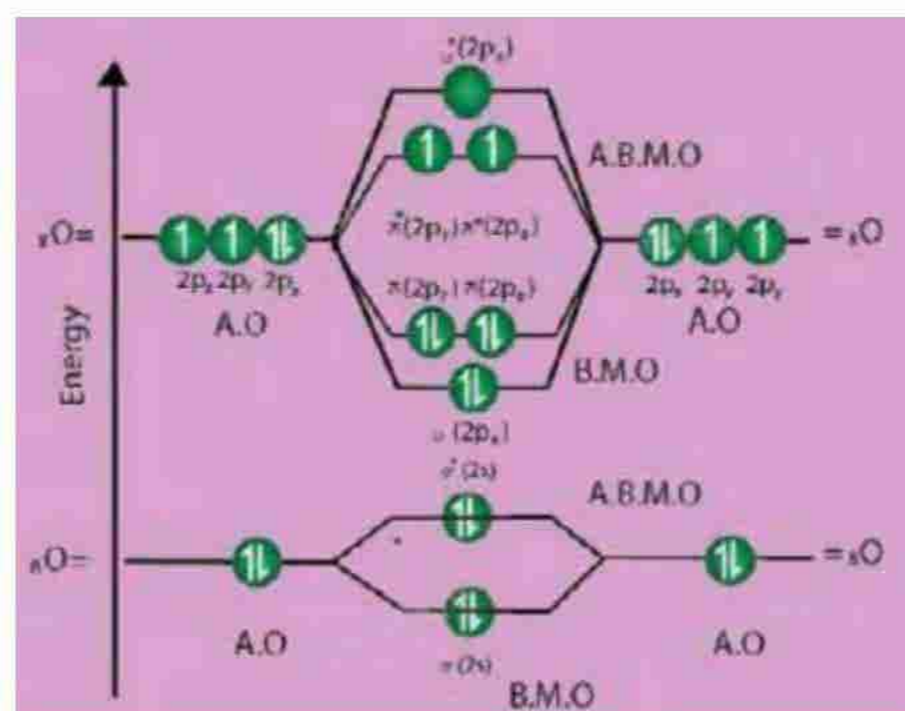

$$\sigma(1s)^2 < \sigma^*(1s)^2 < \sigma(2s)^2 < \sigma^*(2s)^2 < \sigma(2p_x) < \pi(2p_y)^2 = \pi(2p_z)^2 < \pi^*(2p_y)^1 = \pi^*(2p_z)^1 < \sigma^*(2p_x)$$

$$\frac{6-2}{2} = 2$$

Q. Why the energy of anti-bonding molecular orbital is higher than corresponding bonding molecular orbital?

Anti-bonding orbitals are higher in energy because there is **less electron density between the two nuclei**. An anti-bonding orbital is formed when **overlap between atomic orbitals results in destructive interference**. Thus, when the **electrons in an anti-bonding orbital spend less time between the two nuclei**, they are at a higher energy level.

Bond Energy, Bond Length and Dipole Moment

Q. On what factors bond strength depends?

- i. Electronegativity ii. Size of atom iii. Bond length

Some Important Molecules Asked for Comparison

Molecule	Geometry	Dipole Moment
SO ₂ (polar)	Angular	1.61 D
BF ₃ (non-polar)	Symmetrical triangular planar	0 D
CO ₂	Linear	0 D
CO	Linear with permanent pole	0.12 D
SO ₃	Trigonal	0 D

The Effect of Bonding on the Properties of Compounds

Ionic bonds are non-directional, whereas, **covalent bonds are directional** resulting in isomerism.

Compounds show solubility on the basis of “**like dissolves like**”.

Q. Why the melting points, boiling points, heats of sublimation and heats of vaporization of electrovalent compounds are higher as compared with those of covalent compounds?

Electrovalent compounds are made of oppositely charged ions so they have high melting point, boiling point, heat of sublimation and heat of vapourization as compared to covalent bonds formed by orbital overlap.

Chapter 7

Thermochemistry

Q. Define thermochemistry.

The study of **heat changes accompanying a chemical reaction** is known as thermochemistry.

Q. What is thermochemical equation? What information do they convey? Give two examples.

A balanced chemical equation which shows not only the reactants and products but also the amount of heat energy absorbed or released is known as a thermochemical equation.

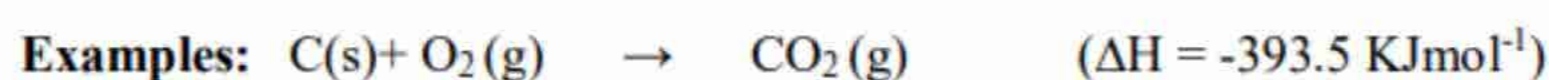

The important information that can be drawn from thermochemical equations is:

Nature of reaction is predicted, whether it is endothermic or exothermic.

Exact amount of net heat released or absorbed in the reaction.

Q. What is the difference between endothermic and exothermic reactions?



Sr No	Exothermic reactions	Endothermic reactions
1	In this reaction reactants are at higher energy in the beginning of a reaction and products obtained are at lower energy after reaction. The difference in the energy of products and reactants appears in the form of heat released by the system in the surroundings.	In this reaction reactants are at lower energy before reaction starts and products obtained are at higher energy after reaction stops. The difference in the energy of products and reactants appears in the form of heat absorbed by the system from the surroundings.
2	The reactions in which heat energy is evolved	The reactions in which heat energy is absorbed
3	The enthalpy change is shown with a negative sign	The enthalpy change is shown with a positive sign
4	Example $\text{C (s)} + \text{O}_2 \text{ (g)} \longrightarrow \text{CO}_2 \text{ (g)} \quad \Delta H = -393.7 \text{ kJ/mol}$	Example $\text{N}_2 \text{ (g)} + \text{O}_2 \text{ (g)} \longrightarrow 2\text{NO (g)} \quad \Delta H = +180.51 \text{ kJ/mol}$

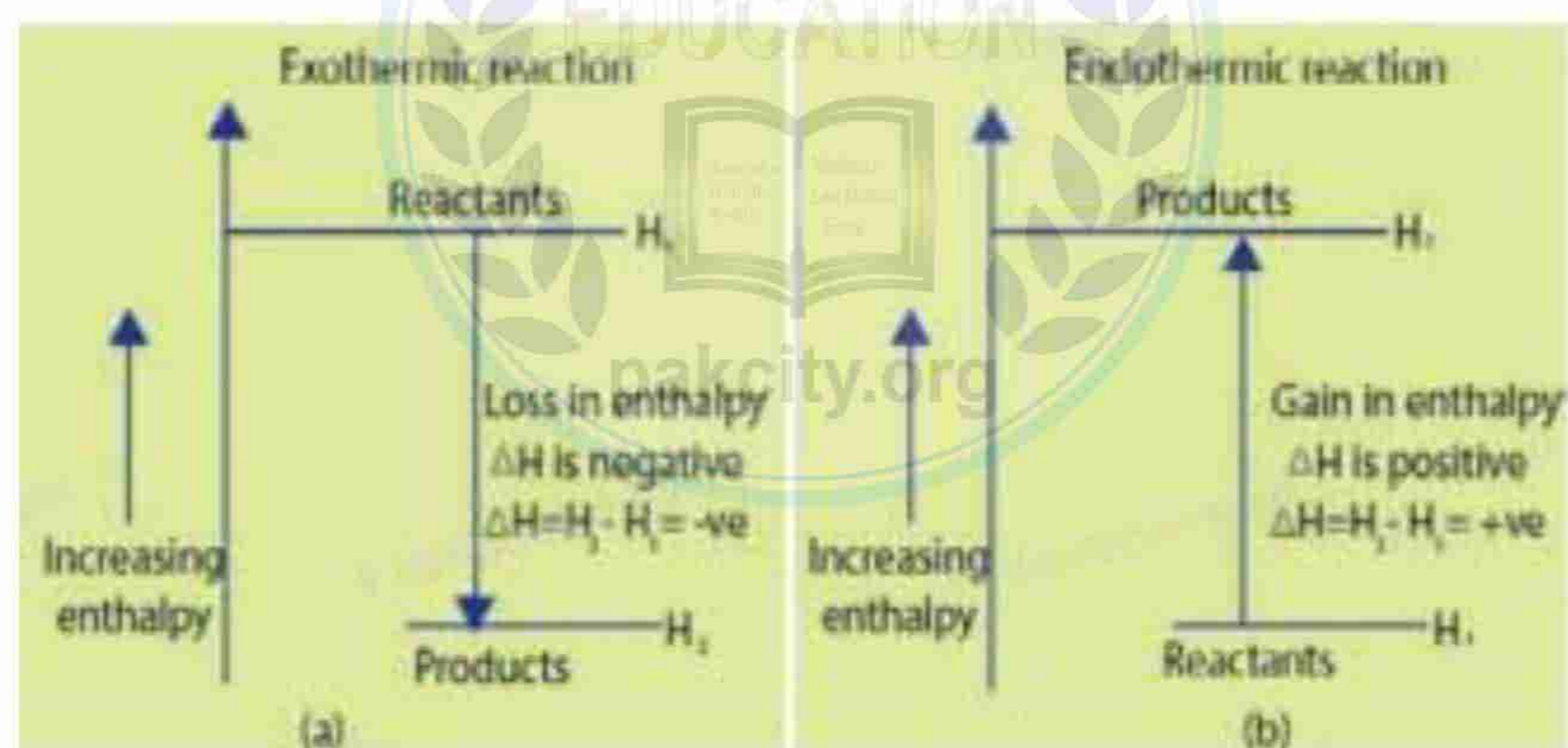

System, Surrounding and State Function

Q. Define system, surrounding, boundary, state and state function.

System

The term system is used for **anything (materials) under test in the laboratory or under consideration in the classroom** for the purpose of argument.

Surrounding

The **remaining portion of the universe other than the system** is known as its surroundings.

Boundary

The **real or imaginary surface separating the system from the surroundings** is called the

State

The state of a system is the **condition of a system**.

Example: Initial temperature T_1 and final temperature T_2 .

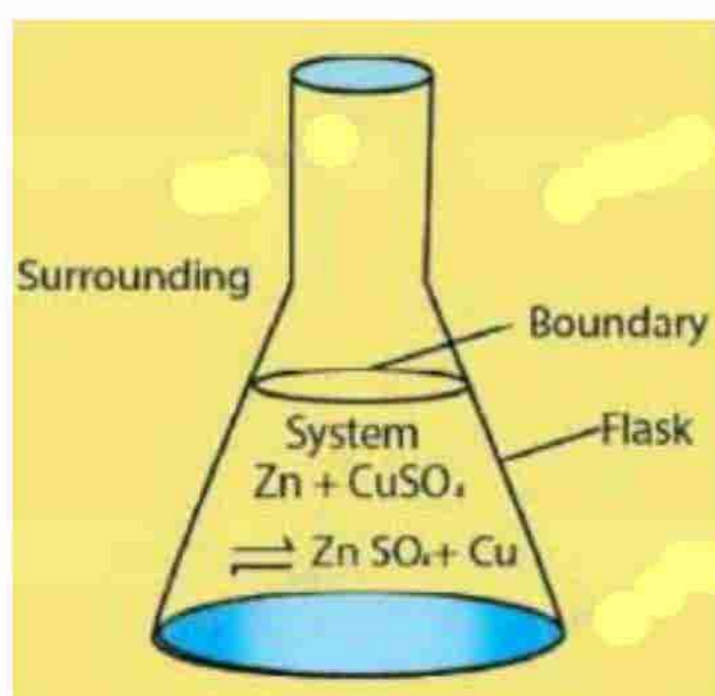
**State Function**

A state function is a **macroscopic property** of a system which has some **definite values** for **initial and final states** and which is **independent of the path adopted** to bring about a change. By convention, we use capital letters as symbols for a state function, e.g. **pressure (P), temperature (T), volume (V), internal energy (E) and enthalpy (H)** are all state functions.

Spontaneous and Non-Spontaneous Reactions

Q. What is the difference between a spontaneous and a non-spontaneous reaction?

A process which **takes place on its own without any outside assistance** is termed as spontaneous process. It is **unidirectional, irreversible and a real process**.

Examples

- (i) Water flows from higher level to the lower level. The flow cannot be reversed without some external aid.
- (ii) Neutralization of a strong acid with a strong base is a spontaneous acid-base reaction.



Non-spontaneous does not take place on its own and does not occur in nature. It is bidirectional and reversible.

Examples

- (i) Pumping of water uphill.
- (ii) Transfer of heat from cold interior part of the refrigerator to the hot surroundings.
- (iii) When nitrogen reacts with oxygen, nitric oxide is formed. The reaction takes place when the energy is provided by lightening.

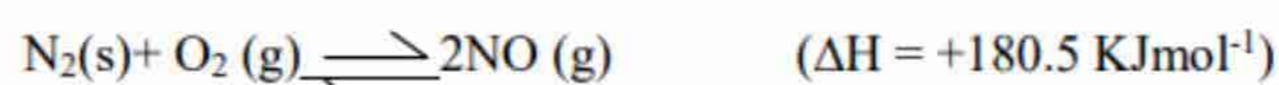

Q. Burning of candle is a spontaneous process. Justify.

Once a candle is lit it burns on its own without any constant supply of heat. That is why, it is a spontaneous process.

Internal Energy and First Law of Thermodynamics

(Learn for Short Questions and Long Question)

Q. What is internal energy of a system?

The **total** of all the possible kinds of energies of the system i.e **kinetic energy and potential energy** is called its internal energy, **E**.

Mathematically

$$E = \Sigma \text{ kinetic energy} + \Sigma \text{ potential energy}$$

Q. State first law of thermodynamics.

The first law of thermodynamics, also called the **law of conservation of energy**, states that **energy can neither be created nor destroyed, but can be changed from one form to another.**

Q. Define heat and work.

(Both NOT state function)

Heat is the **quantity of energy that flows across the boundary of a system during a change in its state due to the difference in temperature between the system and the surroundings.** Represented by 'q'. The sign of **q** is **positive** when **heat is absorbed by the system** from surroundings and **q** is **negative** when **heat is absorbed by the surroundings** from the system.

Work is defined as the **product of force and distance** i.e.

$$W = F \times S$$

Work is measured in **Joules in SI units**.

The sign of **W** is **positive** when **work is done on the system** and **W** is **negative** when **work is done by the system**.

Q. Prove that $\Delta E = q_v$ and $\Delta E = q_p$

$$\Delta E = q_v$$

Consider a gas enclosed in a cylinder having a frictionless piston. When a quantity of heat q is supplied to the system, its internal energy E_1 changes to E_2 and piston moves upwards. The change in internal energy ΔE is given by the following equation:

$$\Delta E = E_2 - E_1 = q + w$$

$$\Delta E = q + w$$

If w is pressure-volume work then:

$$\Delta E = q - P\Delta V$$

If $\Delta V = 0$ then:

$$\Delta E = q_v$$

A change in internal energy of a system at constant volume is equal to heat absorbed by the system (q_v).

$$\Delta E = q_p$$

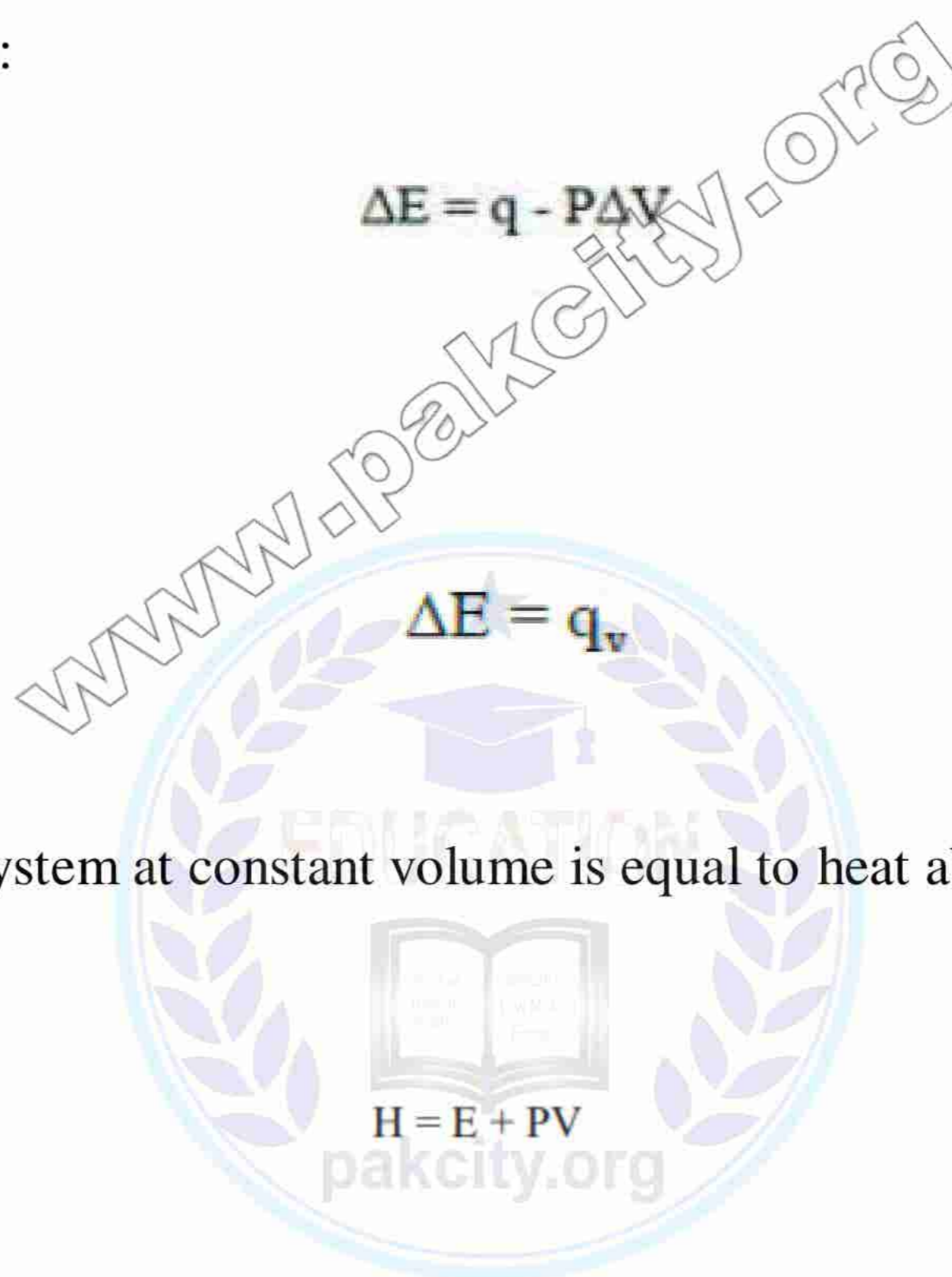

$$\Delta H = \Delta E + \Delta(PV)$$

$$\text{or } \Delta H = \Delta E + V\Delta P + P\Delta V$$

At $\Delta P = 0$

$$\Delta H = \Delta E + P\Delta V$$

Q. Define enthalpy.

Enthalpy is equal to the **internal energy E plus the product of pressure and volume (PV)**.

$$H = E + PV$$

Enthalpy is a **state function**. It is measured in **Joules**.

Q. Define enthalpy of a reaction, enthalpy of formation, enthalpy of atomization, enthalpy of neutralization, enthalpy of combustion and enthalpy of solution.

The **standard enthalpy of a reaction ΔH°** is the enthalpy change which occurs when the certain number of moles of reactants as indicated by the balanced chemical equation, react together completely to give the products under standard conditions, i.e. 25 °C (298K) and one atmosphere pressure. All the reactants and products must be in their standard physical states. Its units are kJ mol^{-1}

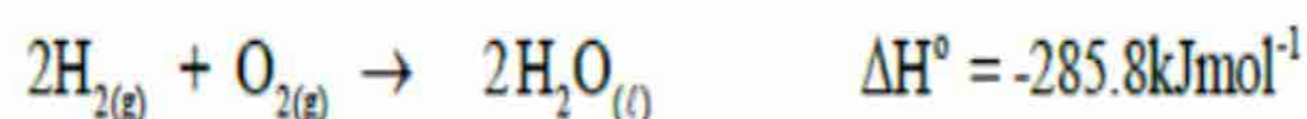

The **standard enthalpy of formation of a compound** is the amount of heat absorbed or evolved when one mole of the compound is formed from its elements. It is denoted by ΔH°_f . All the substances involved are in their standard physical states and the reaction is carried out under standard conditions i.e. at 25 °C (298 K) and one atm. pressure. Its units are kJ mol^{-1} .



The **standard enthalpy of atomization** of an element is defined as the amount of heat absorbed when one mole of gaseous atoms is formed from the element under standard conditions. It is denoted by ΔH°_{at} . For example, the standard enthalpy of atomization of hydrogen is given below:



The **standard enthalpy of neutralization** is the amount of heat evolved when one mole of hydrogen ions $[\text{H}^+]$ from an acid react with one mole of hydroxide ions $[\text{OH}^-]$ from a base to form one mole of water. For example, the enthalpy of neutralization of sodium hydroxide by hydrochloric acid is $-57.4 \text{ kJ mol}^{-1}$. A strong acid HCl and a strong base, NaOH, ionize completely in dilute solutions as follows:

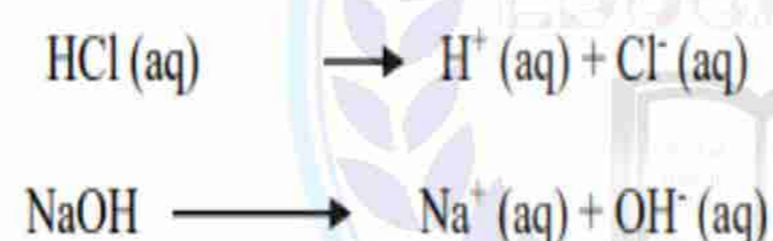

The **standard enthalpy of combustion** of the substance is the amount of heat evolved when one mole of the substance is completely burnt in excess of oxygen under standard conditions. It is denoted by ΔH°_c .

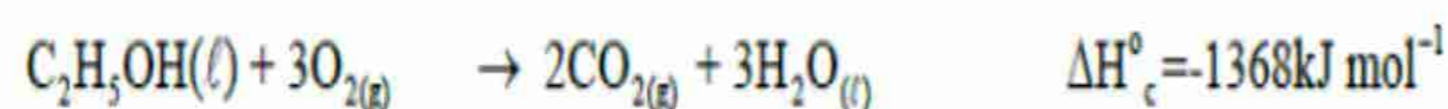

The **standard enthalpy of a solution** is the amount of heat absorbed or evolved when one mole of a substance is dissolved in so much solvent that further dilution results in no detectable heat change. For example, enthalpy of solution (ΔH°_{sol}) of ammonium chloride is $+16.2 \text{ kJ mol}^{-1}$ and that of sodium carbonate is $-25.0 \text{ kJ mol}^{-1}$.

Measurement of Enthalpy of a Reaction

(Learn for Short Questions and Long Question)

Q. How enthalpy of neutralization is determined?

The enthalpy of neutralization is determined by glass calorimeter.

Construction and Working of Glass Calorimeter

Reactants in **stoichiometric amounts** are placed in the calorimeter. When the reaction proceeds, the heat energy is evolved or absorbed. The temperature of the system is recorded before and after the chemical reaction. Knowing the temperature change, the mass of reactants present and the specific heat of water, we can calculate the quantity of heat q : $q = m \times s \times \Delta T$

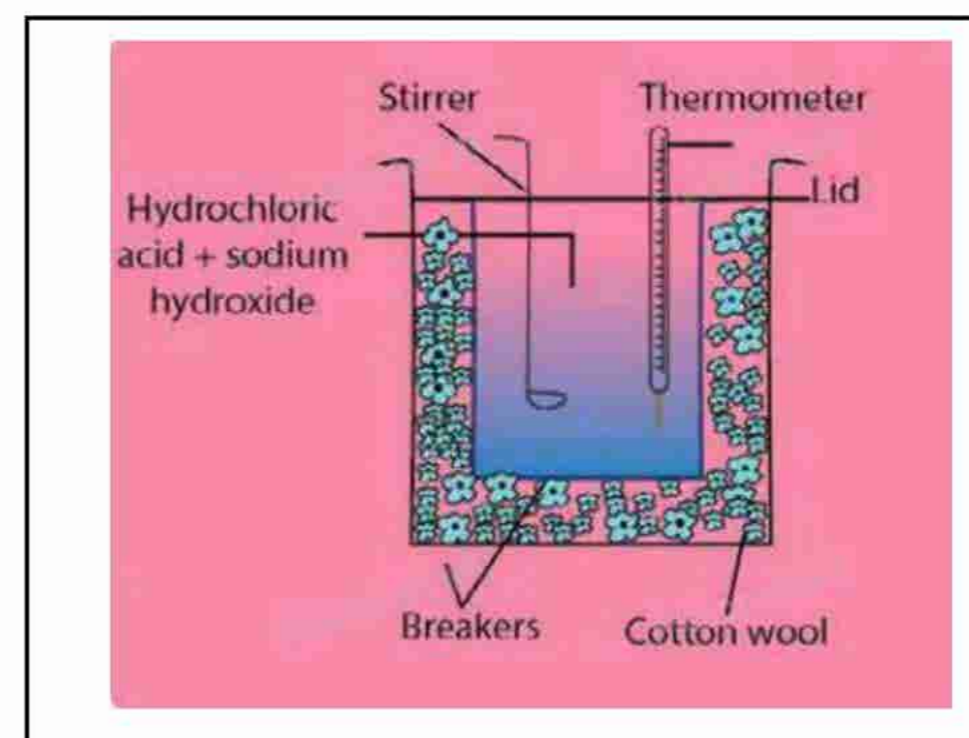

Construction and Working of Bomb Calorimeter

Q. What is the purpose of using bomb calorimeter?

A bomb calorimeter is usually used for the accurate determination of the enthalpy of combustion for food, fuel and other compounds.

Steel vessel lined with enamel. One gram substance placed in Platinum crucible inside the bomb. Oxygen up to 20 atm is filled and lid is screwed tightly. Bomb immersed in a known mass of water in calorimeter.

It is allowed to attain steady temperature. Ignition of substance done by current through coil. Temperature of water noted after 30 sec interval. Enthalpy of combustion calculated by:

$$q = c \times \Delta T$$

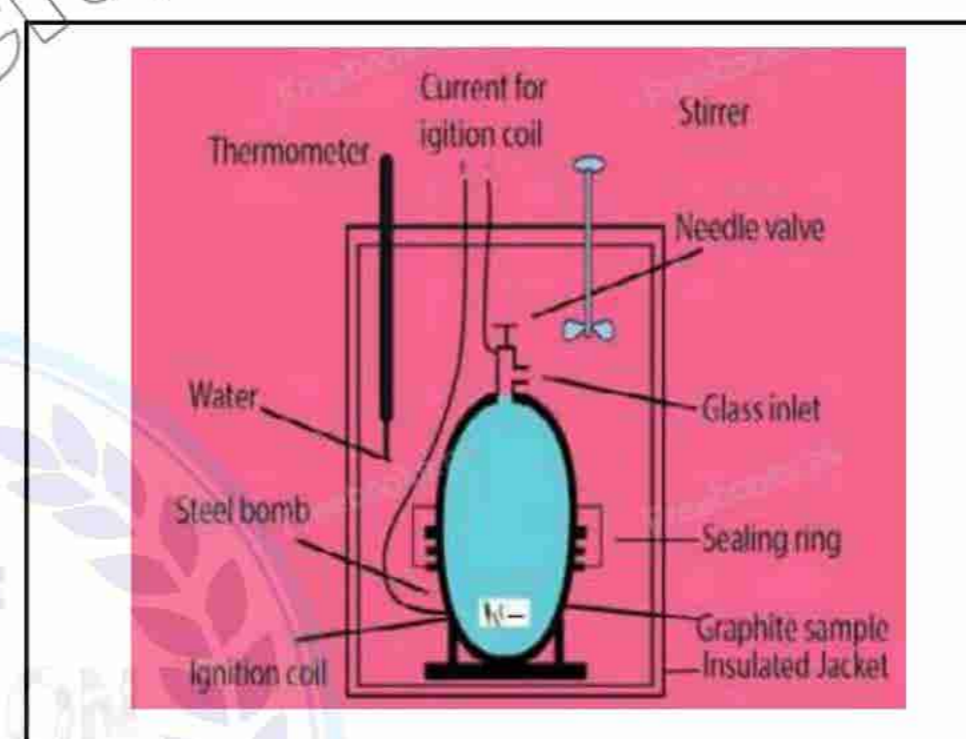

Q. Define heat capacity.

The heat capacity 'c' of a body or a system is defined as the quantity of heat required to change its temperature by 1 kelvin.

Hess's Law of Constant Heat Summation

(Learn for Short Questions and Long Question)

Q. State Hess's Law of Constant Heat Summation.

If a chemical change takes place by several different routes, the overall energy change is the same, regardless of the route by which the chemical change occurs, provided the initial and final conditions are the same.

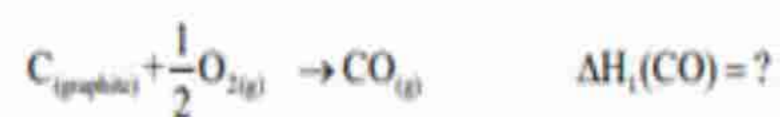

$$\Delta H = \Delta H_1 + \Delta H_2$$

$$\Delta H_1 = \Delta H - \Delta H_2$$

$$= -393 - (-283)$$

$$= -110 \text{ kJ mol}^{-1}$$

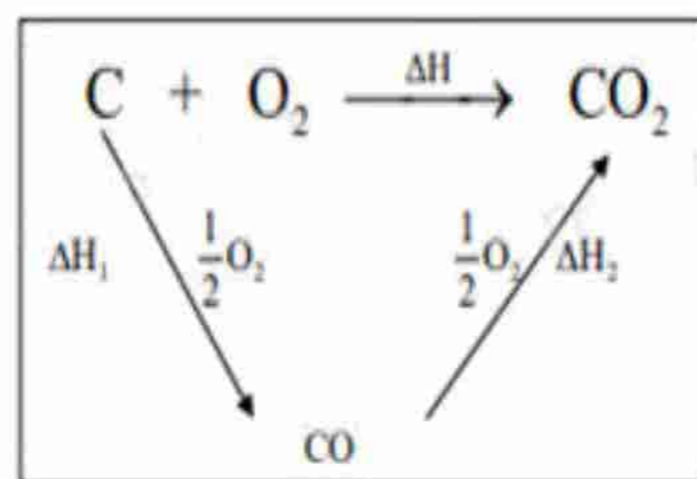

Single Step Process



Two Step Process

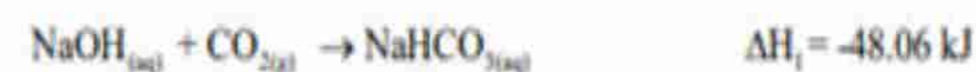

According to Hess's law,

$$\Delta H = \Delta H_1 + \Delta H_2$$

Putting the values of ΔH , ΔH_1 , ΔH_2

$$-89.08 = -48.06 - 41.02$$

$$-89.08 = -89.08$$

According to Hess's law, $\Delta H = \Delta H_1 + \Delta H_2 + \Delta H_3$

$$\text{Mathematically, } \sum \Delta H(\text{cycle}) = 0$$

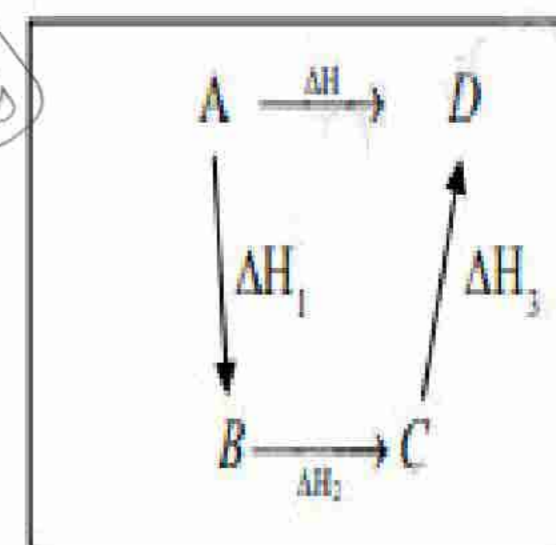

Born Haber Cycle

The energy change in a cyclic process is zero.

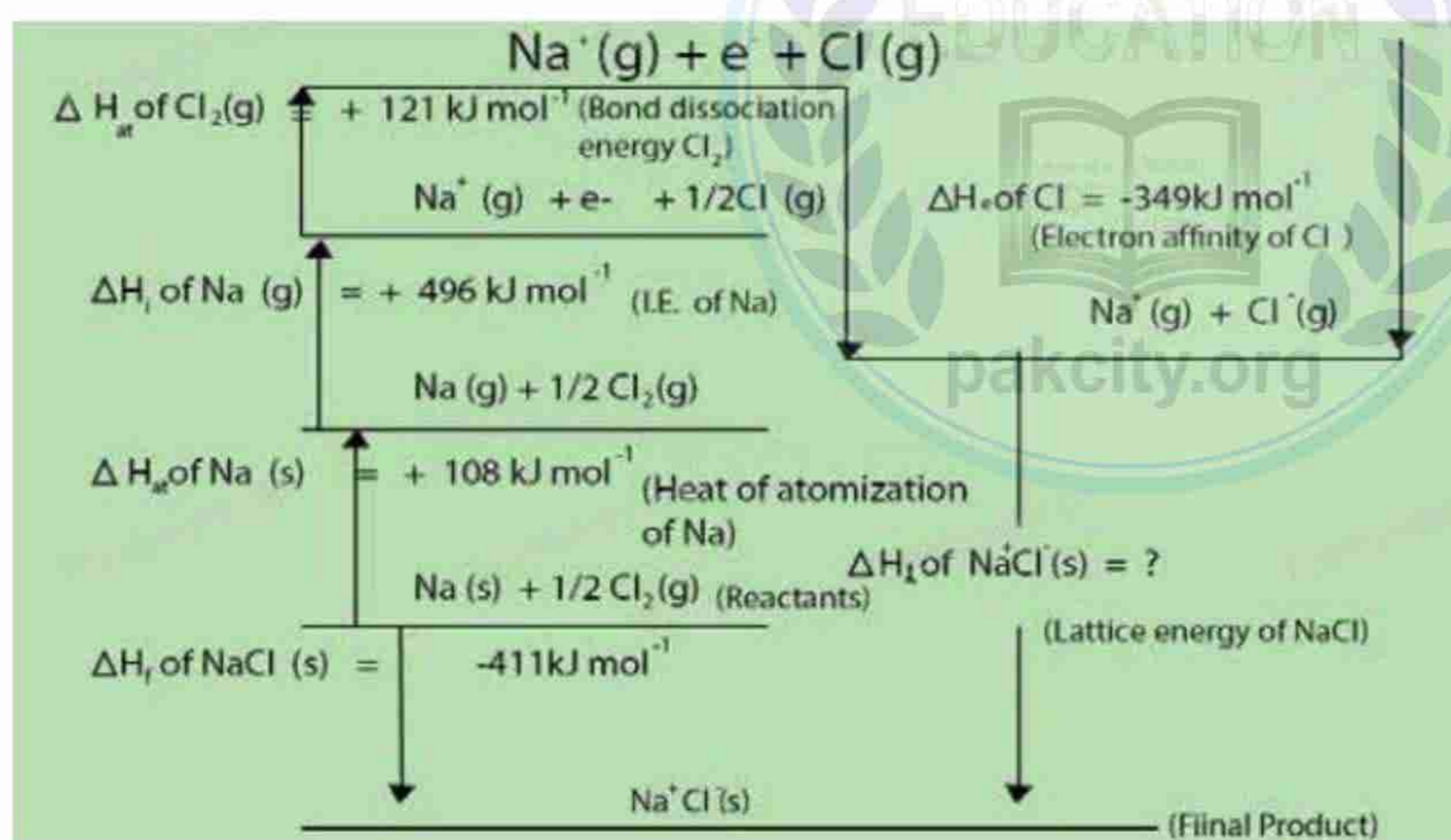

$$\Delta H_f^\circ = \Delta H_1^\circ + \Delta H_x$$

$$\Delta H_1^\circ = \Delta H_f^\circ - \Delta H_x$$

$$\Delta H_1 = -411 - 376 = -787 \text{ kJ mol}^{-1}$$

Chapter 08

Chemical Equilibrium

Q. What is meant by state of chemical equilibrium.

When the rate of forward reaction becomes equal to the rate of reverse reaction then it is called state of chemical equilibrium.

Reversible and Irreversible Reactions

Q. Define reversible and irreversible reaction. Give examples.

A reversible reaction is a reaction in which the **conversion of reactants to products and the conversion of products to reactants occur simultaneously**. For example,

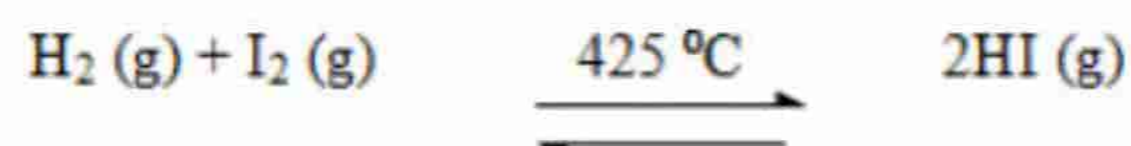

An irreversible reaction is a reaction that **proceeds in one direction only**. The products do not react together to form the reactants. For example,



Law of Mass Action

Q. State law of mass action.

It states that the **rate** at which the reaction proceeds **is directly proportional to the product of the active masses of the reactants**.



$$K_c = \frac{[\text{C}]^c [\text{D}]^d}{[\text{A}]^a [\text{B}]^b}$$

$$[\text{A}]^a [\text{B}]^b$$

Q. How K_p and K_c are related?



$$K_c = \frac{c^c \text{C} \cdot d^d \text{D}}{a^a \text{A} \cdot b^b \text{B}}$$

When the concentrations are expressed in terms of partial pressures, the expression of K_p is:

$$K_p = \frac{P_C^c P_D^d}{P_A^a P_B^b}$$

The following relationship between K_p and K_c can be derived by using Dalton's law of partial pressures.

$$K_p = K_c (RT)^{\Delta n}$$

Applications of Equilibrium Constant

Q. How equilibrium constant helps to determine direction of reaction?

$$K_c = \frac{[C]^c [D]^d}{[A]^a [B]^b}$$

- (a) The **ratio is less than K_c** . The reaction will proceed in the **forward direction**.
- (b) The **ratio is greater than K_c** . It means that the **reverse reaction** will occur to attain the equilibrium.
- (c) When the **ratio is equal to K_c** , then the **reaction is at equilibrium**.

Q. How the value of K_c helps to determine extent of reaction?

- (a) If the **equilibrium constant is very large**, this indicates that the **reaction is almost complete**. For example, for ozone to oxygen $K_c = 10^{55}$ at 25 °C.
- (b) If the value of **K_c is small**, it reflects that the reaction **does not proceed appreciably in the forward direction**.
- (c) If the value of **K_c is very small**, this shows **a very little forward reaction**. For example, for decomposition of HF $K_c = 10^{-13}$ at 2000 °C.

Le-Chatelier's Principle

Q. State Le-Chatelier's Principle.

This principle states that if a stress is applied to a system at equilibrium, the system acts in such a way so as to nullify, as far as possible, the effect of that stress.

Q. Discuss the change of concentration of a product on reversible reaction.



BiCl_3 reacts with water to give a white insoluble compound BiOCl . If a **small amount of HCl is added to this solution**, it will disturb the equilibrium and the reaction will move in the **backward direction** and a **clear solution** will be obtained. If **water is added** to the above solution the **system will move in the forward direction** and the solution will **again become cloudy**.

Q. How change in volume disturbs the equilibrium position for some of the gas phase reactions but not the equilibrium constant?

Those gaseous phase reversible reactions which happen with changing number of moles are affected by the change of volume at equilibrium stage. Their equilibrium position is disturbed but equilibrium constant is not changed.



Q. The change of temperature disturbs the equilibrium position and the equilibrium constant of reaction. Justify.

All the reversible reactions are disturbed by changing their equilibrium position and equilibrium constant by disturbing the temperature. Actually, change of temperature changes the energy contents of reactants and products.

Q. How does a catalyst affect a reversible reaction?

A catalyst increases the rate of reaction by lowering the activation energy and giving new path to the reaction. The value of equilibrium constant as well as equilibrium position remains the same.

Applications of Chemical Equilibrium in Industry

Haber's Process: The pressure of **200-300 atm** and temperature around **673 K (400°C)**. The catalyst is the **pieces of iron crystals embedded in a fused mixture of MgO, Al₂O₃ and SiO₂**.

Sulphur trioxide: A mixture of **SO₂ and O₂ (air)** at **1 atm pressure** is passed over a solid catalyst at **650 °C**. The most effective catalysts are **V₂O₅** and **finely divided platinum**.

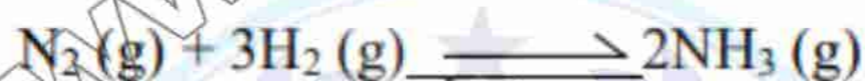

This is a gaseous reaction having **less number of moles of products**. So this reaction happens with the decrease of volume. The **increase of pressure will shift the equilibrium position of reaction to the forward direction**. Equilibrium constant does not change.

Same is the case with the formation of sulphur trioxide.



Ionic Product of Water

Q. What is ionic product of water and how it varies with temperature?



$$1.8 \times 10^{-16} \times 55.5 = 1.01 \times 10^{-14} = [\text{H}^+][\text{OH}^-]$$



This 1.01×10^{-14} is called K_w of water of 25°C

$$K_c = \frac{[\text{H}^+][\text{OH}^-]}{[\text{H}_2\text{O}]} = 1.8 \times 10^{-16} \text{ moles dm}^{-3}$$

$$K_c[\text{H}_2\text{O}] = [\text{H}^+][\text{OH}^-]$$

$$K_w = [\text{H}^+][\text{OH}^-] = 10^{-14} \text{ at } 25^\circ\text{C}.$$

The value of K_w increases almost 75 times when temperature is increased from 0°C to 100°C .

Q. Define pH and pOH.

pH is negative log of hydrogen ion concentration and pOH is negative log of hydroxyl ion concentration.

$$\text{pH} = -\log [\text{H}^+]$$

$$\text{pOH} = -\log [\text{OH}^-]$$

Q. Calculate the pH of $10^{-4} \text{ mol.dm}^{-3}$ solution of HCl and $10^{-4} \text{ mol.dm}^{-3}$ soln of $\text{Ba}(\text{OH})_2$.

$$\text{pH} = -\log [\text{H}^+]$$

$$= -\log [10^{-4}]$$

$$= -(-4)\log [10]$$

$$= 4$$

$$\text{as } \log 10 = 1$$



$$[\text{OH}^-] = 2 \times 10^{-4} \text{ mol.dm}^{-3}$$

$$\text{pOH} = -\log 2 \times 10^{-4}$$

$$= 3.69$$

$$\text{pH} = 14 - \text{pOH}$$

$$= 14 - 3.69$$

$$= 10.31$$

Buffers

Q. Define buffers. Mention types.

Those **solutions**, which **resist the change in their pH** when a small amount of an acid or a base is added to them, are called buffer solutions.

(i) **Acidic buffers:** By mixing a weak acid and a salt of it with a strong base. Such solutions give pH less than 7. Mixture of CH_3COOH and CH_3COONa .

(ii) **Basic buffers:** By mixing a weak base and a salt of it with a strong acid. Such solutions give pH more than 7. Mixture of NH_4OH and NH_4Cl .

Q. Define buffer capacity.

The buffer capacity of a solution is the **capability of a buffer to resist the change of pH.**

Q. What is Henderson's equation and for what purpose it is used?

For acidic buffer Henderson equation is:

$$\text{pH} = \text{pK}_a + \log \frac{[\text{salt}]}{[\text{acid}]}$$

For basic buffer Henderson equation is:

$$\text{pOH} = \text{pK}_b + \log \frac{[\text{salt}]}{[\text{base}]}$$

It helps to make buffer of desired pH

Q. How do the buffers act? Give an example.

CH₃COOH, being a weak electrolyte undergoes very little dissociation. When CH₃COONa is added to CH₃COOH solution, then the dissociation of CH₃COOH is suppressed, due to common ion effect of CH₃COO⁻



Added concentrations of CH₃COO⁻ decrease the dissociation of CH₃COOH and the pH of solution increases.

When an acid or H₃O⁺ ions are added to this buffer, they will react with CH₃COO⁻ to give back acetic acid and hence the pH of the solution will almost remain unchanged.

Lowry-Bronsted Acid Base Concept**Q. What is Lowry-Bronsted acid base concept?**

An acid is a specie which is a proton donor and base is a specie which is a proton acceptor.

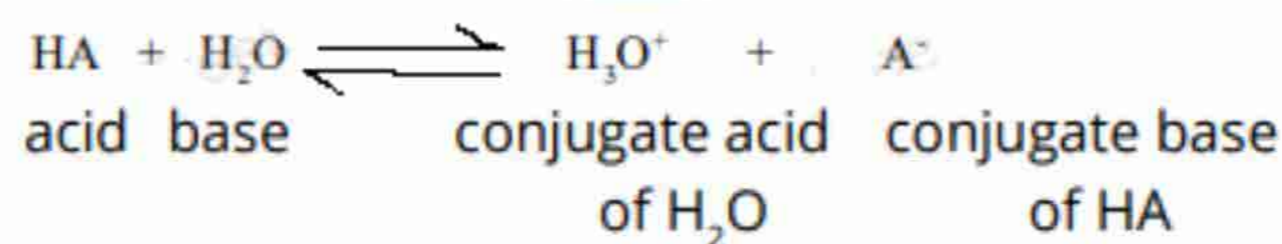
**Q. How percentage of ionization of acid is determined?**

$$\% \text{ionization} = \frac{\text{Amount of acid ionized}}{\text{Amount of acid initially available}} \times 100$$

Common Ion Effect

Q. What is common ion effect. Give two applications.

The suppression of ionization of a weak electrolyte by adding a common ion from outside is called common ion effect.

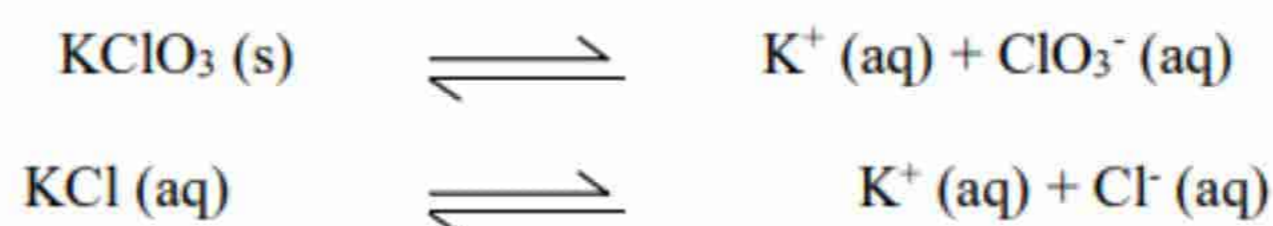

KClO₃ is precipitated out.

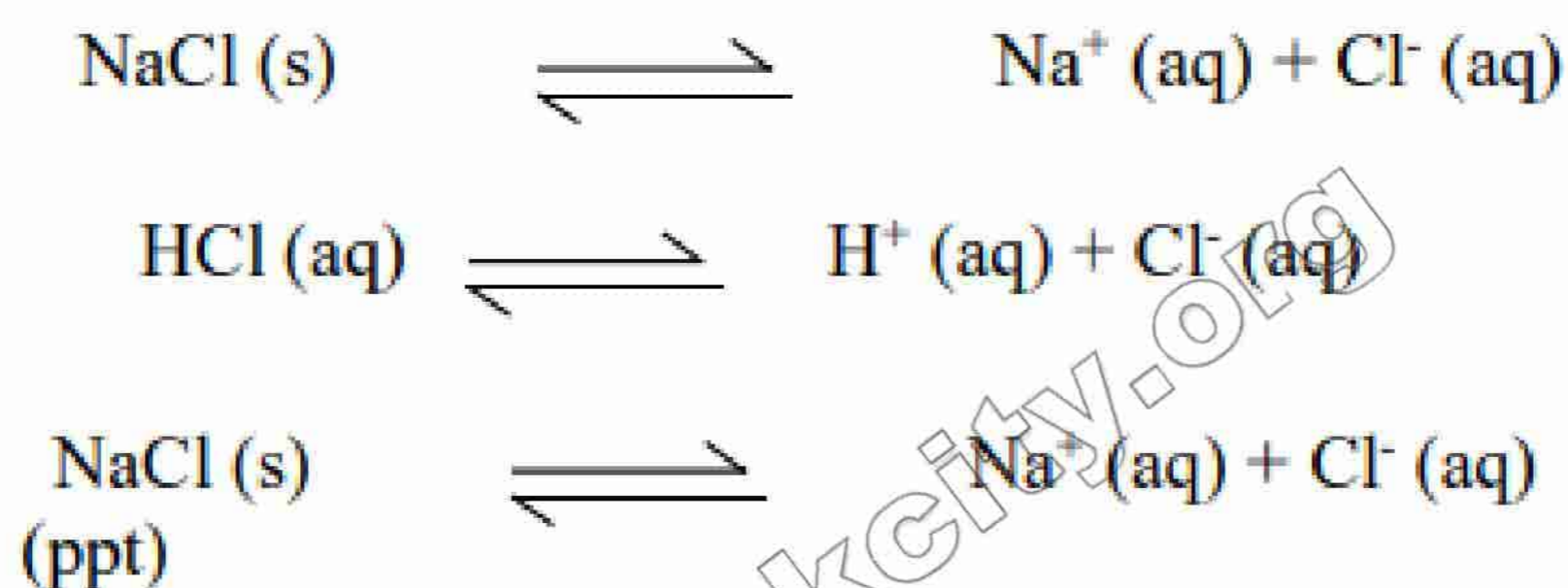

Solubility Product

Q. Define solubility product. Derive solubility product of Ag₂CrO₄ and PbCl₂.

The solubility product is the product of the concentrations of ions raised to an exponent equal to the co-efficient of the balanced equation.

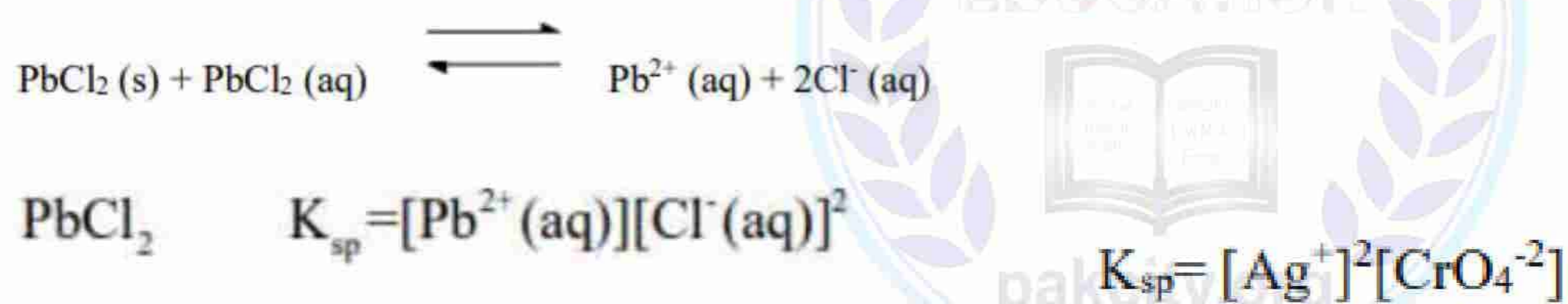

Q. What are the applications of solubility product?

1. Determination of K_{sp} from solubility.
2. Determination of solubility from K_{sp}.

Q. What is the effect of common ion on solubility?

Solubility decreases due to common ion effect. The solubility of PbCrO₄ decreases as Na₂CrO₄ is added to it.

Important Numericals for Long Questions

Example 2

Example 4

Example 5

Example 6

Example 7

Exercise Numerical 23 (a) , 23 (b)

Exercise Numerical 24

Exercise Numerical 25



Chapter 9

Solutions



Q. Define molarity and molality. Give examples.

Molarity is the number of moles of solute dissolved per dm^3 of the solution. To prepare one molar solution of glucose in water, we take 180 g of glucose and add sufficient water to make the total volume 1 dm^3 (litre) in a measuring flask.

$$\text{Molarity (M)} = \frac{\text{Number of moles of solute}}{\text{Volume of solution (dm}^3\text{)}}$$

Molality is the number of moles of solute in 1000 g (1 kg) of the solvent. In order to prepare molal solutions, we don't have to take any flask. 180 g of glucose when dissolved in 1000 g of water gives one molal solution of glucose.

$$\text{Molality (m)} = \frac{\text{Number of moles of solute}}{\text{Mass of solvent in kg}}$$

Q. Why molality is independent of temperature but molarity depends upon temperature?

In molal solutions the mass of the solvent and that of the solute are also fixed. The masses of the substances are not temperature dependent. In molar solutions we have the volumes of solutions. Volume of a liquid is temperature dependent. So, the molality is not influenced by temperature but molarity does change.

$$\text{Molality} = \frac{\text{Moles of solute}}{\text{Mass of solvent in Kg}}$$

$$\text{Molarity} = \frac{\text{Moles of solute}}{\text{Volume of solution in dm}^3}$$

Q. Define mole fraction and parts per million (ppm).

It is defined as the **number of parts of a solute per million parts of the solution**. This unit is used for very low concentrations of solutions, e.g. to express the impurities of substances in water.

$$\text{Parts per million (ppm)} = \frac{\text{Mass of solute}}{\text{Mass of solution}} \times 10^6$$

The **mole fraction of any component** in a mixture is the ratio of the number of moles of it to the total number of moles of all the components present.

$$X_A = \frac{P_A}{P_A + P_B + P_C} \quad , X_B = \frac{P_B}{P_A + P_B + P_C} \quad , X_C = \frac{P_C}{P_A + P_B + P_C}$$

Q. Why molal solution is dilute as compared to molar solution?

Molal solution is dilute as compared to molar solution because in molal solution 1 kg of solvent is used whereas in molar solution 1 litre of solvent is used. As 1 kg solvent is more than 1 litre solvent so molal solution is dilute as compared to molar solution.

Types of Solutions**Q. Define conjugate solution. Give an example.**

The solution of two partially miscible liquids is called conjugate solution.

Example: Solution of phenol and water.

Phenol-water system**(Learn for Short Question and Long Question)**

If equal volumes of water and phenol are mixed together they show partial miscibility. It has been observed that around room temperature phenol will dissolve in a lot of water giving us the upper layer and water will dissolve in a lot of phenol giving us the lower layer. **At 25 °C the upper layer is 5% solution of phenol in water and the lower layer is 30% water in phenol.** These two solutions are **conjugate solutions to each other**. The lower layer has a greater density due to greater percentage of phenol. Water acts as a solute in the lower layer while phenol is a solute in the upper layer. **When the temperature of water-phenol system is increased, the compositions of both layers change.** Water starts travelling from upper to the lower layer and phenol travels from lower to the upper layer. When the temperature of this system approaches **65.9 °C, a homogeneous mixture of two components is obtained.** This homogeneous mixture contains **34% phenol and 66% water.**

Ideal and Non-Ideal Solutions**(Learn for Short Question and Long Question)**

Following points are the differences between ideal and non-ideal solution:

- If the **forces of interactions** between the molecules of different components are **same as when they were in the pure state**, they are **ideal** solutions, otherwise non-ideal.
- If the **volume of solution is not equal to the sum of the individual volumes of the components**, the solution is **non-ideal**.
- Ideal solutions have zero enthalpy change** as their heat of solution.
- If the solutions **obey Raoult's law then they are ideal**. This is one of the best criterion for checking the ideality of a solution.

Raoult's Law**(Learn for Short Question and Long Question)****Q. State Raoult's law. OR Give two statements of Raoult's law.**

1. The vapour pressure of a solvent above a solution is equal to the product of the vapour pressure of pure solvent and the mole fraction of solvent in solution.

$$p = p^{\circ} x_1$$

2. The lowering of vapour pressure of a solvent is directly proportional to the mole fraction of solute.

$$\Delta p/p^{\circ} = x_2$$

Relative lowering of vapour pressure is more important.

3. The relative lowering of vapour pressure is equal to the mole fraction of solute.

Q. Why the relative lowering of vapour pressure is independent of temperature?

The expression of relative lowering of vapour pressure is as follows:

$$\Delta p/p^{\circ} = x_2$$

In this expression temperature is not involved so it is independent of temperature.

The relative lowering of vapour pressure:

- (i) Temperature independent.
- (ii) Solute concentration dependent.
- (iii) is constant when equimolecular proportions of different solutes are dissolved in the same mass of same solvent.

Fractional Distillation of Ideal Mixture of Two Liquids

(Learn for Long Question)

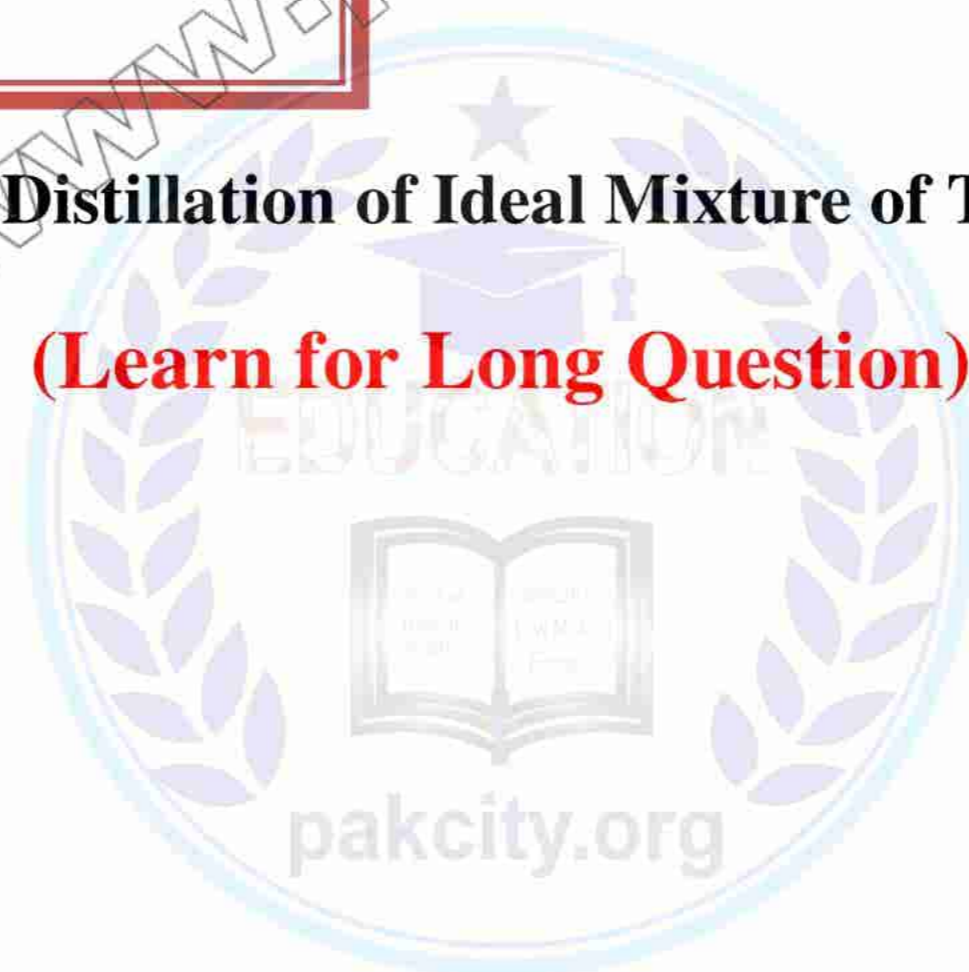

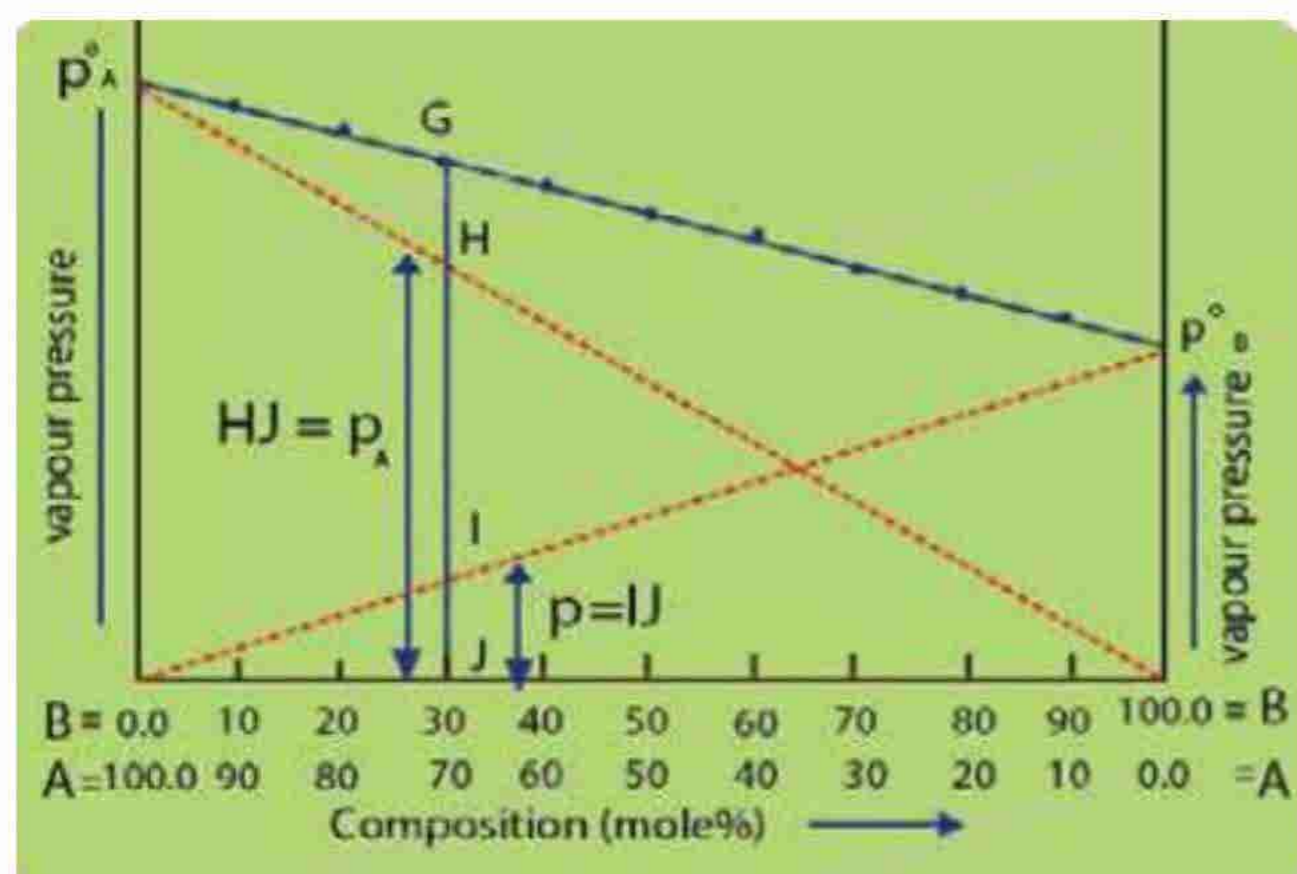

Two liquids 'A' and 'B' with vapour pressures p_A° and p_B° in the pure state at a given temperature.

After making the solution, the vapour pressures of both liquids are changed.

Let the vapour pressures of these liquids in solution state be p_A and p_B with their mole fractions x_A and x_B respectively.

The vapour pressure of A is more than B at a given temperature

$$p_A = p_A^\circ x_A$$

$$p_B = p_B^\circ x_B$$

$$P_t = p_A + p_B = p_A^\circ x_A + p_B^\circ x_B \text{ where } P_t \text{ is total vapour pressure}$$

$$x_A + x_B = 1$$

$$x_B = 1 - x_A$$

$$P_t = p_A^\circ x_A + p_B^\circ (1 - x_A)$$

$$P_t = p_A^\circ x_A + p_B^\circ - p_B^\circ x_A$$

$$P_t = (p_A^\circ - p_B^\circ)x_A + p_B^\circ$$

Q. What are zeotropic and azeotropic mixtures?

Such **liquid mixtures which distil with a change in composition** are called zeotropic mixtures. For example, **methyl alcohol-water solution** can be separated into pure components by distillation.

Azeotropic mixtures are those which **boil at constant temperature and distil over without change in composition** at any temperature like a pure chemical compound.

Solubility and Solubility Curves

(Learn for Short Questions and Long Question)

Q. Define solubility. Give an example.

The solubility is defined as **the concentration of the solute in the solution when it is in equilibrium with the solid substance at a particular temperature**. For example, saturated solution of NaCl in water at 0°C contains 37.5g of NaCl in 100 g of water.

Q. Define solubility curves.

A **graphical representation between temperature and solubility of solution** is called solubility curves. There are two types of solubility curves.

- Continuous solubility curves
- Discontinuous solubility curves

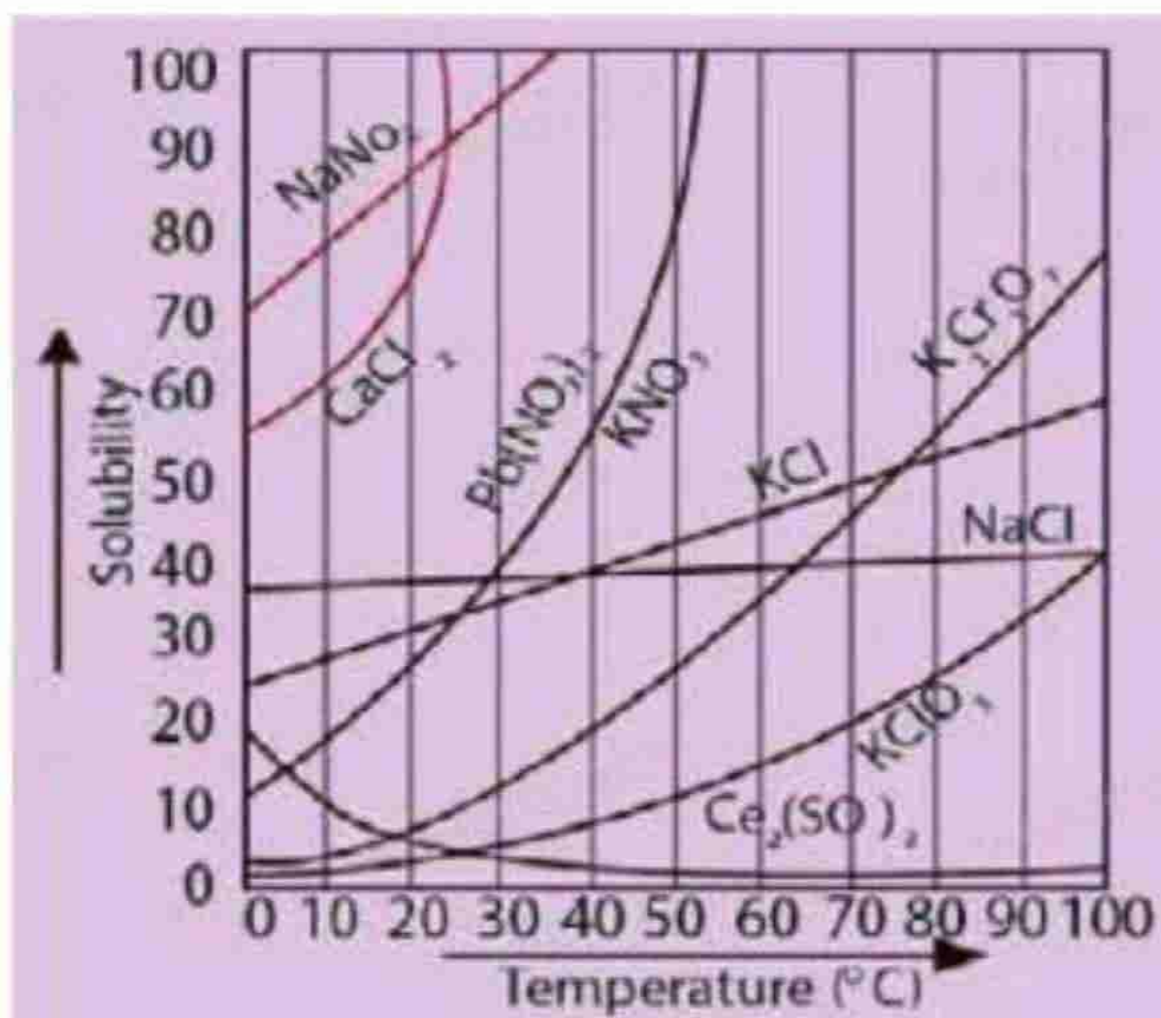

Continuous solubility curves don't show sharp breaks anywhere.

KClO_3 , $\text{K}_2\text{Cr}_2\text{O}_7$, $\text{Pb}(\text{NO}_3)_2$ and CaCl_2 are showing continuous solubility curves. The solubility curves of **KCl, NaCl and NaNO_3** give the straight lines.

$\text{Ce}_2(\text{SO}_4)_3$ solubility decreases with the increase in temperature and becomes constant from 40°C

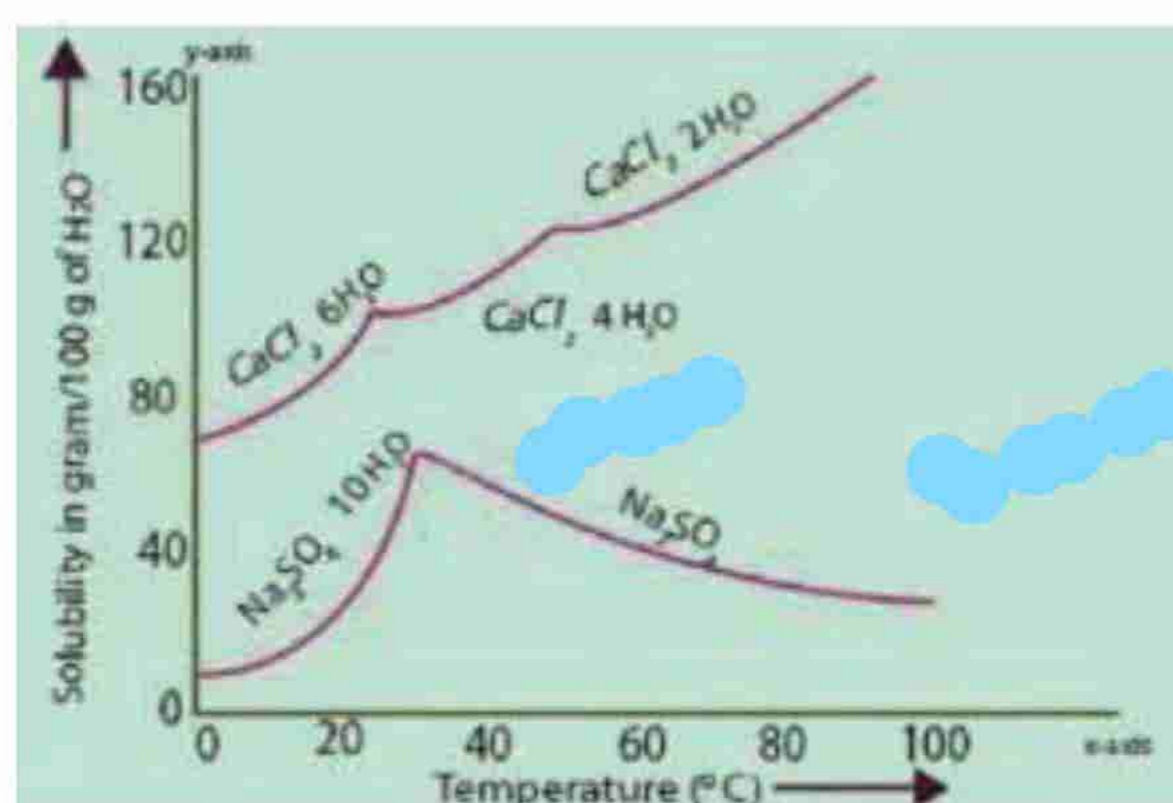

The solubility curves show sudden changes of solubilities and these curves are called **discontinuous solubility curves**. Examples are $\text{Na}_2\text{SO}_4 \cdot 10\text{H}_2\text{O}$, $\text{CaCl}_2 \cdot 6\text{H}_2\text{O}$.

At the break a new solid phase appears and another solubility curve of that new phase begins. **It is the number of molecules of water crystallization which**

Q. Define fractional crystallization.

Fractional crystallization is a technique **for the separation of impurities from the chemical products**. The impure solute is dissolved in a hot solvent in which the desired solute is less soluble. As the hot solution is cooled, the desired solute separates out first from the mixture. In this way, pure desired product crystallizes out from the solution.

Colligative Properties of Solutions

(Learn for Short Questions and Long Questions)

Q. Define colligative properties.

The colligative properties are the **properties of solution that depend on the number of solute and solvent molecules or ions**.

(i) Lowering of vapour pressure (ii) Elevation of boiling point (iii) Depression of freezing point (iv) Osmotic pressure

Conditions

- (i) Solution should be dilute
- (ii) Solute should be non-volatile
- (iii) Solute should be non-electrolyte.

Q. Define ebullioscopic constant and cryoscopic constant.

The **elevation in boiling point of 1 molal solution of non-volatile non-electrolyte solute in water** as solvent is **0.52 °C**. It is also called molal boiling point elevation constant or ebullioscopic constant.

$$\Delta T_b = K_b m$$

The unit of K_b is $^{\circ}\text{C Kg mol}^{-1}$

The **depression in freezing point of 1 molal solution of non-volatile non-electrolyte solute in water** as solvent is **1.86 °C**. It is called molal freezing point depression constant or cryoscopic constant.

Q. Define upper consolute temperature.

The temperature at which two conjugate solutions merge into one another is called critical solution temperature or upper consolute temperature. Example: Upper consolute temperature of phenol water system is 65.9°C.

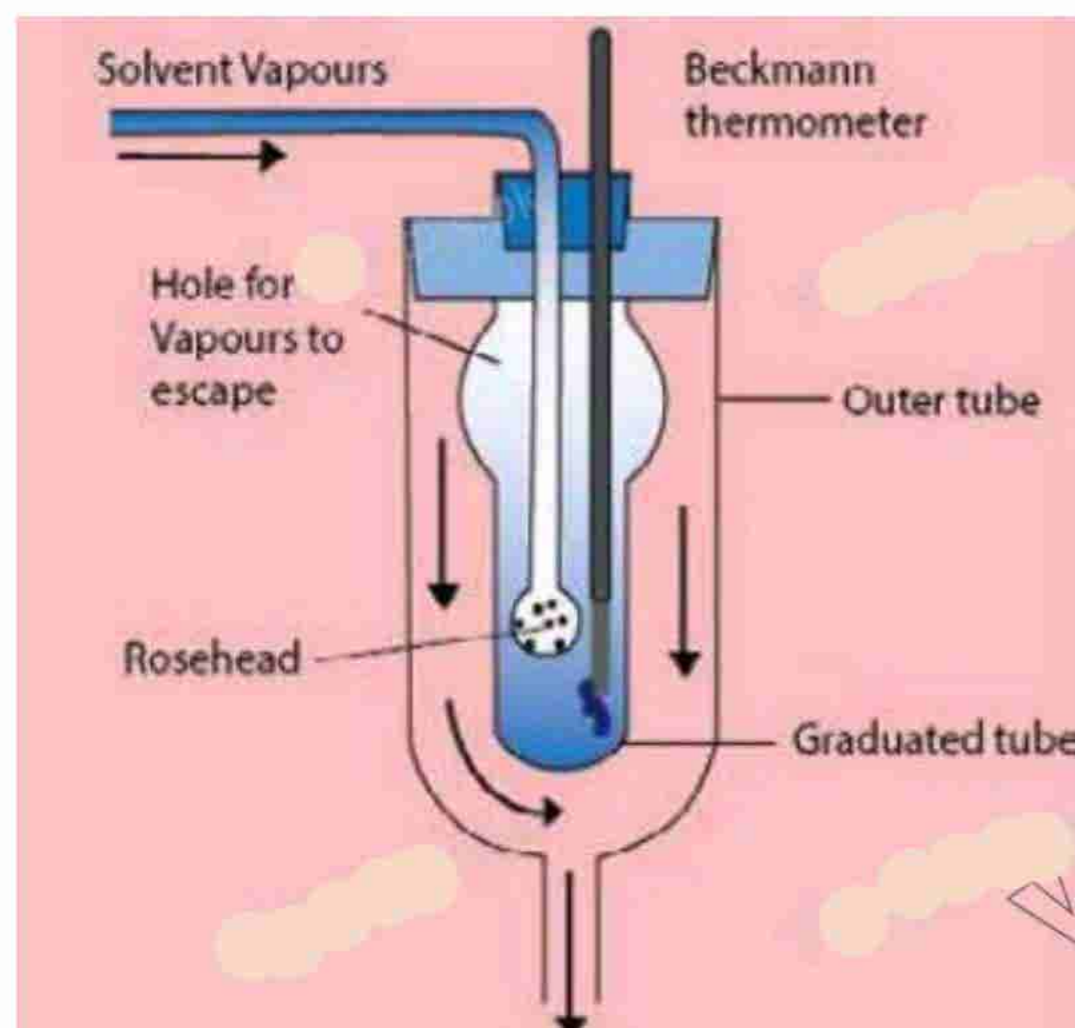
Measurement of Boiling Point Elevation

The solvent is placed in the inner tube. Some solvent is also taken in a separate flask and its vapours are sent into this tube. **These vapours cause the solvent in the tube to boil by its latent heat of condensation.** This temperature is noted which is the **boiling point of the pure solvent**. The supply of the vapours is temporarily cut off and a **weighed pellet of the solute is dropped in the inner tube**. The **vapours of the solvent are again passed through it until the solution is boiled**. This **temperature** is again noted.

$$M_2 = \frac{K_b}{\Delta T_b} \frac{1000 W_2}{W_1}$$

Parts

- An inner tube with a hole in its side. This tube is graduated.
- A boiling flask which sends the solvent vapours into the graduated tube through a rosehead.
- An outer tube, which receives hot solvent vapours coming from the side hole of the inner tube.
- A thermometer which can read up to 0.01K

Measurement of Freezing Point Depression

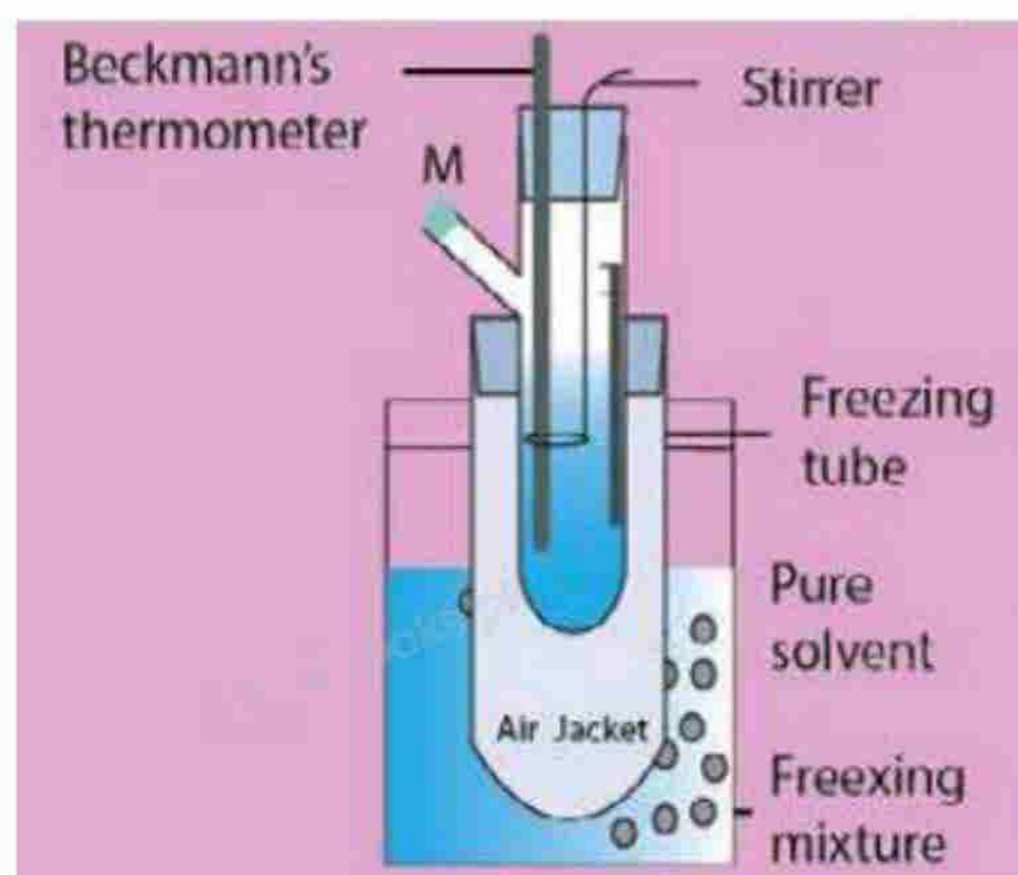

- A freezing tube with a side arm.
- An outer larger tube into which the freezing tube is adjusted.
- A large jar containing a freezing mixture. Around 20 to 25g of the solvent is taken in the freezing tube.

Beckmann method

Approximate freezing point of the solvent is measured by directly cooling the freezing point tube in the freezing mixture.

The freezing tube is then put in the air jacket and cooled slowly. Accurate freezing point of the solvent is determined. Now, the solvent is re-melted by removing the tube from the bath and weighed amount of 0.2 to 0.3 g of the solute is introduced in the side tube. The freezing point of the solution is determined. ΔT_f determined.

$$M_2 = \frac{K_f}{\Delta T_f} \frac{1000 W_2}{W_1}$$

Applications of Boiling Point Elevation and Freezing Point Depression Phenomenon

Q. Why ethylene glycol is used as an anti-freeze in car radiators?

Ethylene glycol is used as an antifreeze in the radiator of an automobile. It lowers the freezing point as well as raises the boiling point. During winter it protects a car by preventing the liquid in the radiator from freezing. In hot summer, the antifreeze solution also protects the radiator from boiling over.

Energetics of Solution

Q. Differentiate between hydration and hydrolysis.

Hydration is the process in which water molecules surround and interact with solute ions or molecules. When a salt is dissolved in water, it dissociates into cations and anions in hydrolysis.

Chapter 10

Electrochemistry

Q. Define electrochemistry.

Electrochemistry is concerned with the conversion of electrical energy into chemical energy in electrolytic cells as well as the conversion of chemical energy into electrical energy as in galvanic or voltaic cells.

Q. Define oxidation number or state.

It is the apparent charge on an atom of an element in a molecule or an ion. It may be positive or negative or zero. For example, Na^{+1} , S^{-2} , K^{+1}

Q. Define anode and cathode.

The electrode at which oxidation takes place in electrochemical process is called anode and the one at which reduction takes place is called cathode.

Q. Calculate the oxidation number of Cl in $\text{Ca}(\text{ClO}_3)_2$ and Mn in KMnO_4 .



Oxidation number of O = -2
Oxidation number of Ca = +2
Oxidation number of Cl = x

$$\begin{aligned} +2 + 2x + 6(-2) &= 0 \\ 2x &= +12 - 2 = +10 \\ x &= +5 \end{aligned}$$



$$+1 + \text{Mn} + (-2)4 = 0$$

$$\text{Mn} + 1 - 8 = 0$$

$$\text{Mn} = +7$$

Q. Define electronic conduction.

Most metals are conductors of electricity because of the relatively free movement of their electrons throughout the metallic lattice. This electronic conduction is simply called metallic conduction.

Q. Define ionization, electrolytic conduction and electrolysis.

Ionization is the process in which ionic compounds when fused or dissolved in water split up into charged particles called ions.



The movement of ionic charges through the liquid brought by the application of electricity is called electrolytic conduction.

The electrochemical reactions that occur at the electrodes during the electrolytic conduction constitute the phenomenon of electrolysis.

Q. Difference between electrolytic and galvanic cell.

Electrolytic Cell	Voltaic cell
<ol style="list-style-type: none"> The electrochemical cell in which electrical energy is converted into chemical energy is called Electrolytic cell. In this cell, non-spontaneous reaction occurs. Electric current is used to drive the non-spontaneous oxidation reduction reaction. Electrolysis takes place in this cell. <p>Example: Down's cell, Nelson's cell</p>	<ol style="list-style-type: none"> The electrochemical cell in which chemical energy is converted into electrical energy is called Voltaic cell. In this cell, spontaneous reaction occurs. Electric current is produced due to spontaneous reaction. Electric conduction takes place in this cell. <p>Example: Daniel's cell, Fuel cells</p>

Products of Electrolysis in Fused State and Aqueous State

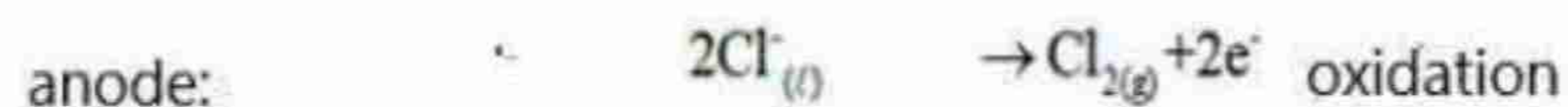
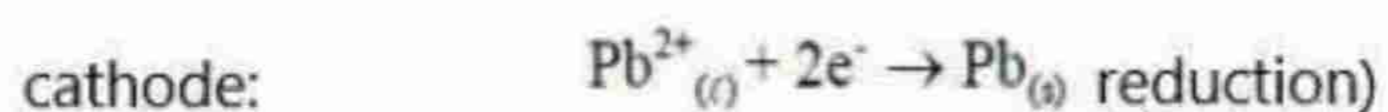

Fused State

Aqueous Solution of Salts

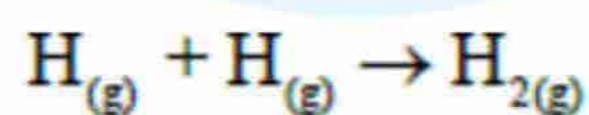

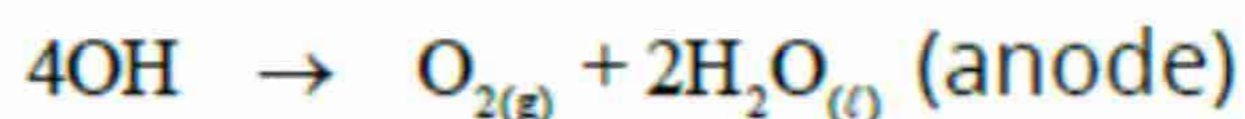

Electrolytic Processes of Industrial Importance

(Learn for Short Questions and Long Questions)

Q. Explain extraction of sodium by Down's cell.

Extraction of sodium by the electrolysis of fused sodium chloride is carried out in Down's cell. In this case, molten sodium chloride is electrolyzed between **iron cathode** and **graphite anode**.

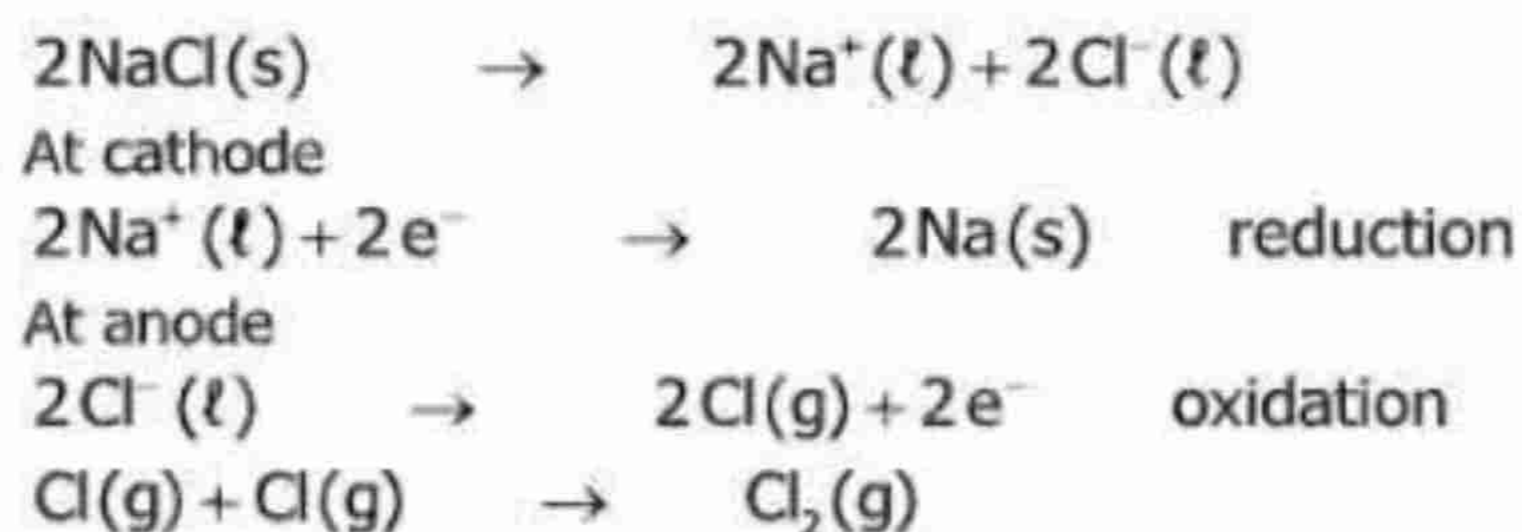

Q. How the process of electrolysis is applied in the production of caustic soda?

Caustic soda is obtained on industrial scale by the electrolysis of concentrated aqueous solution of sodium chloride using titanium anode and mercury or steel cathode. This electrolysis is carried out in Nelson cell and Castner-Kellner cell or Hg-cell.

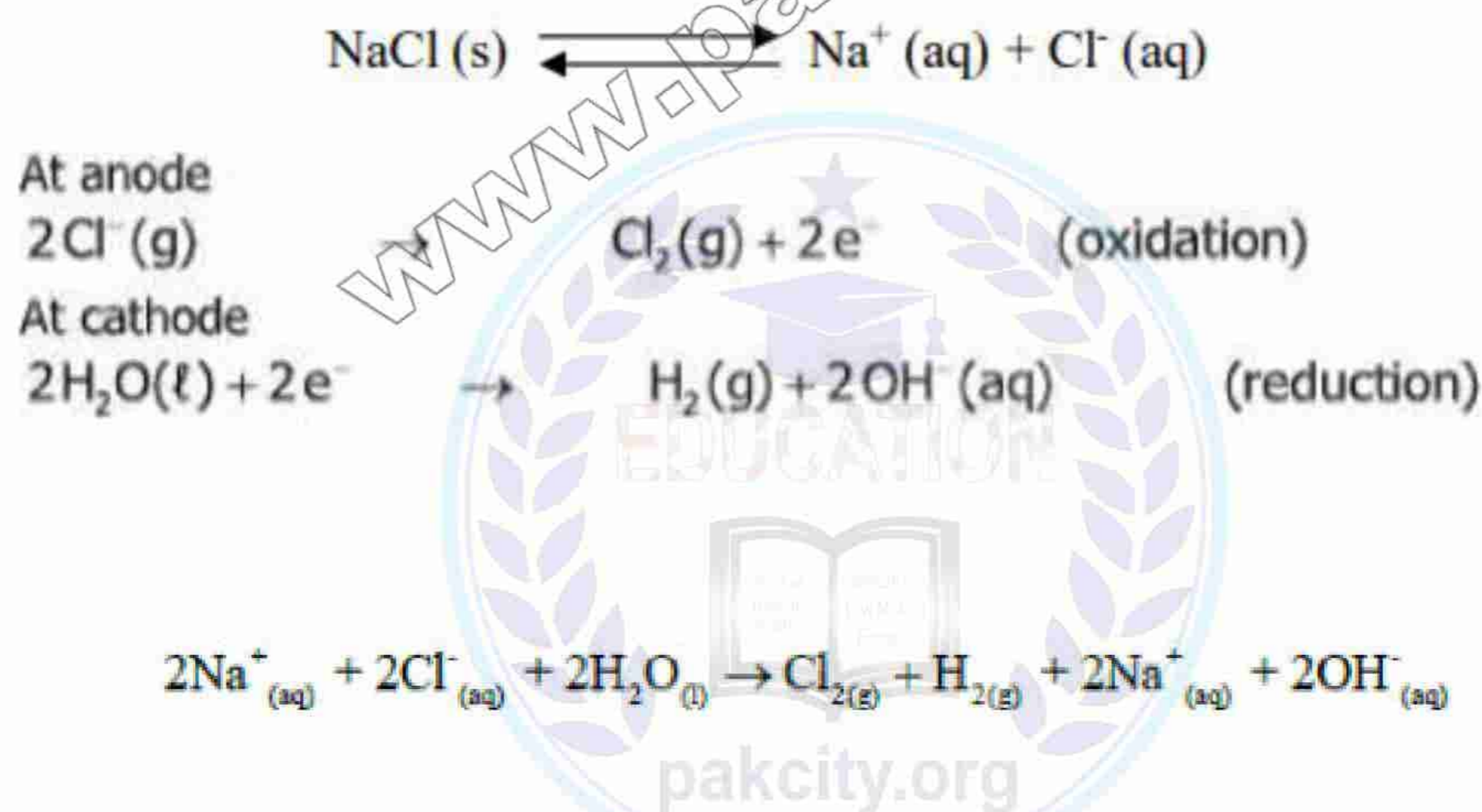

Q. How impure copper is purified by the process of electrolysis?

Impure copper is made the anode and a thin sheet of **pure copper is made the cathode**. **Copper sulphate solution is used as an electrolyte**. The atoms of Cu from impure Cu anode are converted to Cu^{2+} ions and migrate to cathode which is made up of pure Cu. In this way, Cu anode is purified. Impurities are left at anode.

Q. How is anodized aluminium prepared in an electrolytic process?

Anodized aluminium is prepared by making it an anode in an electrolytic cell containing sulphuric acid or chromic acid, which coats a thin layer of oxide on it. The aluminium oxide layer resists attack for corrosive agents. The freshly anodized aluminium is hydrated and can absorb dyes.

Voltaic Cell or galvanic Cell

(Learn for Short Questions and Long Questions)

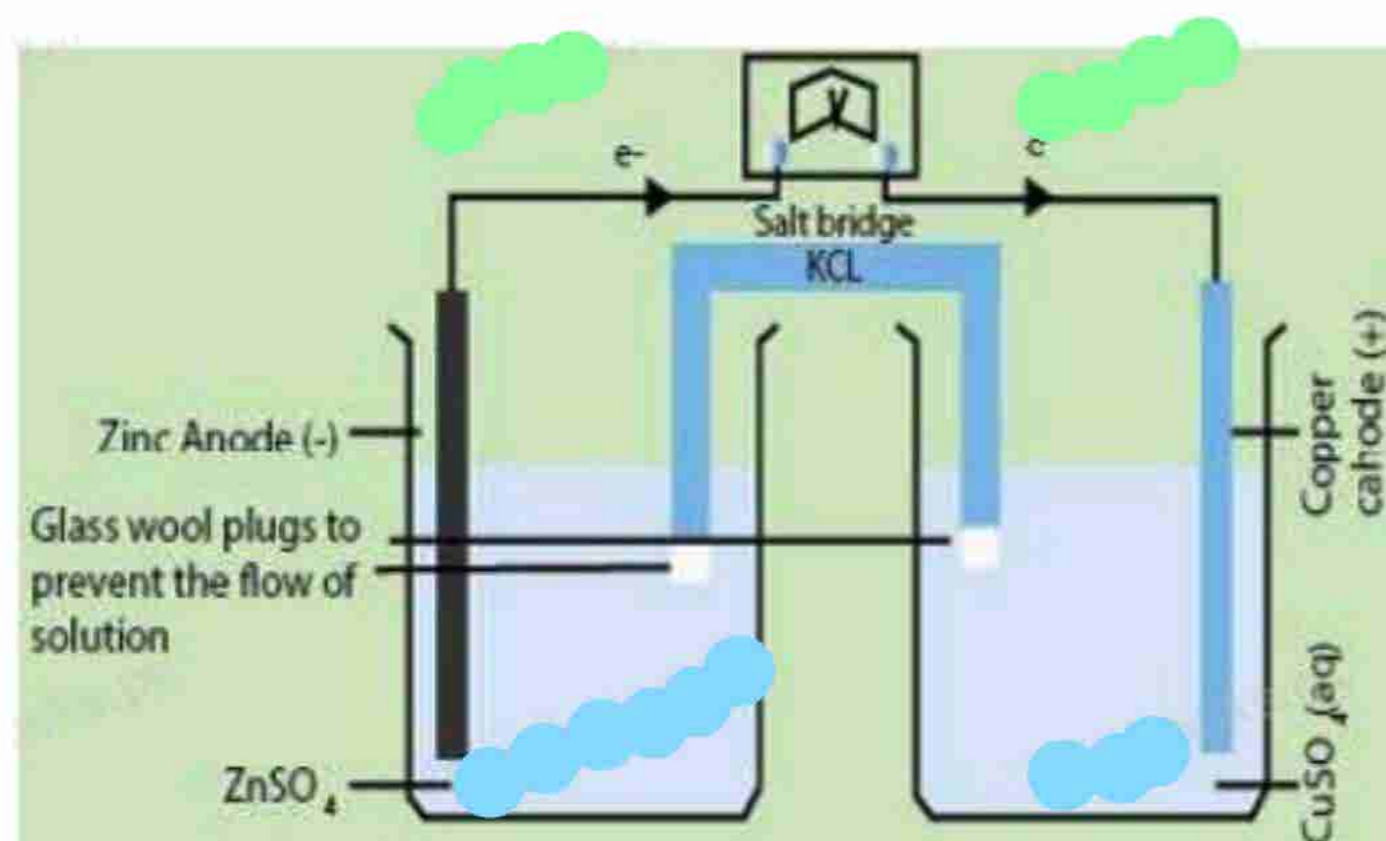

A voltaic cell is one in which chemical energy is converted to electrical energy.

It is a spontaneous cell.

A voltaic or a galvanic cell consists of two half-cells that are electrically connected.

Each half cell is a portion of the total cell in which a half reaction takes place.

The left half cell consists of a strip of zinc metal dipped in 1.0 M solution of zinc sulphate.

The right half-cell is a copper metal strip that dips into 1.0 M copper sulphate solution.

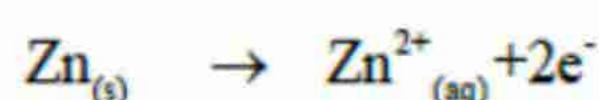

Q. Is voltaic cell a reversible cell?

If the external circuit is replaced by a source of electricity that opposes the voltaic cell, the electrode reactions can be reversed.

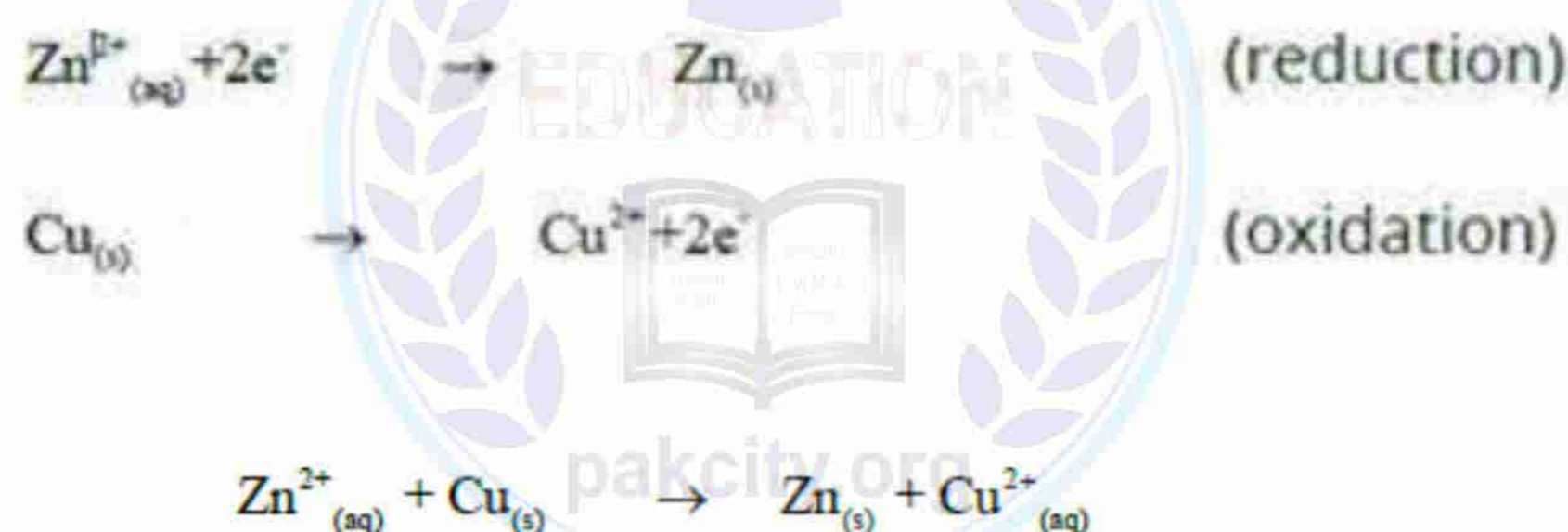

Q. What is the function of salt bridge?

The purpose of the salt bridge is to prevent any net charge accumulation in either beaker by allowing negative ions to leave the right beaker, diffuse through the bridge and enter the left beaker. If this diffusional exchange of ions does not occur, the net charge accumulating in the beakers would immediately stop the flow of electrons through the external circuit and the oxidation reduction reaction would stop.

Electrode Potential

The potential set up when an electrode is in contact with one molar solution of its own ions at 298 K is known as standard electrode potential or standard reduction potential of the element. It is represented as E° .

Standard Hydrogen Electrode (SHE)

(Learn for Short Question and Long Question)

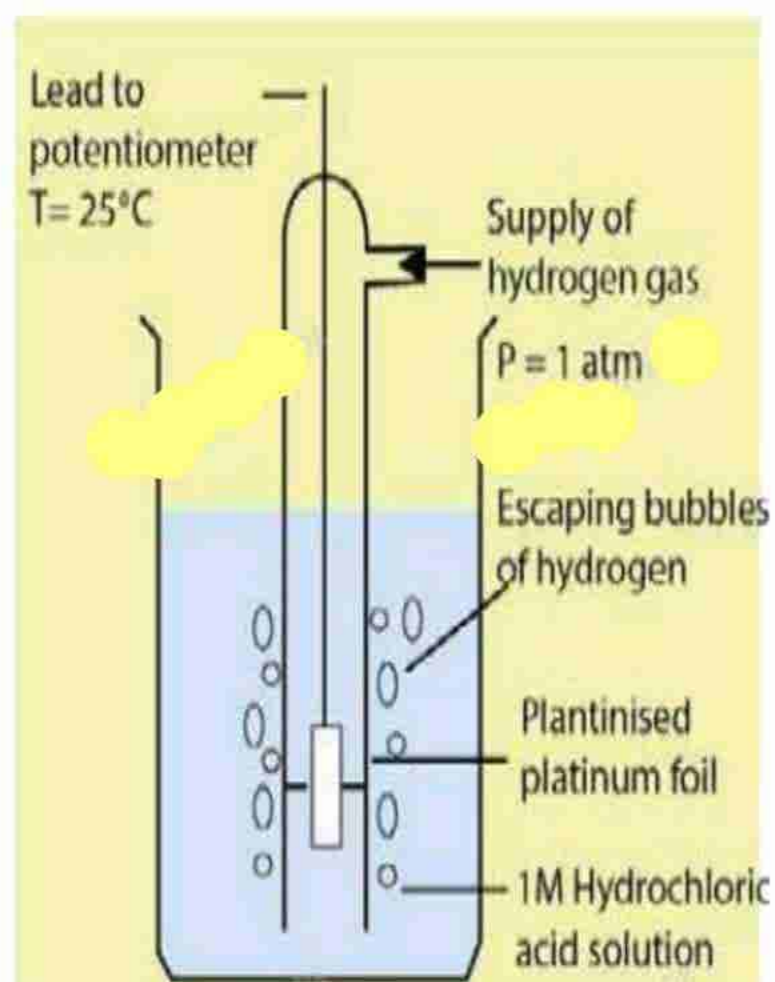

It stands for standard hydrogen electrode.

It consists of a piece of platinum foil, which is coated electrolytically with finely divided platinum black and suspended in one molar solution of HCl. Pure hydrogen gas at one atmosphere pressure is continuously bubbled into 1M HCl solution.

The potential of this electrode is arbitrarily taken as zero.



Q. SHE acts as anode when connected with Cu but acts as cathode when connected with Zn. Justify your answer with equations.

The reduction potential of Copper is +0.34V i.e a positive value, so it brings about reduction and act as cathode and SHE as anode.

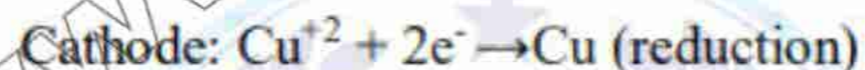
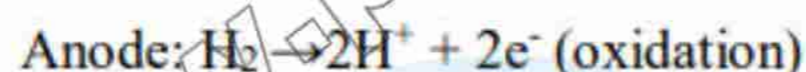

The oxidation potential of Zn is +0.76V i.e a positive value so Zn brings about oxidation and act as anode while SHE act as cathode.

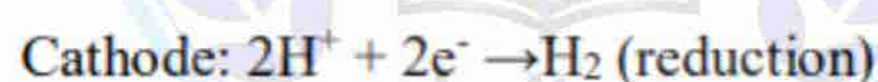
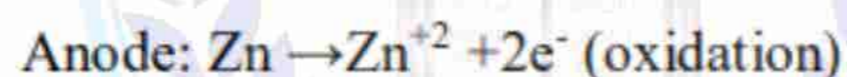

Electrochemical Series

(Learn for Short Question and Long Question)

When elements are arranged in the order of their standard, electrode potentials on the hydrogen scale, the resulting list is known as electrochemical series.

Q. How electrochemical series predict feasibility of a reaction?

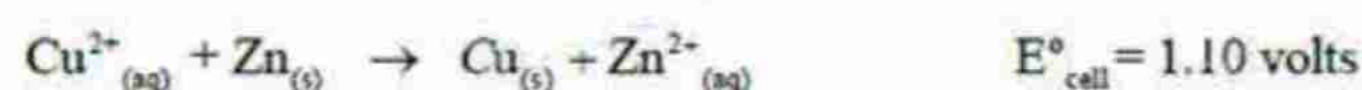

Positive value of reaction potential shows reaction is possible

Q. How electrochemical series help to calculate voltage?

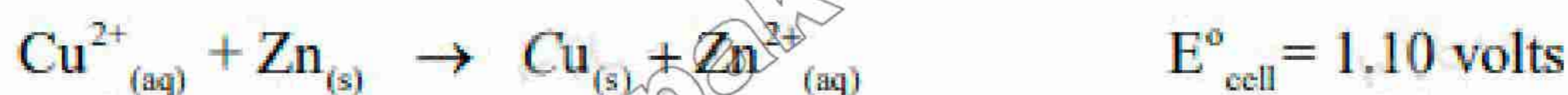

Q. How relative tendency of elements for redox reactions can be compared by using electrochemical series?

The value of the reduction potential of a metal or a nonmetal tells us the tendency to lose electrons and act as a reducing agent. It also gives the information about the tendency of a species to gain electrons and act as an oxidizing agent. Greater the value of standard reduction potential of a given species, greater is its tendency to accept electrons to undergo reduction and hence to act as an oxidizing agent.

Q. How can relative chemical reactivity of metals be compared by using electrochemical series?

Greater the value of standard reduction potential of a metal, smaller is its tendency to lose electrons to change into a positive ion and hence lower will be its reactivity. For example, metals like Li, Na, K and Rb are highly reactive. Coinage metals, Cu, Ag, and Au are the least reactive because they have positive reduction potentials.

Q. How reaction of metals with dilute acids can be compared by electrochemical series?

Greater the value of standard reduction potential of a metal, lesser is its tendency to lose electrons to form metal ions and so weaker is its tendency to displace H^{+} ions from acids as H_2 gas.

Modern Batteries and Fuel Cells

(All are important but Most Important are Mentioned)

Fuel Cells

In fuel cells H_2 is oxidized and O_2 is reduced. The electrolyte of the cell is aqueous KOH solution. Electrodes of the cell are made of porous carbon impregnated with platinum.

At Anode:



At Cathode:

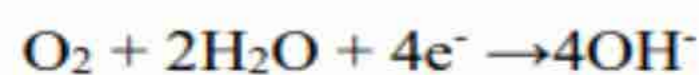

Overall reaction:

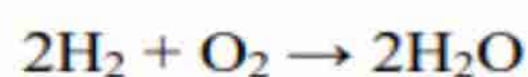

- Fuel cells are light, portable and produce electricity and pure water during space flights.
- These are environment friendly, efficient and convert about 75% fuel bond energy into electrical energy.

Lead Accumulator

Lead accumulator is a chargeable battery. The battery is chargeable the reactions of which can be reversed by applying external electrical source. **During the process of discharging, the density of H_2SO_4 decreases from 1.25 g cm^{-3} to 1.15 g cm^{-3} and volts drop down from 12V. After recharging the density of sulphuric acid again increases up to 1.25 g cm^{-3} , electrodes regain original physical states and cell restarts providing E.M.F of 12V.**

Discharging

At the anode the lead atoms release two electrons each to be oxidized to Pb^{2+} ions, which combine with SO_4^{2-} ions present in the electrolyte and get deposited on the anode as PbSO_4 .



During recharging the lead accumulator battery is connected to an external battery through the electrodes. As a result, the electrode half reactions are reversed as follows:



Both the density of the acid and voltage of the battery are restored.

Chapter 11

Reaction Kinetics

Q. Define reaction kinetics.

The studies concerned with rates of chemical reactions and the factors that affect the rates of chemical reactions constitute the subject matter of reaction kinetics.

Rate of reaction

Q. Define rate of reaction.

The rate of a reaction is defined as the change in concentration of a reactant or a product divided by the time taken for the change.

$$\text{Rate of reaction} = \frac{\text{change in concentration of the substance}}{\text{time taken for the change}}$$

$$\text{Rate of reaction} = \frac{\text{mol dm}^{-3}}{\text{seconds}} = \text{mol dm}^{-3} \text{ s}^{-1}$$

Q. What happens to rate of reaction with the passage of time?

The rate of reaction **decreases** with the passage of time.

Instantaneous and average rate

Q. Define instantaneous and average rate.

The rate at **any one instant** during the interval is called the **instantaneous rate**. The rate of reaction **between two specific time intervals** is called the **average rate of reaction**.

Law of mass action

Q. State law of mass action.

Rate of reaction is proportional to the active mass of the reactant or to the product of active masses if more than one reactants are involved in a chemical reaction.



$$\text{Rate of reaction} = [A]^a[B]^b$$

$$K_c = \frac{[C]^c[D]^d}{[A]^a[B]^b}$$

$$[A]^a[B]^b$$

Specific rate constant

Q. Define specific rate constant.

The specific rate constant of a chemical reaction is the rate of reaction when the **concentrations of the reactants are unity**.

If $[A] = 1 \text{ mol/dm}^3$ and $[B] = 1 \text{ mol/dm}^3$

Rate of reaction = $k \times 1^a \times 1^b$

Order of reaction

It is an experimentally determined value

Q. Define order of reaction. Give an example.

The order of reaction is given by the **sum of all the exponents** to which the concentrations **in the rate equation** are raised.

Decomposition of nitrogen pentoxide is a first order reaction.

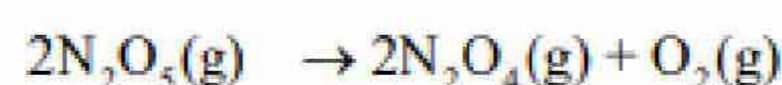

$$\text{Rate} = k[\text{N}_2\text{O}_5]$$

Other Examples (for Long question)

- **Hydrolysis of tertiary butyl bromide** is a **pseudo first order** reaction.

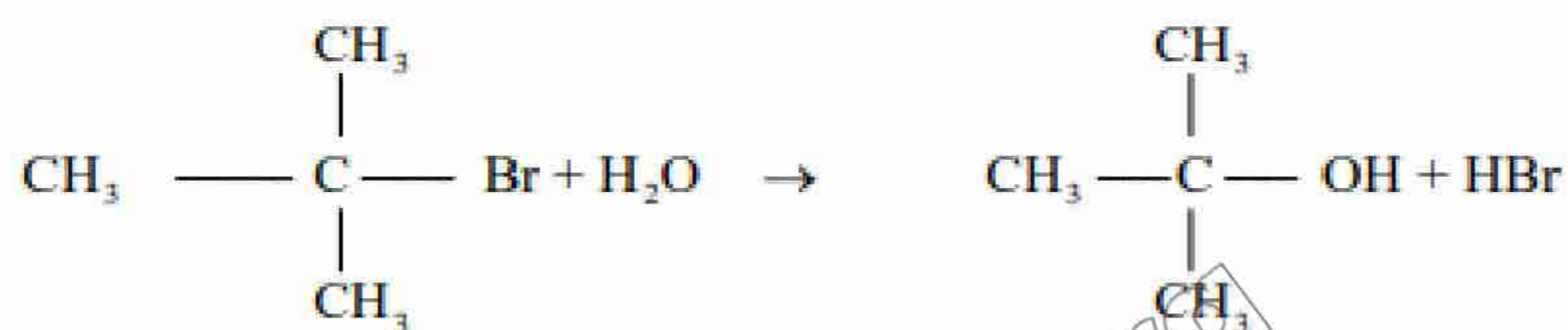

$$\text{Rate} = k[(\text{CH}_3)_3\text{CBr}]$$

- **Oxidation of nitric oxide** with ozone is **second order**.



$$\text{Rate} = k[\text{NO}][\text{O}_3]$$

- Order of reaction can be **fractional** also.



$$\text{Rate} = k[\text{CHCl}_3][\text{Cl}_2]^{1/2}$$

$$1 + 1/2 = 1.5 \text{ order}$$

- The reaction between **ferric chloride and potassium iodide** is a **third order reaction**.



$$\text{Rate} = [\text{FeCl}_3][\text{KI}]^2$$

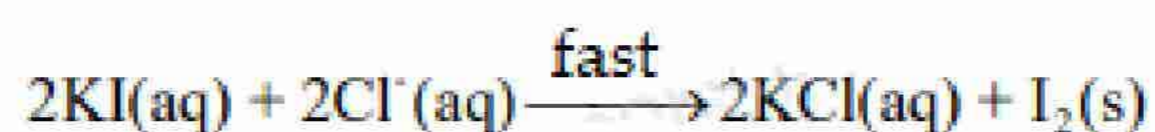

- A reaction is said to be **zero order** if it is entirely independent of the concentration of reactant molecules. **Photochemical reactions** are usually zero order.

Half Life Period

Q. Define half life period. Give an example.

Half life period of a reaction is the **time required** to convert **50% of the reactants into products**. For example, the half life period for the decomposition of N_2O_5 at 45°C is 24 minutes.

Q. The radioactive decay is always a first order reaction. Give reason.

The half-life period for the disintegration of a radioactive substance is independent of the amount of that substance. For example, the disintegration of radioactive U-235 has a half-life of 7.1×10^8 or 710 million years independent of its amount.

Q. Give the relation between half-life and initial concentration of reactant.

The relation between half-life and initial concentration of reactant can be expressed as:

$$[t_{1/2}]_1 \propto \frac{1}{a^0}, \text{ since } [t_{1/2}]_1 = \frac{0.693}{k}$$

$$[t_{1/2}]_2 \propto \frac{1}{a^1}, \text{ since } [t_{1/2}]_2 = \frac{1}{k_a}$$

$$[t_{1/2}]_3 \propto \frac{1}{a^2}, \text{ since } [t_{1/2}]_3 = \frac{1.5}{ka^2}$$

For the reaction of n^{th} order

$$[t_{1/2}]_n \propto \frac{1}{a^{n-1}}$$

Rate Determining Step

Q. Give the relation between half-life and initial concentration of reactant.

The **slowest step** in the reaction is the rate determining step.

For example,



The reaction is done in two steps:

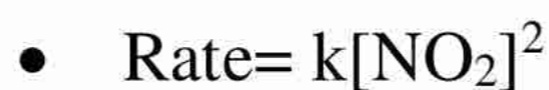
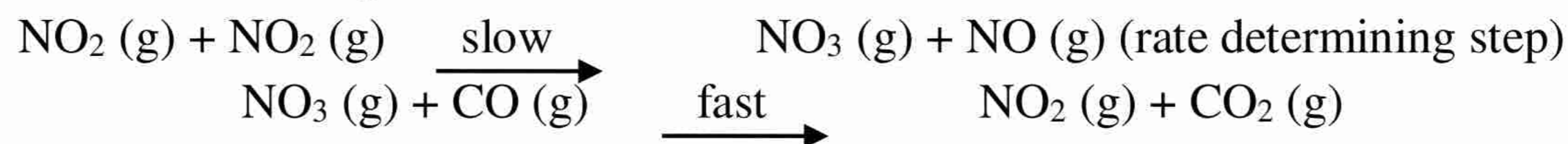

NO_3 is reaction intermediate. It has a **temporary existence** and it is **unstable** relative to the reactants and the products.

Physical Methods for Determining Rate of Reaction

- Spectrometry
- Electrical conductivity method
- Dilatometric method
- Refractometric method
- Optical rotation method

Chemical Method for Determining Rate of Reaction

This is suitable for reactions in solution. In this method, we do the chemical analysis of a reactant or a product.

For example,

The acid hydrolysis of an ester (ethyl acetate) in the presence of a small amount of an acid.



Energy of Activation

Q. Define energy of activation.

The **minimum amount of energy** required for an effective collision is called activation energy.

Activated Complex

Q. Define activated complex.

An **unstable combination of all the atoms** involved in the reaction for which the **energy is maximum**. It is a **short lived species** and decomposes into the products immediately. It has a **transient existence** so also called a **transition state**.

Potential Energy Diagrams

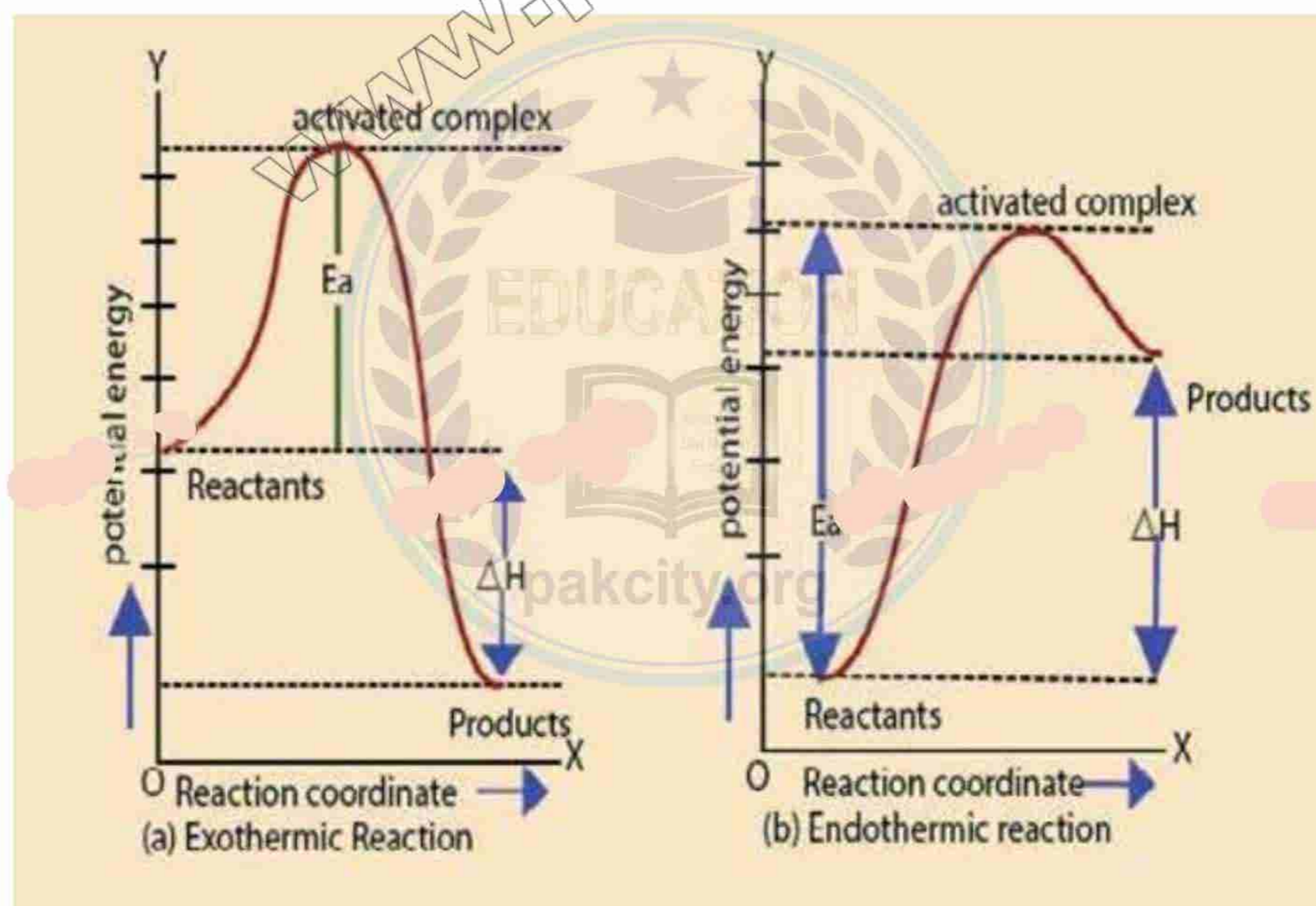

Methods to Determine Order of Reaction

(Learn for Short Questions and Answer to Long Question)

It can be determined by the following methods:

1. Method of hit and trial 2. Graphical method 3. Differential method 4. Half life method
5. Method of large excess

Half-life method

$$n-1 = \frac{\log \left[\frac{t_1}{t_2} \right]}{\log \left[\frac{a_2}{a_1} \right]}$$

$$n = 1 + \frac{\log \left[\frac{t_1}{t_2} \right]}{\log \left[\frac{a_2}{a_1} \right]}$$

If we know the two initial concentrations and two half life values we can calculate the order of reaction (n).

Method of large excess

One of the reactants is taken in a very small amount. The active masses of the substances in large excess remain constant. That substance taken in small amount controls the rate and the order is noted.

Factors Affecting Rates of Reaction

(Learn for Short Questions and Answer to Long Question)

1. Nature of reactants

IA members having one electron in outermost shell **react rapidly with water than IIA members** having two electrons in outermost shell.

The neutralization and double decomposition reactions are very fast as compared to bond rearrangements.

Oxidation-reduction reactions slower than ionic reactions.

2. Concentration of reactants

An increase in the concentrations of the reactants will result in the corresponding increase in the reaction rate as effective collisions increase. **For example, combustion that occurs slowly in air (21 % oxygen) will occur more rapidly in pure oxygen.**

3. Surface area

Greater the surface area more is the rate of reaction. **For example, CaCO₃ in the powdered form reacts with dilute H₂SO₄ more efficiently than its big pieces.**

4. Light

As the intensity of light increases the rate of reaction increases. **For example, the reaction between H₂ and Cl₂ is negligible in darkness, slow in daylight, but explosive in sunlight.**

Effect of Temperature on Rate of Reaction

Q. What is the effect of temperature on rate of reaction?

Temperature increases the number of collisions so the **rate of reaction increases with increasing temperature**.

Arrhenius Equation

Q. What is the effect of temperature on rate constant of a reaction?

Arrhenius equation explains the effect of temperature on the rate constant of a reaction.

According to Arrhenius:

$$k = Ae^{-E_a/RT}$$

'k' is exponentially related to activation energy (E_a) and temperature (T). R is general gas constant and e is the base of natural logarithm.

Catalysis

Q. Define catalyst and catalysis.

A catalyst is a substance which **alters the rate of a chemical reaction** but remains chemically unchanged at the end of the reaction. The **process** is called **catalysis**.

Examples

The reaction between **H₂ and O₂ to form water** proceeds rapidly in the presence of **platinum**.

KClO₃ decomposes rapidly in the presence of **MnO₂**.

HCl is oxidized to Cl₂ in the presence of **CuCl₂**.

Q. What are the types of catalysis? OR What is the difference between homogeneous catalysis and heterogeneous catalysis?

Homogeneous catalysis

The catalyst and the reactants are in the **same phase**.

For example,



Heterogeneous catalysis

The catalyst and the reactants are in **different phases**.

For example,



Characteristics of a catalyst

(Learn for short question and long question)

Following are the characteristics of a catalyst:

1. A **catalyst remains unchanged** at the end of reaction.

2. A **trace of a metal catalyst needed** to affect large amount of reactants.
3. A catalyst is **more effective in a finely divided form**.
4. A **catalyst cannot affect K_c of a reaction** but it establishes equilibrium earlier.
5. A catalyst **cannot start a reaction not thermodynamically feasible**.
6. The **mechanism of a catalyzed reaction is different** from that of an uncatalyzed reaction.

Activation of catalyst

Q. Define promotor or activator.

Such a substance which promotes the activity of a catalyst is called a promotor or activator. It is also called "**catalyst for a catalyst**".

Examples

1. Hydrogenation of vegetable oils

Catalyst: nickel

Activator: copper and tellurium

2. Manufacture of ammonia (Haber's process)

Catalyst: iron

Activator: Aluminum oxide, chromium oxide or rare earth oxides.

Negative Catalysis

Q. Define negative catalysis

When the **rate of reaction is retarded by adding a substance**, then it is said to be a negative catalyst or inhibitor.

- (i) **Tetraethyl lead** saves the **petrol from pre-ignition**.
- (ii) The presence of **CO with hydrogen inhibits catalyst in the Haber's process**.
- (iii) **The manufacture of H_2SO_4 in the contact process needs platinum catalyst and arsenic is inhibitor**.

Autocatalyst

Q. Define autocatalyst.

In some of the reactions, **a product formed acts as a catalyst**. This phenomenon is called **autocatalysis**.

Examples

- i. Reaction of **copper with nitric acid** is accelerated by the formation of **nitrous acid**.
- ii. The reaction of **oxalic acid with acidified $KMnO_4$** is accelerated by **$MnSO_4$** produced.

Enzyme Catalysis

(Learn for short question and long question)

Enzymes are the complex protein molecules and catalyze the organic reactions in the living cells.

Examples

- (i) Urease for urea hydrolysis
- (ii) Invertase for sugar hydrolysis to glucose and fructose
- (iii) Zymase for conversion of glucose to ethanol

Lock and Key Model

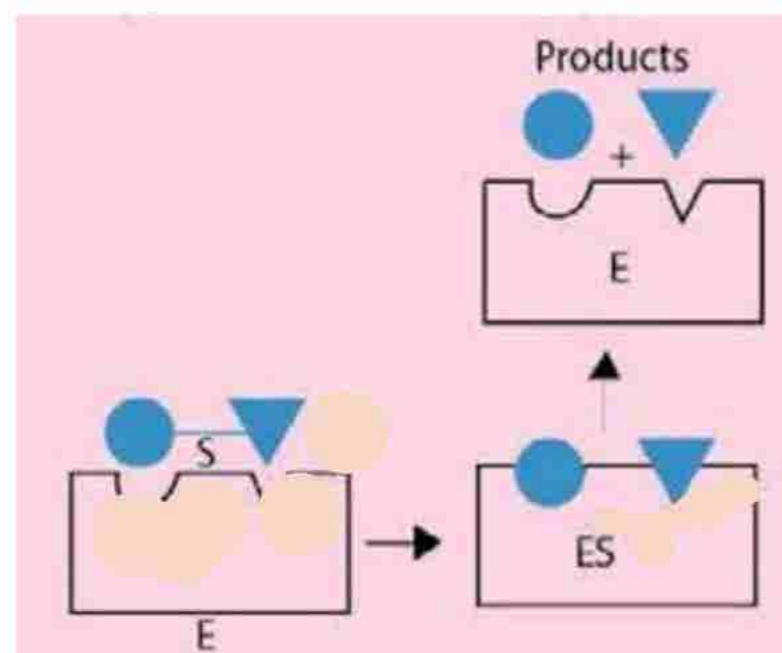

E= Enzyme, S= Substrate, ES= Activated complex, P= Product

Characteristics of Enzyme Catalysis

- (i) Most efficient catalysts known.
- (ii) They lower the energy of activation of a reaction.
- (iii) Enzymes catalysis is highly specific.
- (iii) Enzyme catalytic reactions have the maximum rates at an optimum temperature and pH.
- (iv) The activity of enzyme catalyst is inhibited by a poison.
- (v) The catalytic activity of enzymes is enhanced by the presence of a co-enzyme or activator.

