

Dear Students,

Definitions make up an important portion of the F.Sc. Part I Chemistry paper. An effort has been made to compile these definitions into a booklet so that students who struggle to pass the exam may never fail. By learning these definitions, students will be able to secure 14-16 marks, as definitions come as separate short questions or as a part of the long questions.

We wish you all the very best in your struggle to gain good marks.

God bless



Table of Contents

Chapter	Page No.
1	1-2
2	3-5
3	6-9
4	10-15
5	16-19
6	20-23
7	24-26
8	27-29
9	30-33
10	34-35
11	36-38



CHAPTER 1

Basic Concepts

DEFINITIONS

Give definitions of the following terms:

1. Relative atomic mass

Relative atomic mass is the mass of an atom of an element as compared to the mass of an atom of carbon taken as 12. For example, the relative atomic mass of hydrogen is 1.008 amu and that of oxygen is 15.9994 amu.

2. Isotopes

Isotopes are the atoms of an element having same atomic number but different mass numbers. For example, carbon has three isotopes i.e. C-12, C-13 and C-14, hydrogen has three isotopes i.e. H-1, H-2, H-3, oxygen has three isotopes i.e. O-16, O-17, O-18 etc.

3. Mass spectrometer

Mass spectrometer is an instrument which is used to measure the exact masses of different isotopes of an element.

4. Mass spectrum

Mass spectrum is the plot of data in such a way that (m/e) is plotted as abscissa (x-axis) and the relative abundance of ions as ordinate (y-axis).

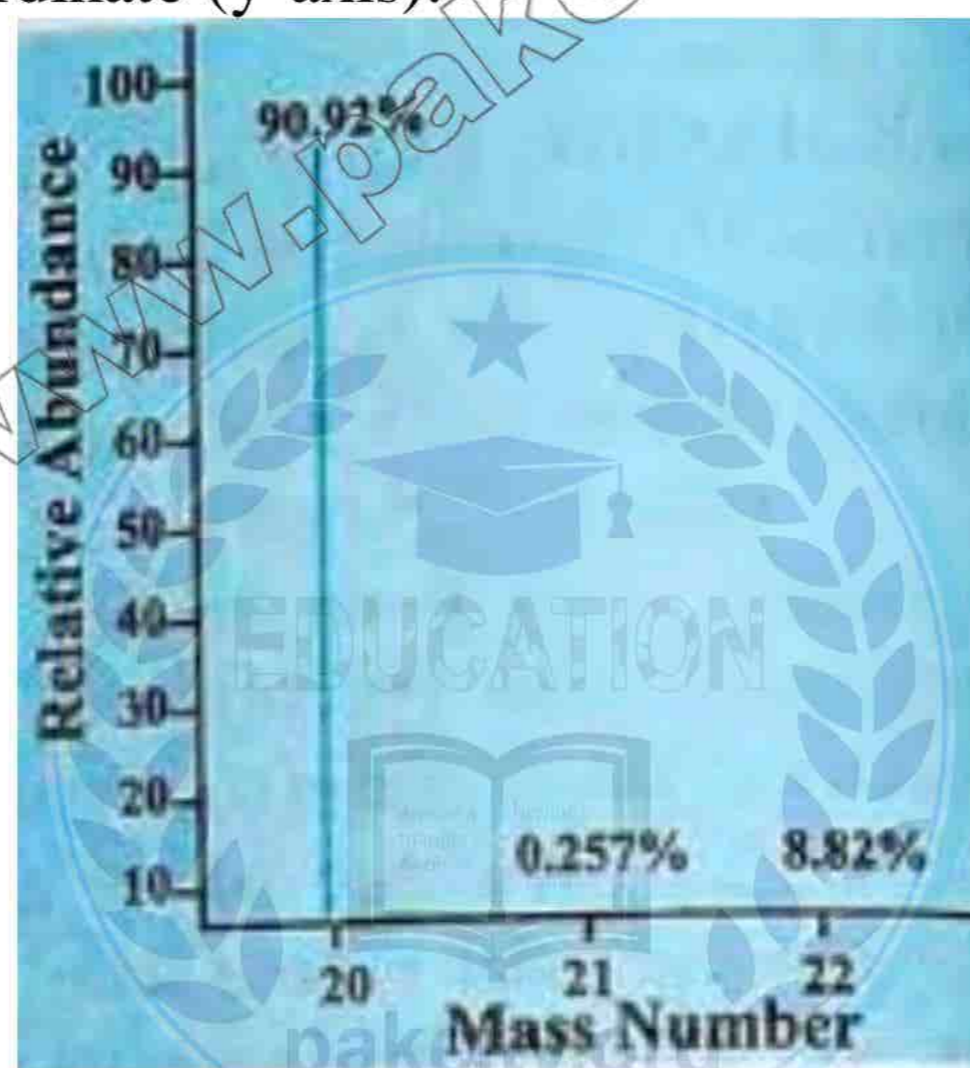

Mass spectrum of Neon

5. Empirical Formula

The formula that gives the simplest whole number ratio of atoms of different elements present in one molecule of a compound is called empirical formula. For example, CH is empirical formula of C_6H_6 and CH_2O is empirical formula of $C_6H_{12}O_6$.

6. Molecular Formula

The formula that gives the exact number of atoms of different elements present in one molecule of a compound is called molecular formula. For example, C_6H_6 is molecular formula of benzene and $C_6H_{12}O_6$ is molecular formula of glucose.

7. Mole

The atomic mass, molecular mass, formula mass or ionic mass of the substance expressed in grams is called molar mass of the substance. It is expressed as:

$$\text{Number of moles} = \frac{\text{Given Mass in Grams}}{\text{Molar mass in grams per mole}}$$

For example, 1 gram atom of hydrogen = 1.008 g, 1 gram atom of water = 18 g, 1 gram formula of NaCl = 58.5 g, 1 g ion of OH⁻ = 17 g

8. Avogadro's Number

Avogadro's number is the number of atoms, molecules and ions in one gram atom of an element, one gram molecule of a compound and one gram ion of a substance, respectively. For example, 1.008 g of hydrogen = 1 mole of hydrogen = 6.02×10^{23} atoms of H, 18 g of H₂O = 1 mole of water = 6.02×10^{23} molecules of water, 96 g of SO₄²⁻ = 1 mole of SO₄²⁻ = 6.02×10^{23} ions of SO₄²⁻.

9. Molar volume

One mole of any gas at standard temperature and pressure (STP) occupies a volume of 22.414 dm³. This volume of 22.414 dm³ is called molar volume and it is true only when the gas is ideal. For example, 2.016 g of H₂ = 1 mole of H₂ = 6.02×10^{23} molecules of H₂ = 22.414 dm³ of H₂ at STP, 16 g of CH₄ = 1 mole of CH₄ = 6.02×10^{23} molecules of CH₄ = 22.414 dm³ of CH₄ at STP.

10. Stoichiometry

Stoichiometry is a branch of chemistry which tells us the quantitative relationship between reactants and products in a balanced chemical equation. For example,

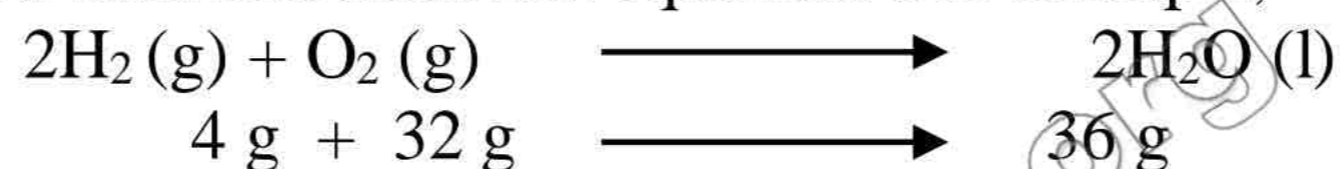

11. Limiting Reactant

The limiting reactant is a reactant that controls the amount of the product formed in a chemical reaction due to its smaller amount. For example,



According to the balanced equation, 2 moles of hydrogen (4 g) react with 1 mole of oxygen (16 g) to give 2 moles of water (36 g). As hydrogen is present in small amount so it is the limiting reactant.

12. Actual Yield

The amount of the products obtained in a chemical reaction is called the actual yield of that reaction. It is also called experimental yield. Actual yield is lesser than the theoretical yield.

13. Theoretical Yield

The amount of the products obtained from balanced chemical equation is called theoretical yield of reaction.

14. Percentage Yield/Efficiency of a Reaction

The efficiency of a reaction is expressed by comparing the actual and theoretical yields in the form of percentage (%) yield.

$$\% \text{ yield} = \frac{\text{Actual yield}}{\text{Theoretical yield}} \times 100$$

CHAPTER 2

Experimental Techniques in Chemistry

DEFINITIONS

Give definitions of the following terms with examples:

1. Analytical Chemistry

Analytical chemistry is the science of chemical characterization. It includes two steps:

- a. Qualitative analysis
- b. Quantitative analysis

2. Qualitative Analysis

In qualitative analysis, the chemist is concerned with the detection or identification of the elements present in a compound. For example, in $C_6H_{12}O_6$ the detection of presence of carbon, hydrogen and oxygen is qualitative analysis of the compound.

3. Quantitative Analysis

In quantitative analysis, the relative amounts of the elements are determined. For example, in $C_6H_{12}O_6$ the ratio of C:H:O is 6:12:6 or 1:2:1.

4. Filtration

The process of filtration is used to separate insoluble particles from liquids. For example, separation of sand and salt solution through filter paper.

5. Residue

The material left on top of the filter paper after filtration (which cannot pass through the pores of filter paper) is called residue. For example, in separation of sand and salt solution, sand being insoluble in water and impermeable through the pores of filter paper remains on top of it.

6. Filtrate

The part of the solution which easily passes through pores of the filter paper is called filtrate. For example, in separation of sand and salt solution, the water carrying dissolved salt in it passes easily through the filter paper making filtrate.

7. Fluted Filter Paper

When an ordinary filter paper is folded in such a way that a fan like arrangement with alternate elevations and depressions at various folds is obtained then it is called fluted filter paper.

8. Gooch Crucible

Gooch crucible is made up of porcelain with perforations at the base which are further covered with paper pulp or a filter paper cut to its size. It is placed in a suction filtering apparatus to increase the rate of filtration. Use of gooch crucible assists in filtration of precipitates which are supposed to be ignited at high temperature. Where concentrated HCl and $KMnO_4$ are used asbestos mat replaces filter paper.

9. Sintered glass crucible

In sintered glass crucible, a porous glass disc is sealed into the bottom. As there is no preparation required, like that needed in gooch crucible, it is convenient to use it.

10. Crystallization

Crystallization is the removal of a solid from solution by increasing its concentration above the saturation point in such a manner that the excess solid separates out in the form of crystals. For example, crystallization of CuSO_4 and benzoic acid from water.

11. Sublimation

It is a process in which a solid, when heated, vapourizes directly without passing through the liquid phase and these vapours can be condensed to form the solid again. The purpose of sublimation is to purify a solid. For example, ammonium chloride, iodine, naphthalene, benzoic acid etc are sublimates.

12. Solvent Extraction

According to solvent extraction a solute can be separated from a solution by shaking the solution with a solvent in which the solute is more soluble and the added solvent does not mix with the solution. For example, ether extraction.

13. Distribution law/Partition law

Solvent extraction is an equilibrium process and follows the distribution law or partition law. This law states that a solute distributes itself between two immiscible liquids in a constant ratio of concentrations irrespective of the amount of solute added.

14. Chromatography

Chromatography originates from the Greek word "Khromatos" meaning colour writing. It is a method used for the separation of the components of a mixture sample between stationary phase and mobile phase. For example, paper chromatography.

15. Stationary phase

The stationary phase may be a solid or a liquid supported as a thin film on the surface of an inert solid. For example, filter paper strips in paper chromatography.

16. Mobile phase

Mobile phase flows over the surface of the stationary phase. It may be a liquid or a gas. For example, water, ethanol etc.

17. Adsorption chromatography

Chromatography in which the stationary phase is a solid is termed as adsorption chromatography. For example, TLC (thin layer chromatography).

18. Partition chromatography

Chromatography in which the stationary phase is a liquid is termed as partition chromatography. For example, paper chromatography.

19. Retardation factor

It is the ratio of the distance travelled by a component from the original spot to the distance travelled by solvent from the original spot. It is denoted by R_f . As it is a ratio between similar quantities so it has no units.

$$R_f = \frac{\text{Distance travelled by a component from the original spot}}{\text{Distance travelled by solvent from the original spot}}$$

20. Distribution coefficient (K)

It is the ratio of the concentration of solute between two immiscible liquids at equilibrium. No matter how much solute is added, the ratio of the final concentrations at equilibrium is constant. The constant is called distribution coefficient K and is given by:

$$K = \frac{[\text{I}_2(\text{CCl}_4)]}{[\text{I}_2(\text{aq})]}$$

In chromatography, the distribution of the components of a mixture between the two phases is governed by distribution coefficient K.

$$K = \frac{\text{Concentration of a component in the moving phase}}{\text{Concentration of that component in the stationary phase}}$$



CHAPTER 3

Gases

DEFINITIONS

Give definitions of the following terms:

1. Atmospheric pressure

The pressure of air that can support 760 mm Hg column at sea level is called one atmosphere. It is the force exerted by 760 mm or 76 cm long column of mercury on an area of 1 cm² at 0 °C. It is the average pressure of atmosphere at sea level.

2. Gas Laws

The relationships between volume of a given amount of gas and the prevailing conditions of temperature and pressure are called the gas laws. Examples are Boyle's law, Charles's law, Graham's law, Dalton's law and Avogadro's law.

3. Boyle's Law

The volume of a given mass of a gas at constant temperature is inversely proportional to the pressure applied to the gas.

$$V \propto \frac{1}{P} \text{ (when temperature and number of moles are constant)}$$

$$V = \frac{k}{P}$$

$$PV = k \text{ (when } T \text{ and } n \text{ are constant)} \dots \dots (1)$$

'k' is proportionality constant. Its value depends upon the amount of gas.

From eq (1) another definition of Boyle's law can be given as follows:

The product of pressure and volume of a fixed amount of a gas at constant temperature is a constant quantity.

$$\text{So, } P_1V_1 = k \text{ and } P_2V_2 = k$$

$$\text{Hence, } P_1V_1 = P_2V_2$$

4. Charles's Law

The volume of the given mass of a gas is directly proportional to the absolute temperature when the pressure is kept constant.

$$V \propto T \text{ (when pressure and number of moles are constant)}$$

$$V = kT$$

$$\frac{V}{T} = k$$

T

If the temperature is changed from T₁ to T₂ and volume changes from V₁ to V₂ then

$$\frac{V_1}{T_1} = k \text{ and } \frac{V_2}{T_2} = k$$

The ratio of volume to temperature remains constant for same amount of gas at same pressure.

5. Quantitative definition of Charles's Law

At constant pressure, the volume of the given mass of a gas increases or decreases by 1/273 of its original volume at 0°C for every 1°C rise or fall in temperature respectively.

6. Absolute Zero

The temperature -273.16°C or 0 K is called absolute zero. This is a hypothetical temperature. It is the lowest possible temperature which a gas can attain while remaining in the gaseous state. This

temperature is impossible to be attained by real gases because attractive forces develop at low temperature and they get converted to liquid or solid even before reaching this temperature. Motion of the gas molecules ceases at such a low temperature.

7. Centigrade Scale

It has a zero mark for the temperature of ice at one atmospheric pressure. The mark 100°C indicates the temperature of boiling water at 1 atmospheric pressure. The space between these temperature marks is divided into 100 equal parts and each part is 1°C.

8. Fahrenheit Scale

The melting point of ice at 1 atmospheric pressure has a mark of 32°F and that of boiling water is 212°F. The space between these temperature marks is divided into 180 equal parts and each part is 1°F.

9. Absolute or Kelvin Scale

The melting point of ice at 1 atmospheric pressure is 273 K. The water boils at 373 K or more precisely at 373.16 K.

10. Avogadro's Law

Equal volumes of all the ideal gases at the same temperature and pressure contain equal number of molecules.

Example: If we have one dm³ of each of H₂, He, N₂, O₂ and CO in separate vessels at STP, then the number of molecules in each will be 2.68 × 10²². This is obtained by dividing 6.02 × 10²³ with 22.414 dm³.

11. Dalton's Law of Partial Pressures

The total pressure exerted by a mixture of non-reacting gases is equal to the sum of their individual partial pressures.

Let the gases be 1,2,3 and their partial pressures be p₁, p₂, p₃. The total pressure (P_t) of the mixture of gases is given by:

$$P_t = p_1 + p_2 + p_3$$

12. Aqueous tension

The pressure of vapours of water at a particular temperature is called aqueous tension. Water vapours are always present in the air and exert pressure.

13. Diffusion

The spontaneous mixing of the molecules of different gases by random motion and collision to form homogeneous mixture is called diffusion. Example, spreading of flower fragrance.

14. Effusion

The passage of gas molecules one by one without collision through a pinhole in a container into an evacuated space is called effusion. Example, escape of gas from a punctured tyre.

15. Graham's law of diffusion

The rate of diffusion or effusion of a gas is inversely proportional to the square root of its density at constant temperature and pressure

$$\text{Rate of diffusion} \propto \frac{1}{d} \text{ (at constant temperature and pressure)}$$

$$\text{Rate of diffusion} = \frac{k}{d}$$

$$\text{Rate of diffusion} \times d = k$$

$$\text{or Rate} \times d = k$$

For two gases 1 and 2

$$r_1/r_2 = d_2/d_1$$

Density is proportional to mass so

$$r_1/r_2 = M_2/M_1$$

16. Critical Temperature

The highest temperature at which a substance can exist as a liquid is called its critical temperature (T_c). Example, oxygen has critical temperature of 154.4 K (-118.75°C).

17. Critical Pressure

The minimum pressure which is required to liquefy a gas at its critical temperature is called critical pressure (P_c). Example, oxygen has critical pressure 49.7 atm.

18. Critical Volume

The volume which is occupied by one mole of a gas at critical temperature and critical pressure is called critical volume (V_c). Example, critical volume of oxygen is 74.42 cm³ mol⁻¹.

19. Joule Thomson Effect

When a compressed gas is allowed to expand into a region of low pressure it gets cooled.

20. Liquefaction

The process of conversion of a gaseous substance into the liquid state is called liquefaction of the gas.

21. Plasma

The ionized gas mixture, consisting of ions, electrons and neutral atoms is called plasma. Plasma is a distinct state of matter containing a significant number of electrically charged particles a number sufficient to affect its electrical properties and behaviour.

22. Van der Waal's constants

Van der Waal has proposed two constants as "a" and "b" for real gases. The constant "a" stands for the measurement of forces of attractions among the molecules of a gas. The constant "b" stands for the excluded volume of the gas. Their units are atm dm⁶ mol⁻² and dm³ mol⁻¹ respectively.

23. Ideal Gas

That gas which obeys gas laws like Boyle's law, Charles's law and Avogadro's law is called ideal gas. The ideal gas should obey the general gas equation i.e., $PV = nRT$

24. Non-ideal Gas

That gas which does not obey the gas laws under all conditions of temperature and pressure is called a non-ideal gas. The general gas equation $PV = nRT$ is not obeyed completely.

25. Mole fraction of gas

It is ratio of number of moles of a gas to the total number of moles of all the gases in the mixture.

$$X_1 = n_1/n_1+n_2+n_3$$

26. Mean square velocity

It is the average of the squares of all the possible velocities of gas molecules.

$$c^2 = \frac{c_1^2 + c_2^2 + c_3^2 + \dots + c_n^2}{n}$$

27. Root mean square velocity

It is a square root of mean square velocity of a gas

$$C_{rms} = \sqrt{3RT/M}$$

28. Partial pressure

The pressure which is exerted by an individual gas in a gaseous mixture is called partial pressure of that gas.

$$p_i = X_i P_t$$

29. Triple point

The temperature where three states of a substance coexist is called the triple point

30. Isotherm

A graph between pressure and volume of the gas at constant temperature and the number of moles is called isotherm. It is a parabolic curve, It is in the shape of a curve.



CHAPTER 4

Liquids and Solids

DEFINITIONS

Give definitions of the following terms:

LIQUIDS

1. Intermolecular Forces

The forces which hold the molecules together are called intermolecular forces. For example,

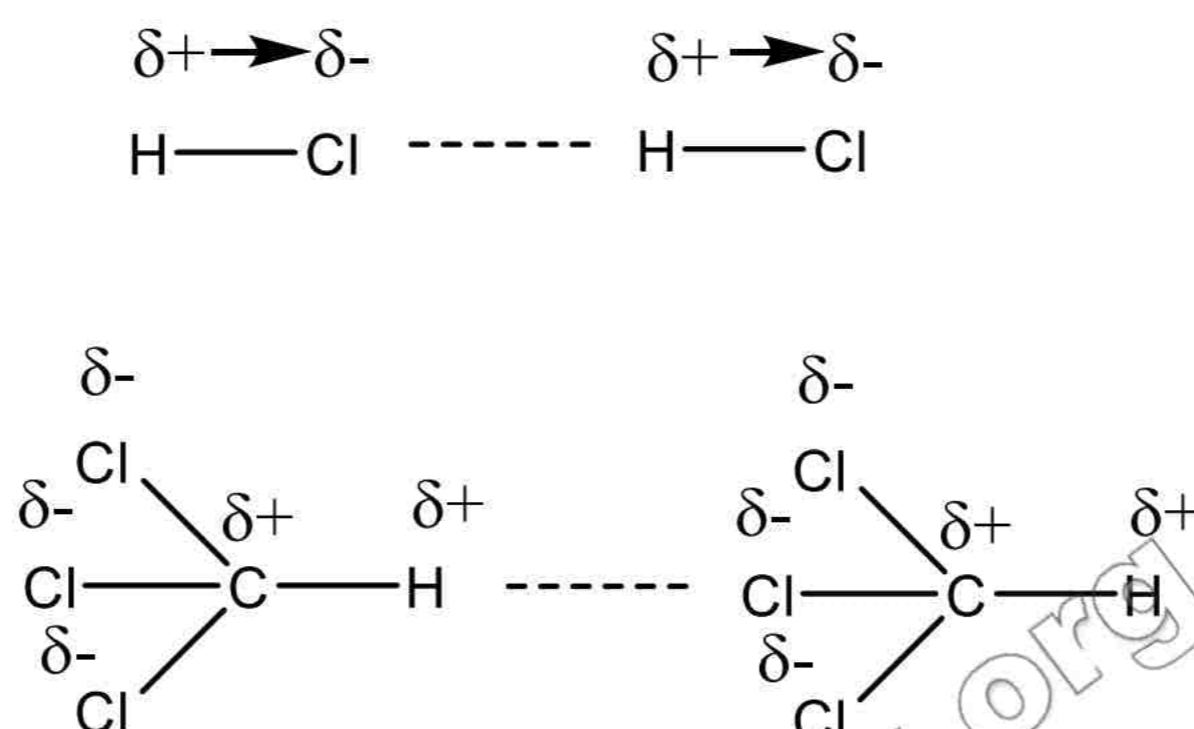

Dotted lines show intermolecular forces

2. Intramolecular Forces

The forces of attraction within the molecule are called intramolecular forces. For example,

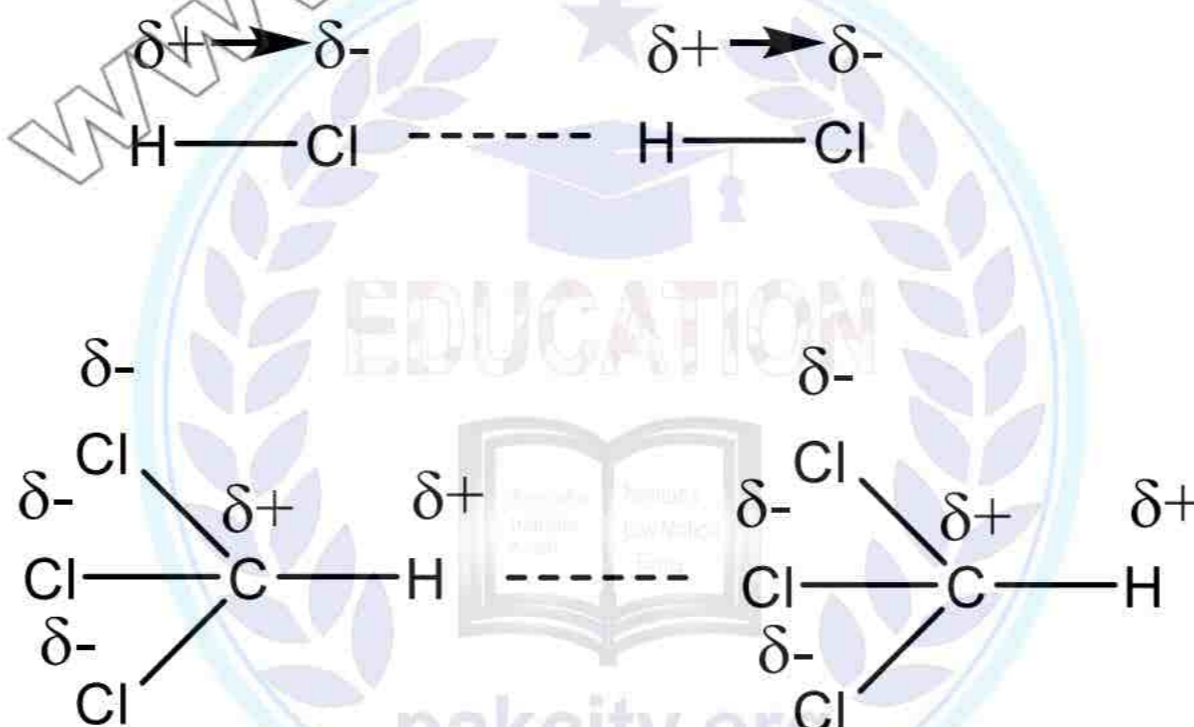

Solid lines show intramolecular forces

3. Dipole-dipole Forces

The positive end of one molecule attracts the negative end of the other molecule and these electrostatic forces of attraction are called dipole-dipole forces. For example,

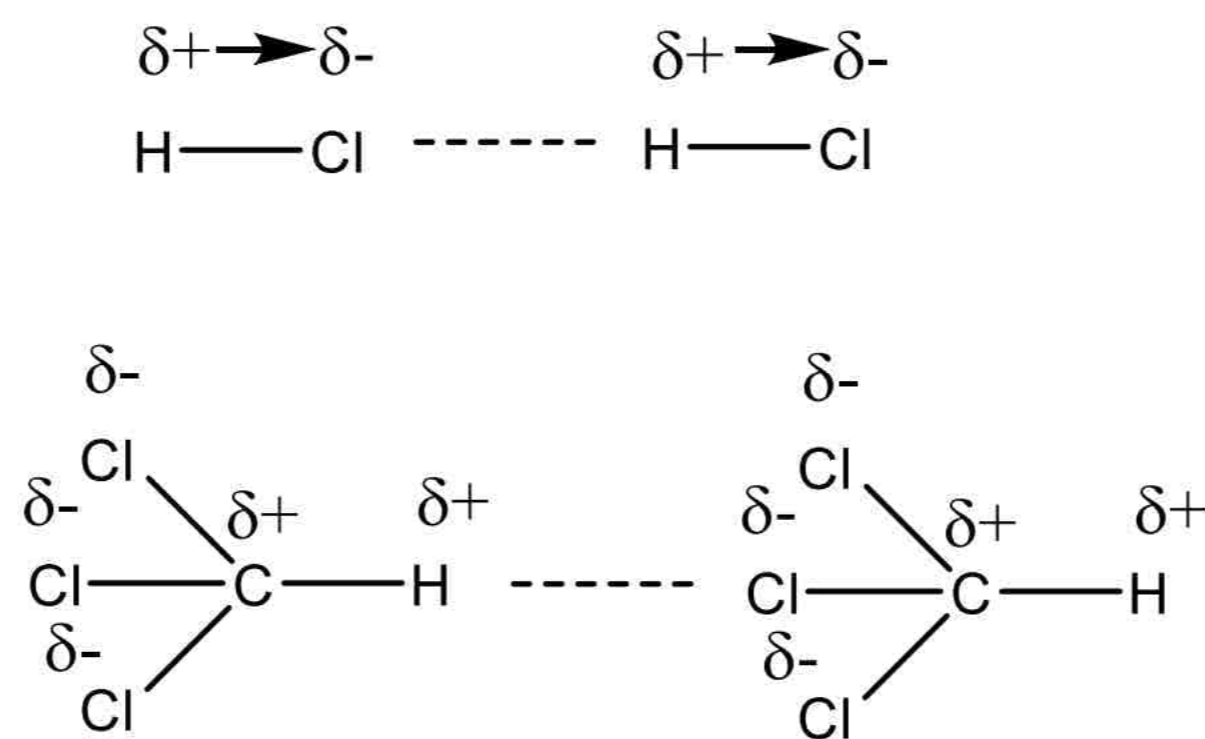

4. Dipole-induced dipole Forces

Those forces of attractions which exist between already polar molecules and the molecule having induced polarity.

5. Ion-dipole Forces

The forces of attraction between an ion and a dipole are called ion-dipole forces.

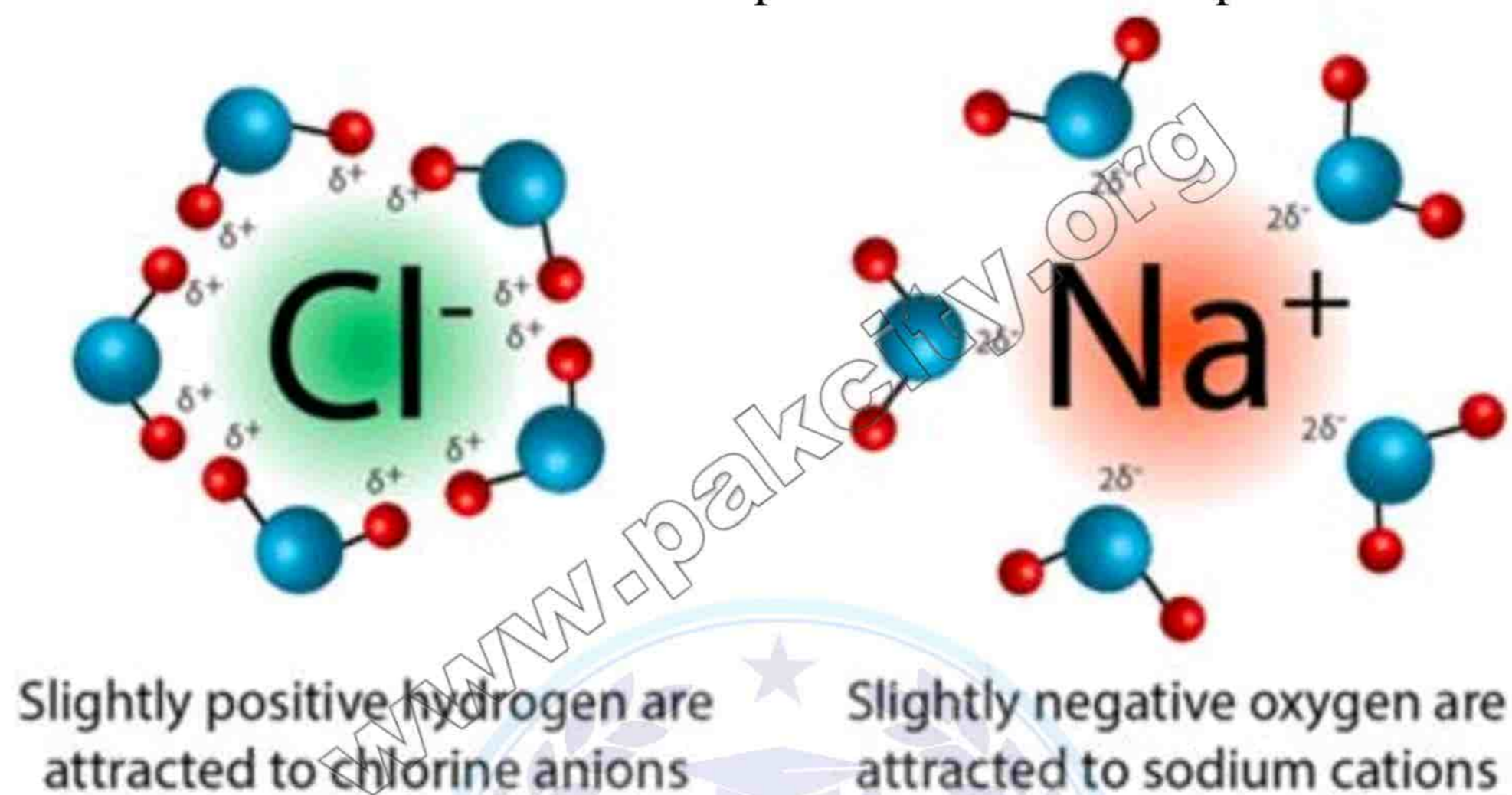

6. Dipole

It is that molecule which has two poles in it. These poles are created due to the difference of electronegativities. HCl has dipoles. H is partial positive while Cl is partial negative.

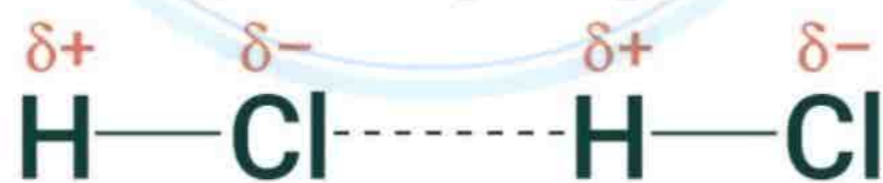

7. Instantaneous Dipole-Induced Dipole Forces or London Dispersion Forces

The momentary force of attraction created between instantaneous dipole and the induced dipole is called dipole-induced dipole interaction or London forces. Example, this type of interaction is seen in Cl_2 , H_2 and noble gases (helium, neon etc.)

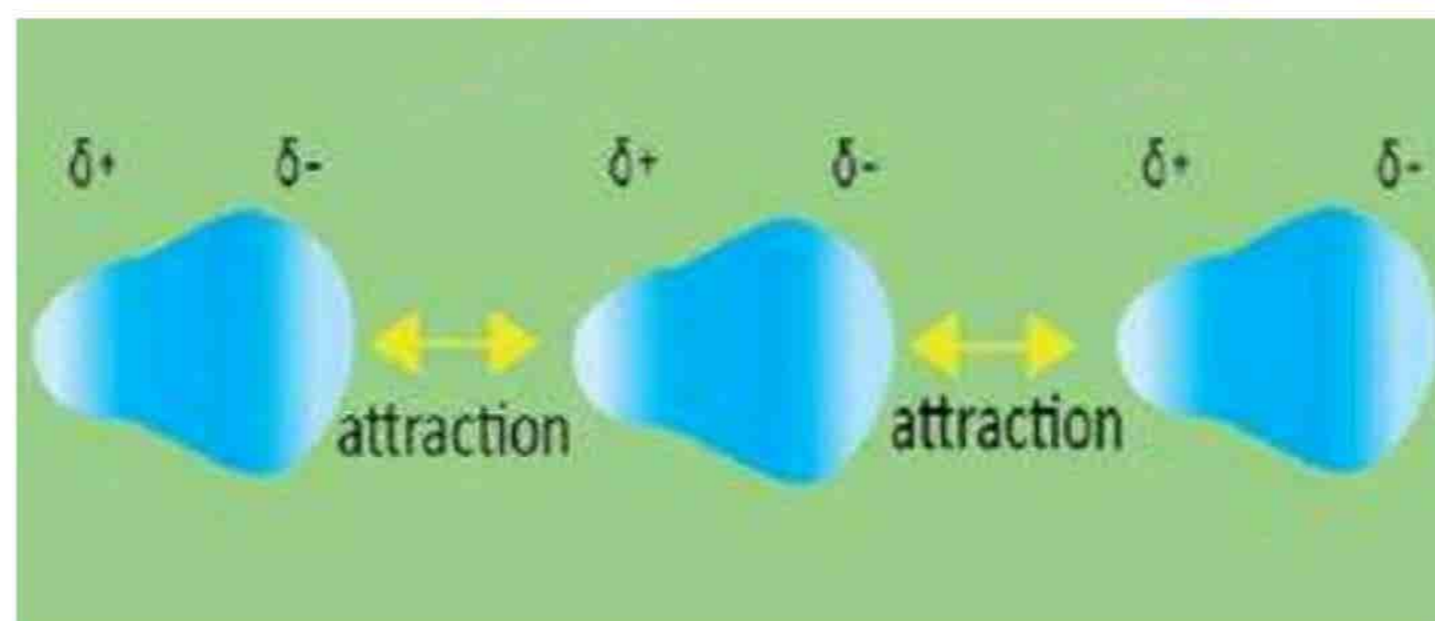

8. Boiling Point

The temperature at which the vapour pressure of a liquid becomes equal to the atmospheric pressure. For example, boiling point of water is 100°C.

9. Polarizability

It is the quantitative measurement of the extent to which the electronic cloud can be polarized or distorted.

10. Instantaneous dipole

The temporary dipole which is produced in non-polar atoms or molecules due to a certain reason. Non-polar gaseous molecules create instantaneous dipoles. Helium is best example.

11. Induced Dipole

A molecule in which polarity is created due to other polar molecule is called induced dipole. For example, HCl induces polarity in noble gases if in mixture.

12. Hydrogen bonding

Hydrogen bonding is the electrostatic force of attraction between a highly electronegative atom (F, N, O) and partial positively charged hydrogen atom. For example, water

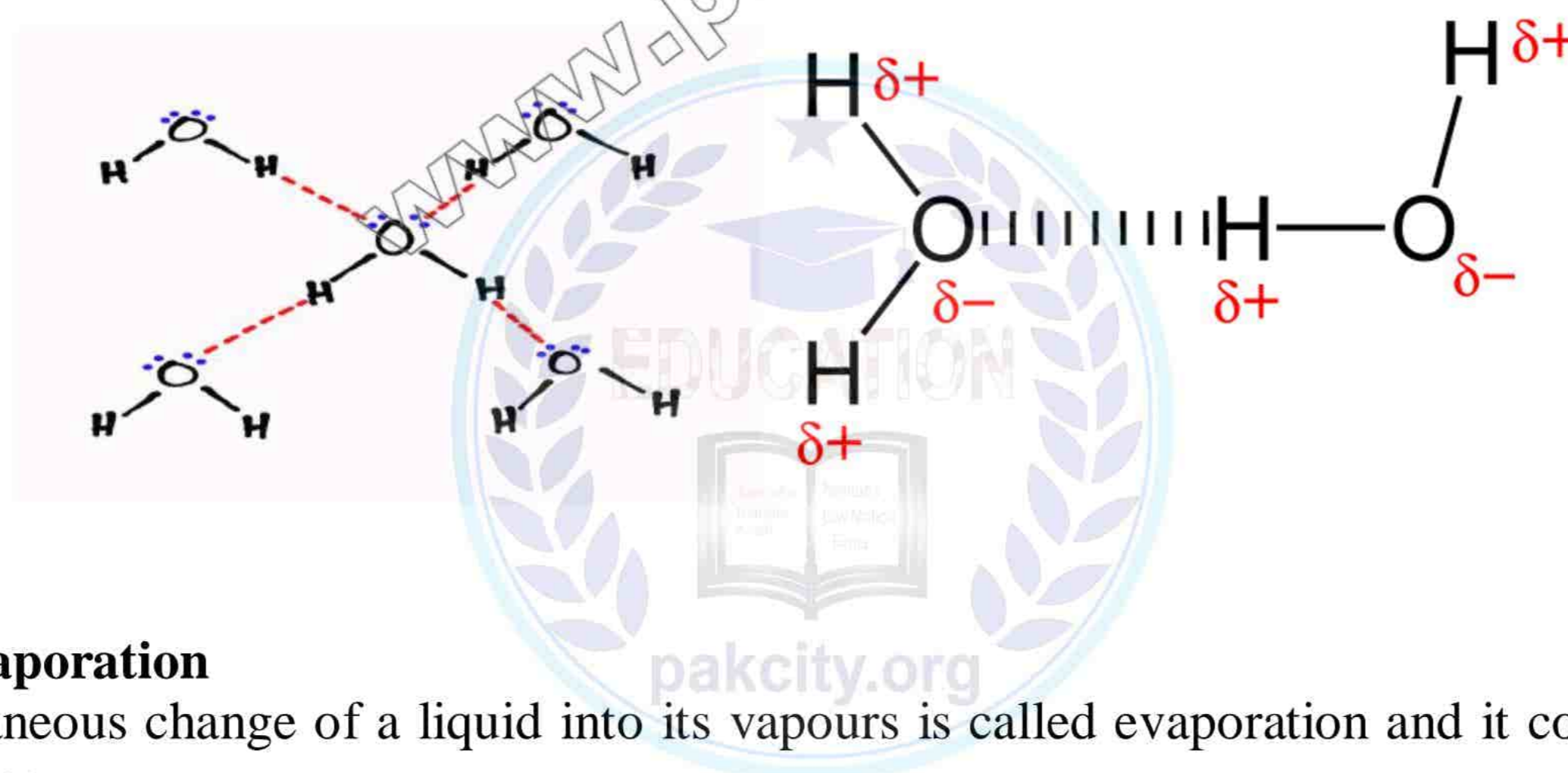

13. Evaporation

The spontaneous change of a liquid into its vapours is called evaporation and it continues at all temperatures.

14. Vapour pressure

The vapour pressure of a liquid is a pressure exerted by the vapours of the liquid in equilibrium with the liquid at a given temperature.

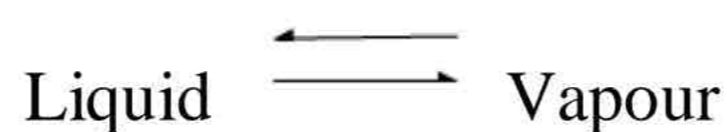

15. Molar Heat of Fusion (ΔH_f)

It is the amount of heat absorbed by one mole of a solid when it melts into liquid form at its melting point. The pressure during the change is kept one atmosphere.

16. Molar Heat of Vapourization (ΔH_v)

It is the amount of heat absorbed when one mole of liquid is changed into vapours at its boiling point. The pressure during the change is kept one atmosphere.

17. Molar Heat of Sublimation (ΔH_s)

It is the amount of heat absorbed when one mole of a solid sublimates to give one mole of vapours at a particular temperature and one atmospheric pressure.

18. Dynamic Equilibrium

Dynamic equilibrium is a situation when two opposing changes occur at equal rates. For example,

**19. Liquid Crystals**

Liquid crystalline state exists between two temperatures i.e. melting temperature and clearing temperature.

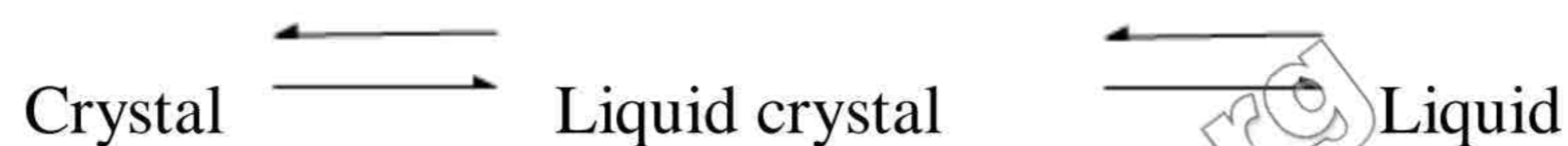
**20. Non-polar molecule**

A molecule in which there is no polarity. This is due to the absence of electronegativity difference between two bonded atoms. H_2 , O_2 , N_2 , Cl_2 etc are perfectly non-polar molecules.

21. Polar molecule

The molecule which has partial positive and partial negative charge on it due to the difference of electronegativity between the two bonded atoms is called polar molecule. For example, HCl is a polar molecule.

SOLIDS**1. Solids**

Solids are those substances which are rigid, hard, have definite shape and definite volume.

2. Crystalline Solids

Those solids in which atoms, ions or molecules are arranged in a definite three-dimensional pattern are called crystalline solids. Example, ionic solids, covalent solids, molecular solids, metallic solids.

3. Amorphous Solids

Those solids whose constituent atoms, ions or molecules do not possess a regular orderly arrangement. Example, glass, plastics, rubber, glue etc.

4. Crystallites

The regions of orderly arrangement in otherwise amorphous solids i.e. crystalline parts are called crystallites.

5. Cleavage plane

That plane along which a crystal undergoes cleavage is called cleavage plane. All the crystalline substances have cleavage planes.

6. Cleavage

It is a breaking of a crystal along definite planes.

7. Anisotropy

Some of the crystals show variation in physical properties depending upon the direction. Such properties are called anisotropic properties and the phenomenon is referred to as anisotropy. Example, graphite conducts electricity only parallel to the layers.

8. Symmetry

The repetition of faces, angles or edges when a crystal is rotated by 360° along its axis is called symmetry. Example, plane of symmetry, axis of symmetry, center of symmetry.

9. Habit of a Crystal

The shape of a crystal in which it usually grows is called habit of a crystal. Example, NaCl becomes needle like in the presence of 10% urea in solution.

10. Isomorphism

It is the phenomenon in which two different substances exist in the same crystalline form. Example, NaNO_3 and KNO_3 are rhombohedral as atomic ratio is 1:1:3.

11. Polymorphism

It is a phenomenon in which a single compound exists in more than one crystalline form. The compound is called a polymorphic and forms are called polymorphs. Example, AgNO_3 exists in rhombohedral and orthorhombic.

12. Allotropy

The existence of an element in more than one crystalline form is known as allotropy and these forms are called allotropes or allotropic forms. Example, sulphur is rhombic as well as monoclinic

13. Transition Temperature

It is that temperature in which two crystalline forms of the same substance can co-exist in equilibrium with each other. At this temperature, one crystalline form of a substance changes to another.

Grey tin (cubic) $\xrightleftharpoons{13.2^\circ\text{C}}$ White tin (Tetragonal)

14. Crystal lattice

A crystal lattice is an array of points representing atoms, ions or molecules of a crystal arranged at different sites in three-dimensional space.

15. Unit cell

The smallest part of the crystal lattice which has all the characteristic features of the entire crystal is called a unit cell.

16. Crystallographic elements/cell dimensions

The three sides of the crystal a , b , c and the three angles α , β and γ are called crystallographic elements or cell dimensions.

17. Crystal System

A crystal system may be identified by the cell dimensions of its unit cell along its three edges or axes a , b , c and three angles between the axes α , β and γ .

18. Ionic Solids

Those crystalline solids in which positively and negatively charged ions are held together through ionic bond are called ionic solids. NaCl, KBr, CsF etc are examples.

19. Lattice Energy

Lattice energy is the energy released when one mole of the ionic crystal is formed from the gaseous ions. It is also defined as the energy required to break one mole of solid into isolated ions in the gas phase. It is represented by KJ/mol.



20. Covalent Solids

Those crystalline solids in which the atoms of similar elements or different elements are held together through covalent bonds are called covalent solids. Example, diamond

21. Metallic Solids

Those crystalline solids in which the metal atoms are held together by metallic bonds are called metallic solids. For example, Fe, Co, Ni, Au etc.

22. Metallic bond

The force of attraction which binds the positive metal ions due to the presence of free electrons is called metallic bond. This is due to free electrons in the metallic lattice.

23. Cubic close packing

The arrangement of the metal atoms in which the atoms of the fourth layer are just above the first layer and the coordination number of any one of the metal atoms is twelve. They are ABC or 123 type crystals.

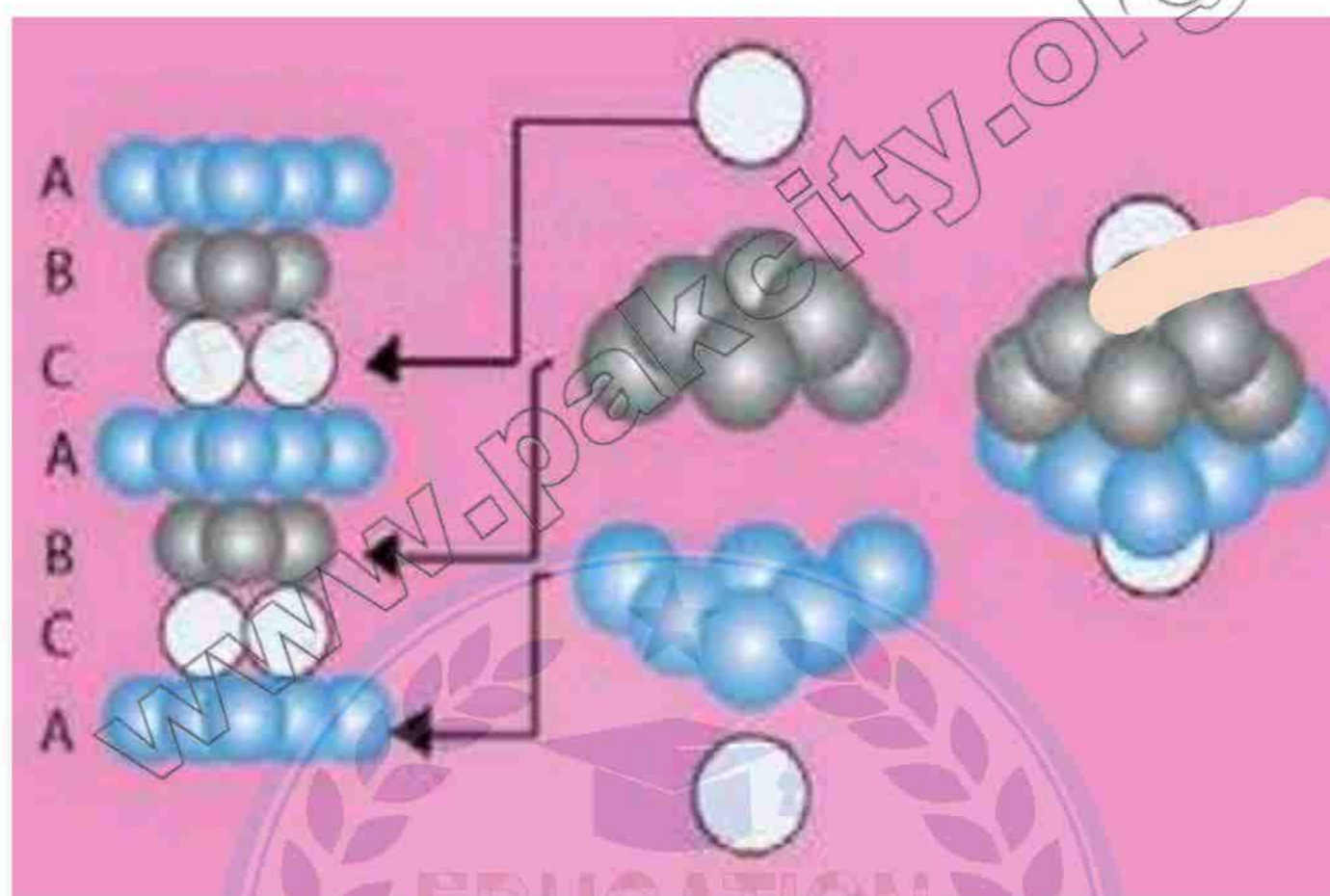

24. Hexagonal close packing

The arrangement of the metal atoms in which the atoms of the third layer are just above the atoms of the first layer and the coordination number of any one of the metal atoms is twelve. They are ABAB or 1212 type crystals.

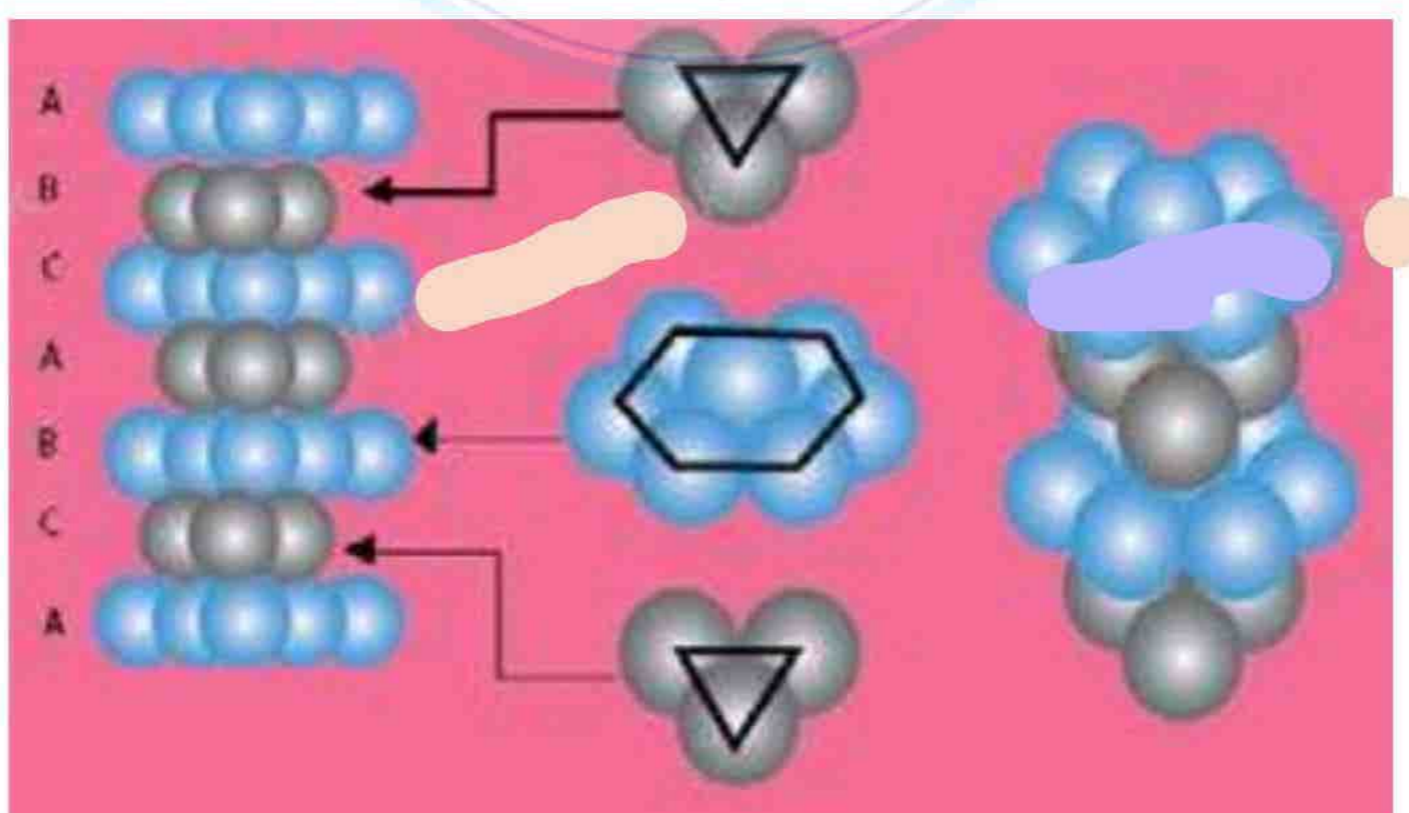

CHAPTER 5

Atomic Structure

DEFINITIONS

Give definitions of the following terms:

1. Cathode Rays

It is a stream of negatively charged particles which are called electrons. These are produced at very high voltage and very low pressure in the discharge tube. They travel from cathode to anode and are produced by any substance in the vapourized/gaseous form.

2. Anode Rays

It is a stream of positively charged particles which are produced in the discharge tube at high voltage and low pressure. They are also referred to as canal rays or positive rays. They pass through holes or canals in the cathode.

3. Frequency

Frequency is the number of waves passing through a point per second. It is denoted by ν

$$\nu = c/\lambda$$

4. Wavelength

Wavelength is the distance between two adjacent crests or troughs and expressed in \AA , nm or pm ($1\text{\AA}=10^{-10}$ m, $1\text{ nm}=10^{-9}$ m, $1\text{ pm}=10^{-12}$ m).

5. Wave number

Wave number is the number of waves per unit length and is reciprocal to wavelength. It is denoted by $\bar{\nu}$.

$$\bar{\nu} = 1/\lambda$$

6. Spectrum

A visual display or dispersion of the components of white light when it is passed through a prism is called a spectrum.

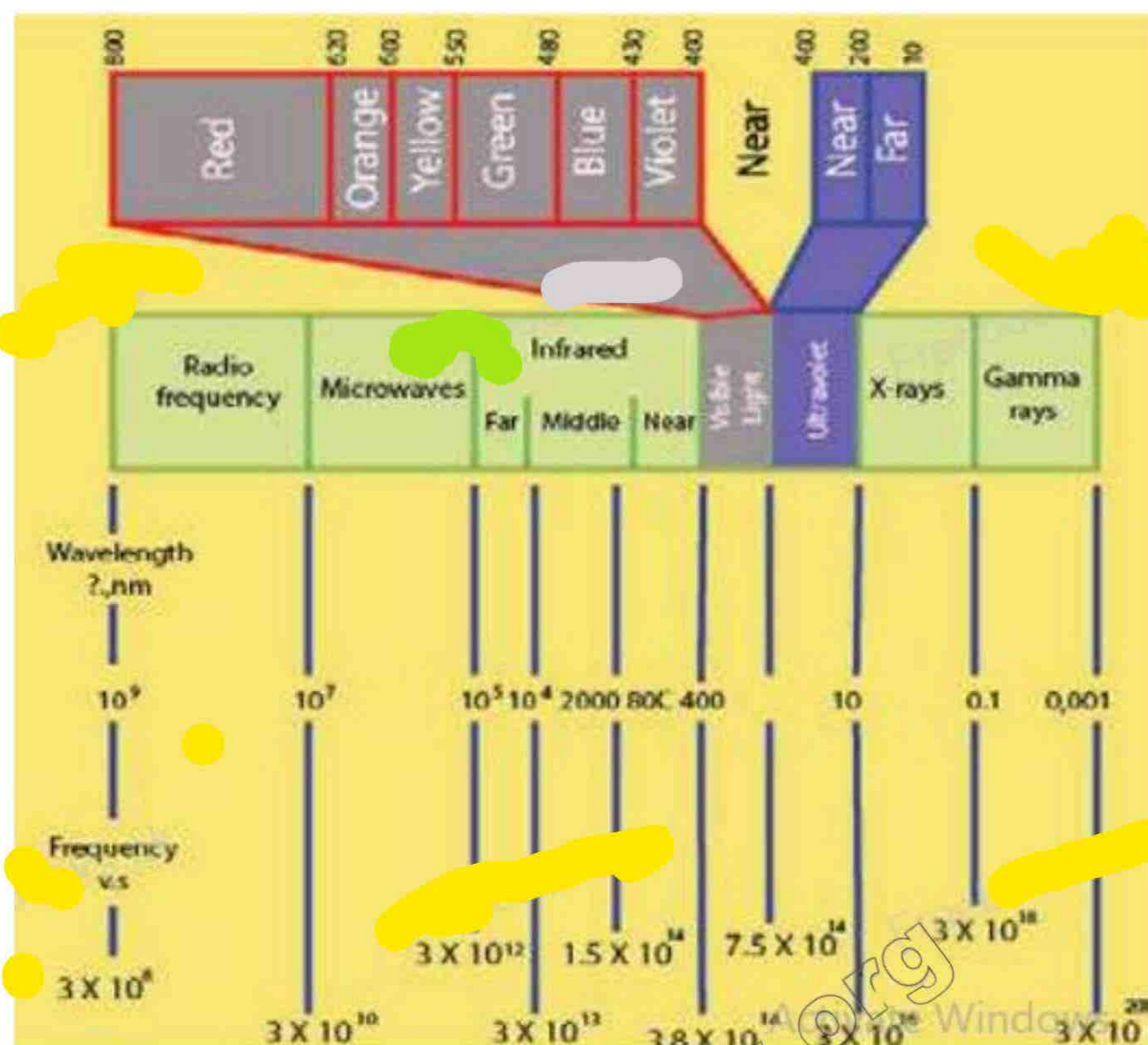

7. Continuous spectrum

In continuous spectrum, the boundary line between the colours cannot be marked. The colours diffuse into each other. One colour merges into another without any dark space. The best example of continuous spectrum is rainbow. It is obtained from the light emitted by the sun or incandescent (electric light) solids. It is the characteristic of matter in bulk.

8. Atomic or Line spectrum

When an element or its compound is volatilized on a flame and the light emitted is seen through a spectrometer we see distinct lines separated by dark spaces. This is characteristic of an atom. The number of lines and the distance between them depend upon the element volatilized. For example, line spectrum of sodium contains two yellow lines separated by a definite distance. For hydrogen there are many lines with different colours and distances.

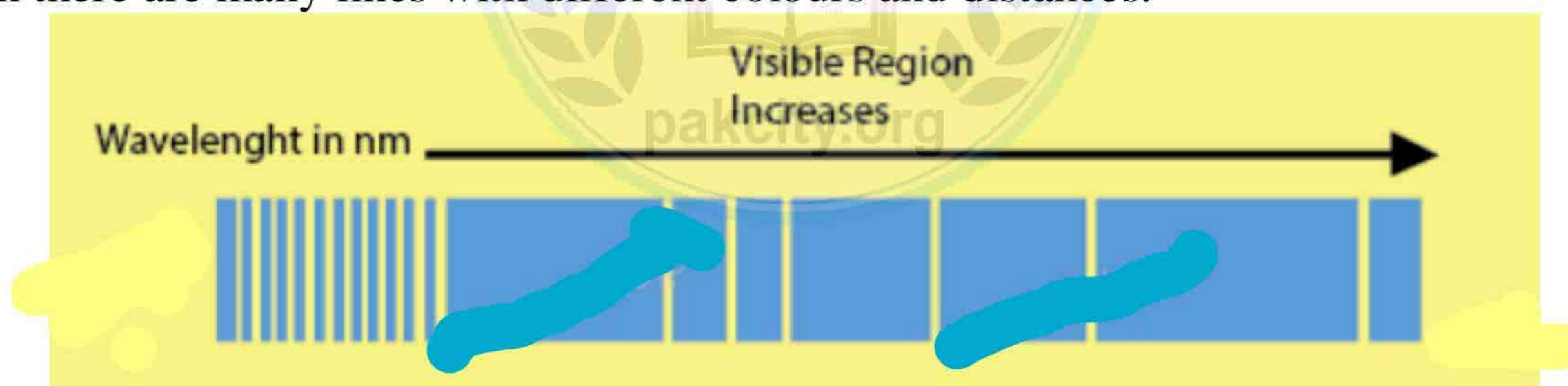

Atomic spectrum of hydrogen

9. Atomic emission spectrum

When solids are volatilized or elements in their gaseous states are heated to high temperature or subjected to an electrical discharge radiation of certain wavelengths are emitted. The spectrum of this radiation contained bright lines against a dark background.

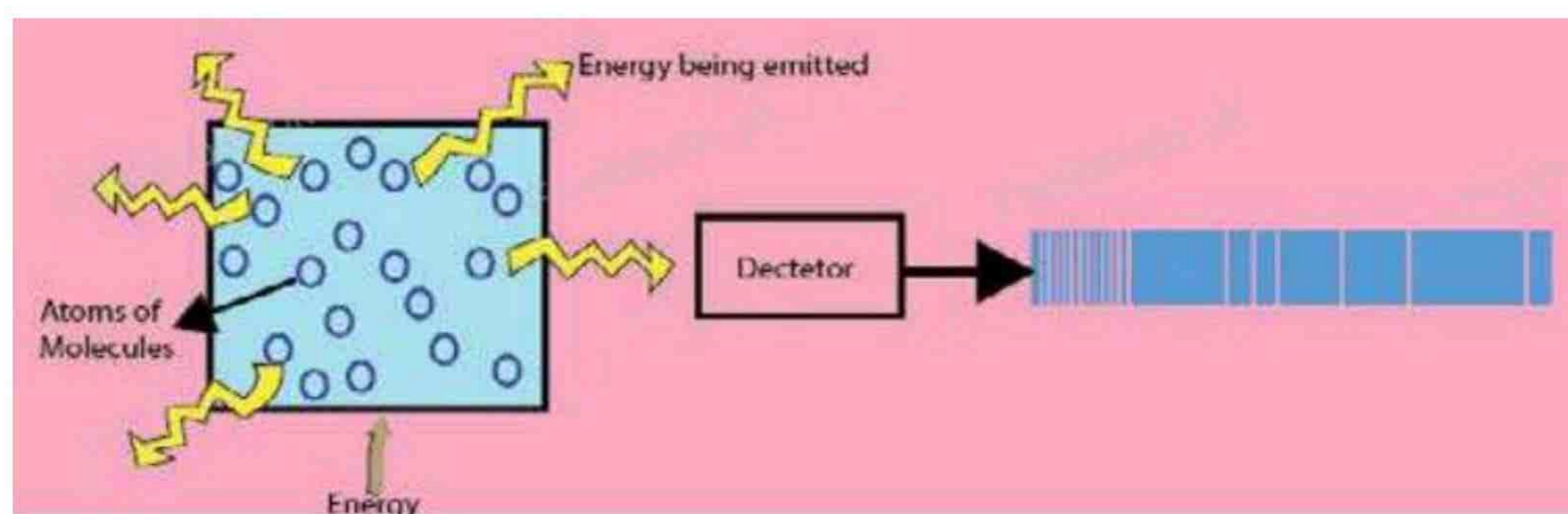

10. Atomic absorption spectrum

When a beam of white light is passed through a gaseous sample of an element, the element absorbs certain wavelengths while the rest of wavelengths pass through it. The wavelengths of the radiation that have been absorbed by the element appear as dark lines and the background is bright.

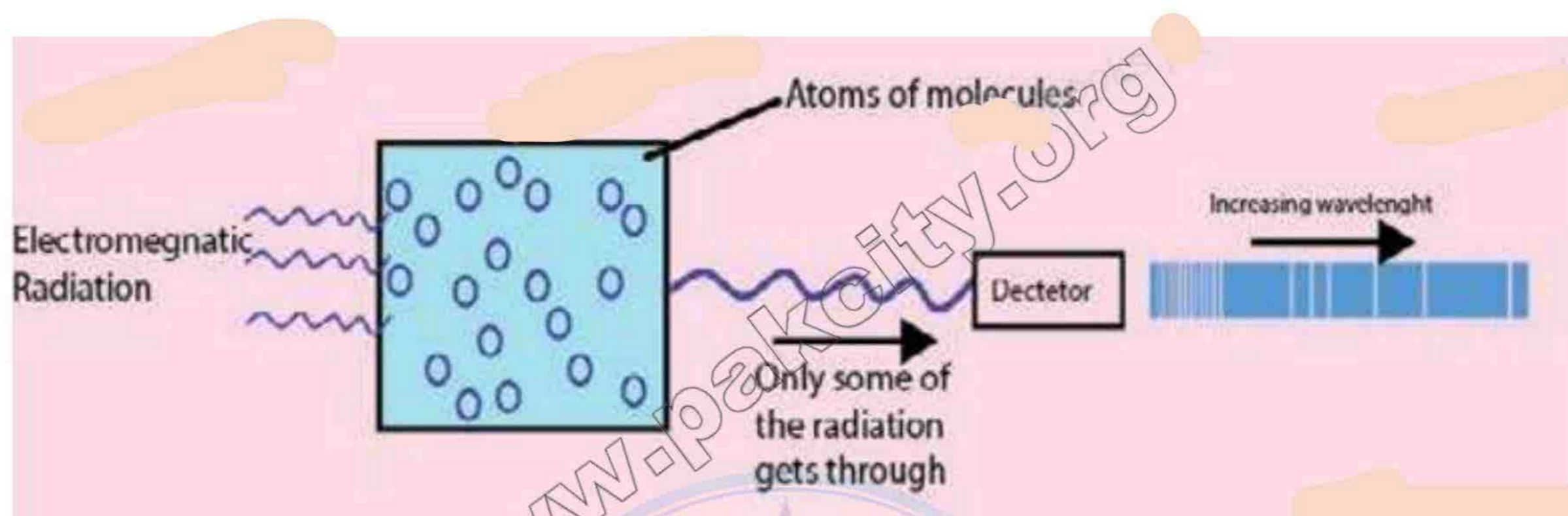

11. X-Rays

X-rays are produced when rapidly moving electrons collide with heavy metal anode in the discharge tube.

12. Moseley Law

The frequency of a spectral line in X-ray spectrum varies as the square of atomic number of an element emitting it.

$$\sqrt{\nu} = a(Z-b)$$

13. Heisenberg's uncertainty principle

It is difficult to determine the position as well as the momentum of the electron simultaneously.

14. Orbital

The volume of space in which there is 95% chance of finding an electron is called atomic orbital.

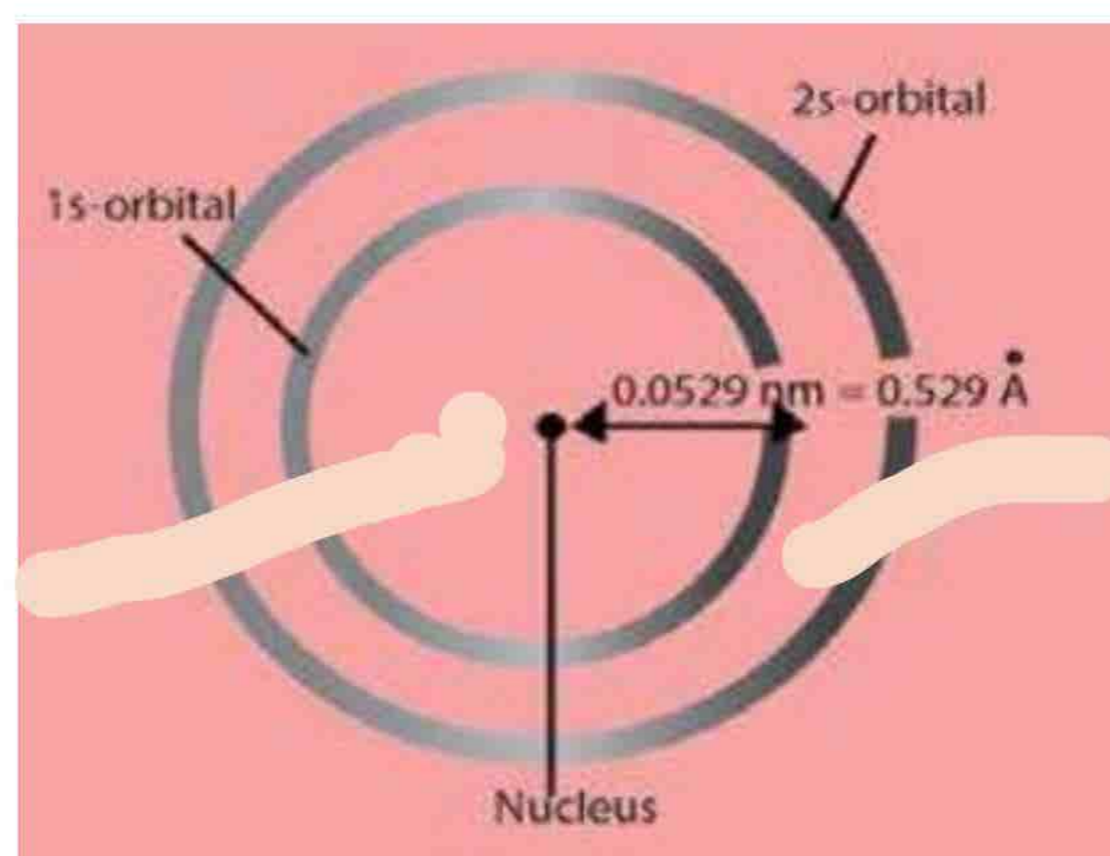

15. Quantum numbers

Quantum numbers serve as identification numbers which completely describe an electron. There are four quantum numbers i.e. principal quantum number (n), azimuthal quantum number (l), magnetic quantum number (m) and spin quantum number (s).

16. ($n+l$) rule

Subshells are arranged in the increasing order of ($n+l$) values and if any two sub-shells have the same ($n+l$) values then that sub-shell is placed first whose n value is smaller.

17. Aufbau Principle

The electrons should be filled in energy subshells in order of increasing energy values. The electrons are first placed in $1s$, $2s$, $2p$ and so on.

18. Pauli's Exclusion Principle

It is impossible for two electrons residing in the same orbital of a poly-electron atom to have the same values of four quantum numbers.

Or



Two electrons in the same orbital should have opposite spins

19. Hund's Rule

If degenerate orbitals are available and more than one electrons are to be placed in them they should be placed in separate orbitals with the same spin rather than putting them in the same orbital with opposite spins.

E.g

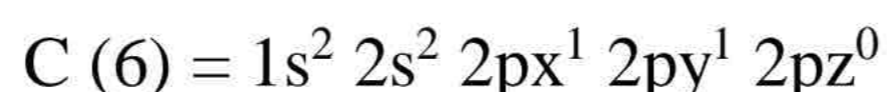

CHAPTER 6

Chemical Bonding

DEFINITIONS

Give definitions of the following terms:

1. Octet Rule

The tendency of an element to gain eight electrons in the outermost shell by gaining, losing or sharing electrons is called octet rule.

For Example: $\text{Na} \rightarrow \text{Na}^+ + e^-$ (Na^+ has 8 e in outermost shell)

2. Atomic Radius

The atomic radius means the average distance between the nucleus of the atom and the outermost electronic shell.

For Example: The radius of H is $0.529 \times 10^{-10} \text{m}$ (0.0529nm)

3. Ionic Radius

The ionic radius of an ion is the radius of the ion while considering it to be spherical in shape. For example, the ionic radius of K^+ is 133 pm and Cl^- is 181 pm.

4. Covalent Radius

The covalent radius of an element is defined as half of the single bond length between two similar atoms covalently bonded in a molecule. For example, covalent radius of carbon is 77.3 pm in CH_3Cl .

5. Ionization Energy

The ionization energy of an element is the minimum energy required to remove an electron from its gaseous atom to form an ion. For example,

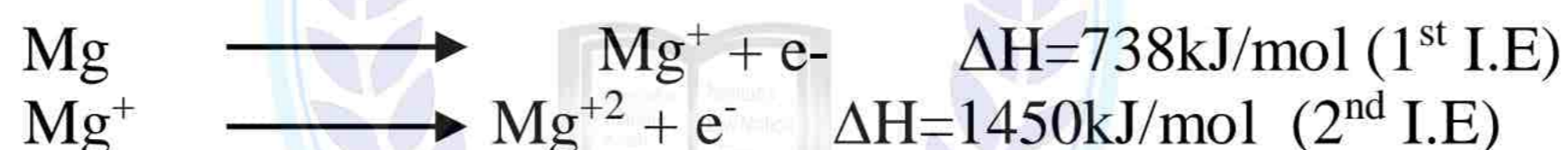

6. Electron Affinity

The electron affinity of an atom is the energy released when an electron adds to an empty or partially filled orbital of an isolated gaseous atom in its valence energy level to form an anion having a unit negative charge. For example,



7. Electronegativity

The tendency of an atom to attract a shared electron pair towards itself is called its electronegativity. For example, fluorine is the most electronegative element with E.N value 4.

8. Ionic Bond

According to the Lewis theory, ionic bond is formed by the complete transfer of electrons from an atom with low ionization energy to another atom with high electron affinity. For example, the bond in NaCl is ionic.

9. Covalent Bond (electron pair bond)

According to Lewis and Kossel, a covalent bond is formed by the mutual sharing of electrons between two atoms. For example, the bond in H₂ molecule and Cl₂ molecule.



10. Coordinate Covalent Bond

A coordinate covalent bond is formed between two atoms when the shared pair of electrons is donated by one of the bonded atoms. For example, the bond between BF₃ and NH₃.

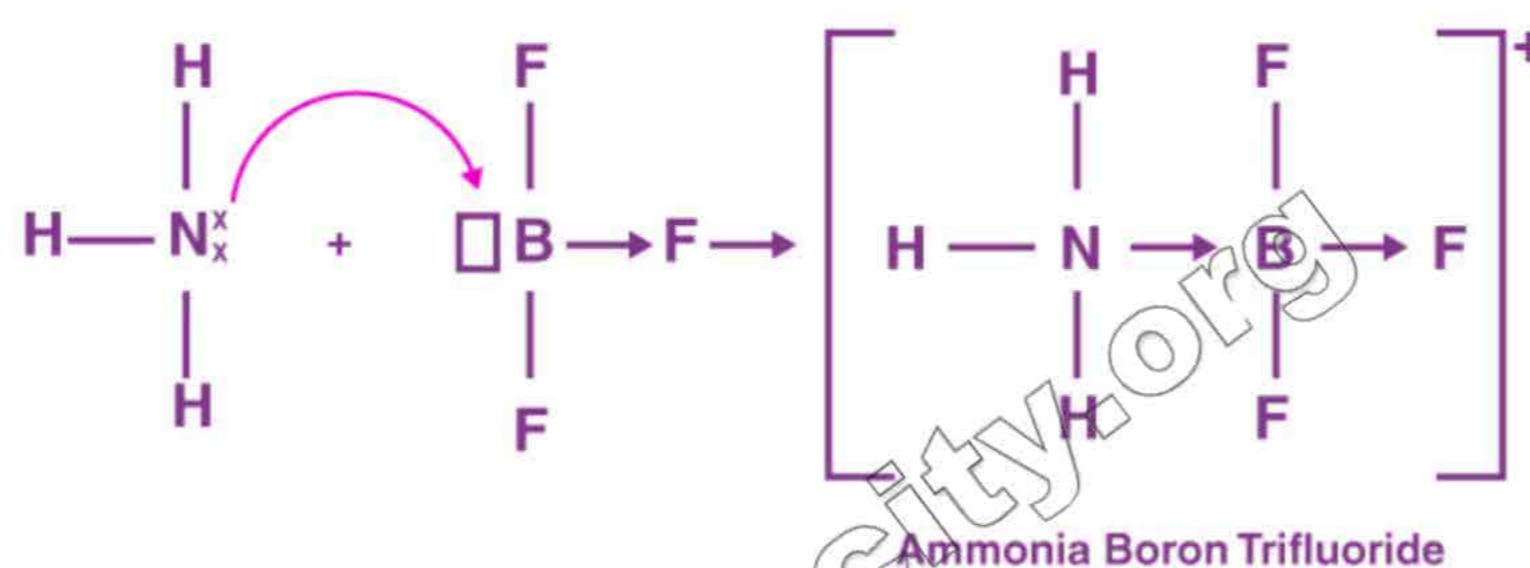

11. Sigma Bond

The bond formed due to head on approach to two atomic orbitals and in which the electron density lies in between the line joining nuclei is called a sigma bond.

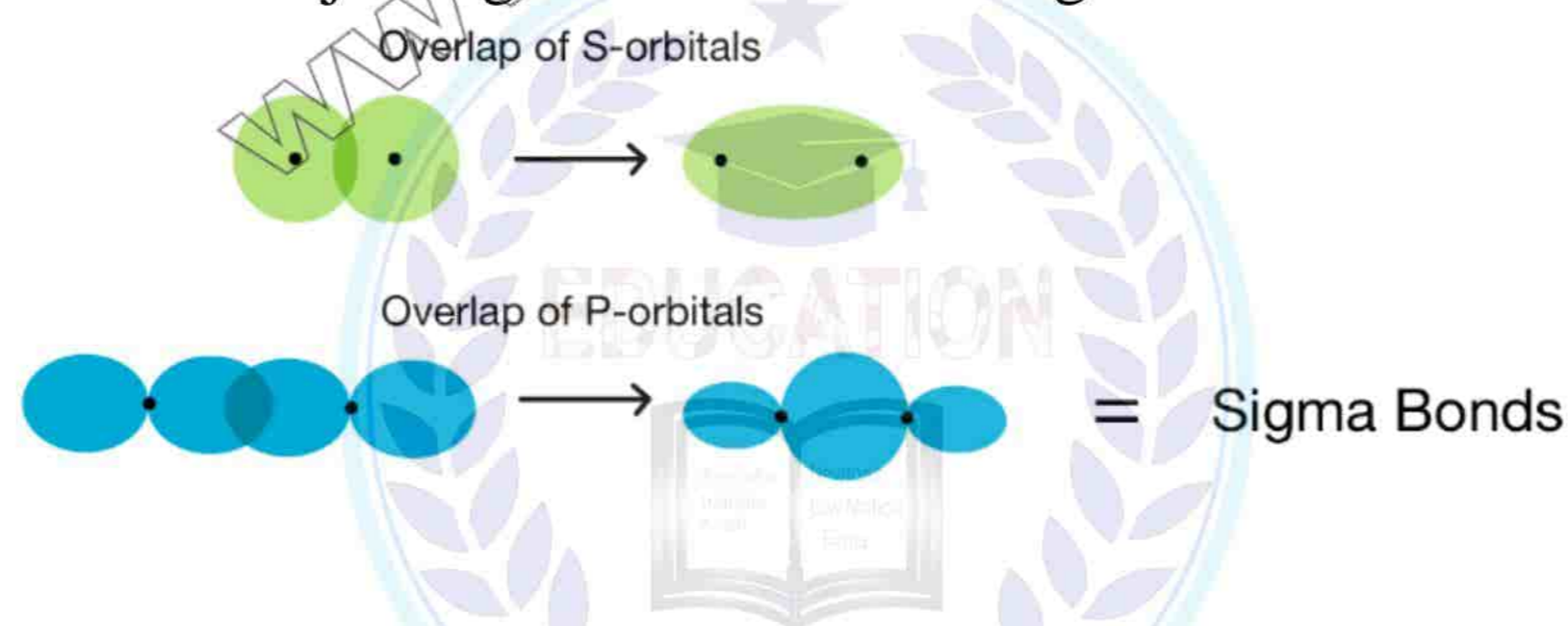

12. pi Bond

The bond formed due to parallel approach of two atomic orbitals and in which the electron density lies above and below the line joining nuclei.

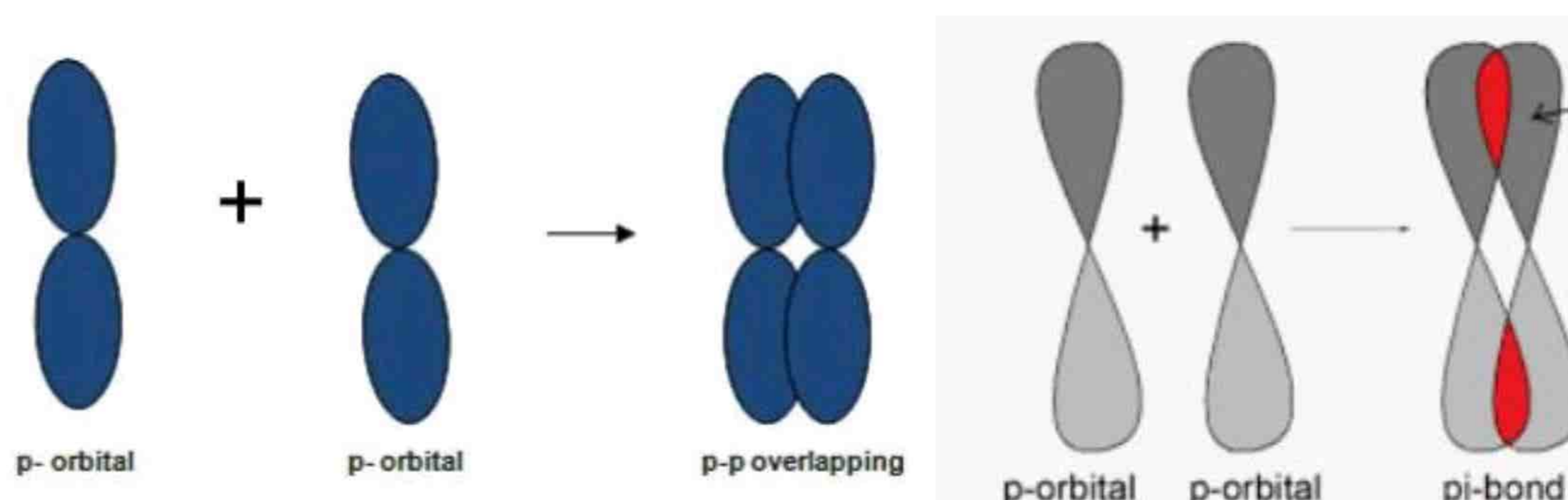

13. Hybridization

Hybridization is a concept in which atomic orbitals of different energy and shape intermix to form a new set of orbitals of same shape and energy.

14. sp^3 hybridization

When one 's' and three 'p' atomic orbitals intermix to form a set of four equivalent sp^3 hybrid orbitals then it is called sp^3 hybridization.

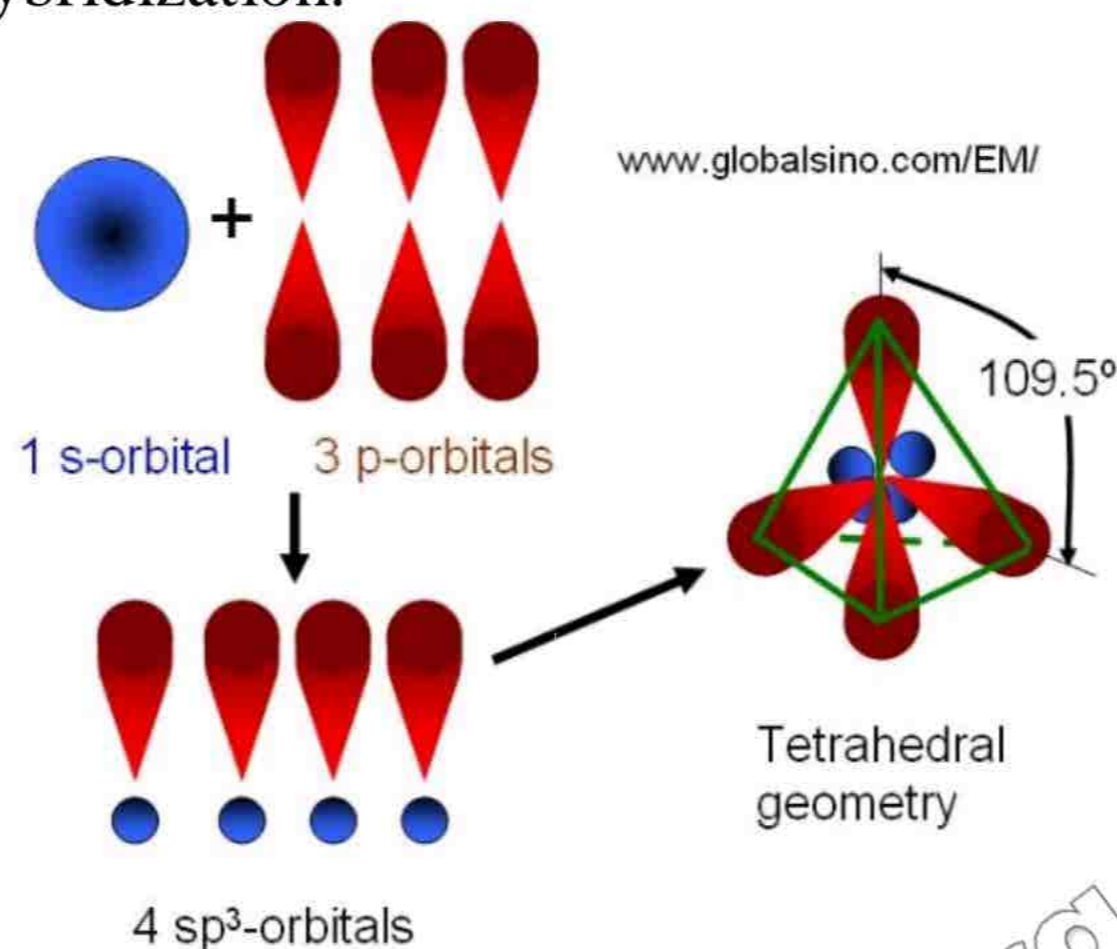

15. sp^2 hybridization

When one 's' and two 'p' atomic orbitals intermix to form a set of three equivalent sp^2 hybrid orbitals then it is called sp^2 hybridization.

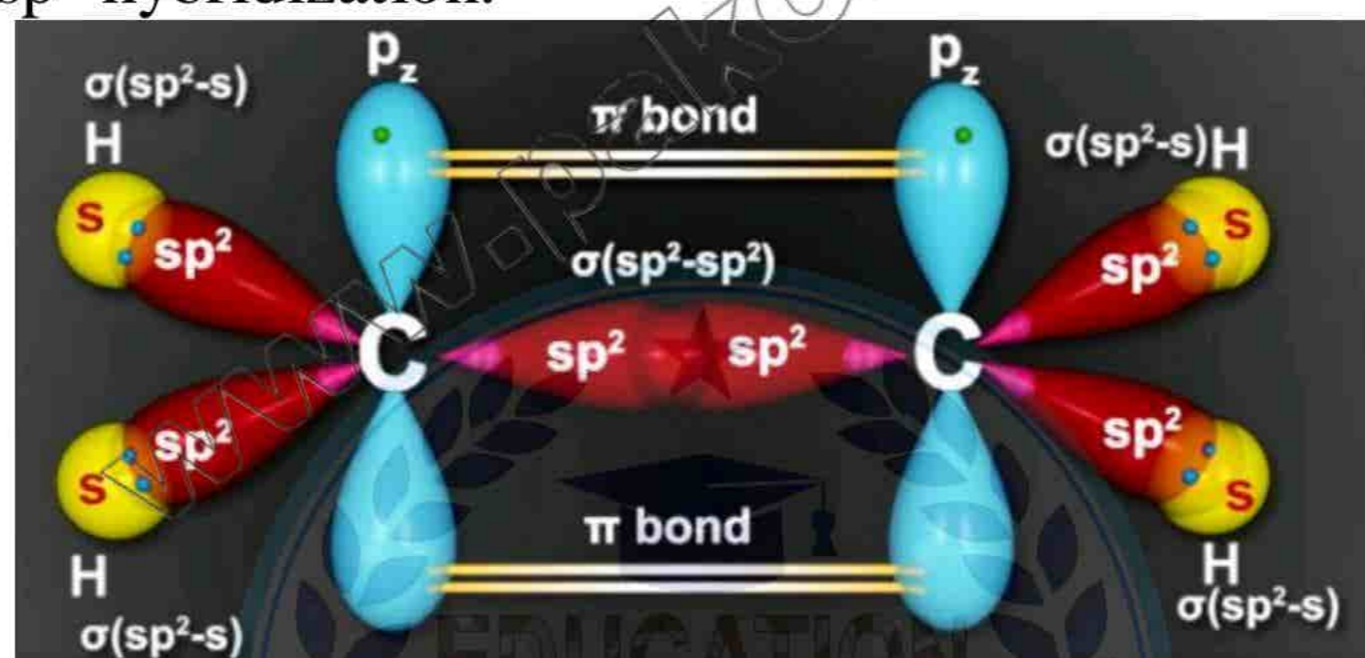

16. sp hybridization

When one 's' and one 'p' atomic orbitals intermix they form a set of two equivalent sp hybrid orbitals then it is called sp hybridization.

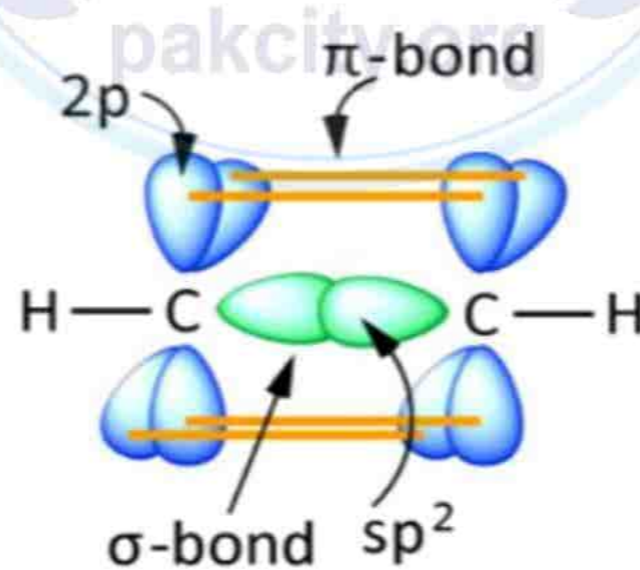

17. Bond Energy

The bond energy is the average amount of energy required to break all bonds of a particular type in one mole of the substance. For example, bond energy of hydrogen molecule is 436 kJ/mol.

18. Bond Length

The distance between the nuclei of two atoms forming a covalent bond is called the bond length. For example, in most of the aliphatic hydrocarbons the C-C bond length is 154 pm.

19. Dipole Moment

The dipole moment is defined as the product of the electric charge (q) and the distance between the positive and negative charges (r). Its unit is Debye (D). The dipole moment of water is 1.85 D.

$$\mu = q \times r$$



CHAPTER 7

Thermochemistry

DEFINITIONS

Give definitions of the following terms:

1. Thermochemistry

The study of heat changes accompanying a chemical reaction is known as thermochemistry.

2. Exothermic Reaction

When an exothermic reaction occurs heat is given out by the system and the temperature of the system rises above the room temperature. Eventually the temperature of the system falls to room temperature again as the heat produced is lost to the surroundings. ΔH is negative.



3. Endothermic Reaction

When an endothermic reaction occurs the heat required for the reaction is taken from the reacting materials (system) and the temperature of the system falls below the initial temperature. Eventually the temperature of the system rises to room temperature again as heat is absorbed from the surroundings. ΔH is positive.



4. Spontaneous reactions

A process which takes place on its own without any outside assistance and moves from a non-equilibrium state towards an equilibrium state. For example, burning of wood and candle.

5. Non-spontaneous reactions

A process which does not happen on its own and some external agency is required to carry out reactions. The decomposition of H_2O to give H_2 and O_2 requires electrical current.

6. System

Anything (materials) under test in the laboratory or under consideration in the classroom for the purpose of argument. E.g. zinc and copper sulphate solution.

7. Surrounding

The environment around the system is surrounding. E.g. table, air etc.

8. Boundary

A real or imaginary surface which separates the system from the surroundings. E.g. wall of flask containing solution.

9. State

The condition of a system is called state. Initial condition is called initial state and final condition is called final state. E.g V_1, V_2, T_1, T_2 etc.

10. State Function

A macroscopic property of a system which has definite values for initial and final states and which is independent of the path adopted to bring about a change. E.g. P, T, V, E, H.

11. Heat

Quantity of energy that flows across the boundary of a system during a change in its state due to the difference in temperature between the system and surroundings.

12. First Law of Thermodynamics

The first law of thermodynamics is also called the law of conservation of energy. It states that energy can neither be created nor destroyed but can be changed from one form to another.

13. Enthalpy

It is the total heat content of the system and is denoted by H. The change of enthalpy is measured at constant pressure. The change of enthalpy is denoted by ΔH .

14. Enthalpy of a Reaction (ΔH°)

The standard enthalpy of reaction ΔH° is the enthalpy change which occurs when the certain number of moles of reactants as indicated by the balanced chemical equation react together completely to give the products under standard condition, i.e. 25°C (298 K) and one atmospheric pressure.



15. Enthalpy of Formation (ΔH°_f)

The standard enthalpy of formation of a compound is the amount of heat absorbed or evolved when one mole of the compound is formed from its elements.



16. Enthalpy of Atomization ($\Delta H^\circ_{\text{at}}$)

The standard enthalpy of atomization of an element is defined as the amount of heat absorbed when one mole of gaseous atoms is formed from the element under standard conditions.



17. Enthalpy of Neutralization (ΔH°_n)

The standard enthalpy of neutralization is the amount of heat evolved when one mole of hydrogen ions from an acid react with one mole of hydroxide ions from a base to form one mole of water.

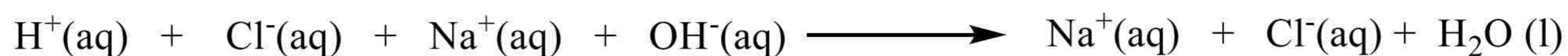

18. Enthalpy of Combustion ($\Delta H^{\circ}_{\text{c}}$)

The standard enthalpy of combustion of a substance is the amount of heat evolved when one mole of a substance is completely burnt in excess of oxygen under standard conditions.



19. Enthalpy of Solution ($\Delta H^{\circ}_{\text{sol}}$)

The standard enthalpy of solution is the amount of heat absorbed or evolved when one mole of a substance is dissolved in so much solvent that further dilution results in no detectable heat change. For example, enthalpy of solution of ammonium chloride is +16.2 KJ/mol and that of sodium carbonate is -25 KJ/mol.

20. Hess's Law of Constant Heat Summation

If a chemical change takes place by several different routes, the overall energy change is the same regardless of the route by which the chemical change occurs provided the initial and final conditions are the same.

$$\Delta H = \Delta H_1 + \Delta H_2$$

$$\sum \Delta H(\text{cycle}) = 0$$

21. Born-Haber Cycle

It states that the energy change in a cyclic process is always zero. It calculates lattice energy of binary ionic compounds M^+X^-

22. Lattice energy

The lattice energy of an ionic crystal is the enthalpy of formation of one mole of the ionic compound from gaseous ions under standard conditions.



CHAPTER 8

Chemical Equilibrium

DEFINITIONS

Give definitions of the following terms:

1. Reversible Reactions

The reactions in which reactants combine to make products and products combine to make reactants are called reversible reactions. These reactions attain dynamic equilibrium. For example,

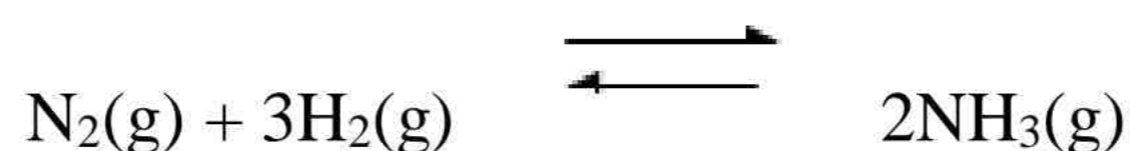

2. Irreversible Reactions

The reactions which take place in only in one direction are called irreversible reaction. These reactions attain static equilibrium. For example,



3. State of Chemical Equilibrium

When the rate of forward reaction becomes equal to the rate of reverse reaction then it is called a state of chemical equilibrium.

4. Law of Mass Action

The rate at which the reaction proceeds is directly proportional to the product of the active masses of the reactants.

$$K_c = \frac{[\text{products}]}{[\text{reactants}]}$$
 or

$$K_c = \frac{\text{rate constant for forward step}}{\text{rate constant for reverse step}}$$

5. Le-Chatelier's Principle

If a stress is applied to a system at equilibrium the system acts in such a way so as to nullify as far as possible the effect of that stress.

6. pH

pH is the negative log of the hydrogen ion concentration.

$$\text{pH} = -\log[\text{H}^+]$$

7. pOH

pOH is the negative log of the hydroxyl ion concentration.

$$\text{pOH} = -\log[\text{OH}^-]$$

8. Common Ion Effect

The addition of a common ion to the solution of a less soluble electrolyte suppresses its ionization and the concentration of unionized species increases which may come out as precipitate.

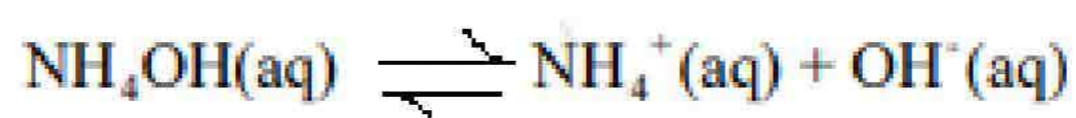

9. Buffer

Buffer is a solution which can resist change in pH when a small amount of acid or base is added. Example, mixture of acetic acid and sodium acetate and mixture of ammonium chloride and ammonium hydroxide.

10. Acidic Buffer

Acidic buffer is prepared by mixing a weak acid and salt of it with a strong base. Its pH is less than 7. For example, acetic acid and sodium acetate.

11. Basic Buffer

Basic buffer is prepared by mixing a weak base and salt of it with a strong acid. Its pH is more than 7. For example, ammonium chloride and ammonium hydroxide.

12. Buffer Capacity

The capability or capacity of a buffer to resist change in pH when a small amount of acid or base is added to it is called buffer capacity.

13. Henderson Equation

Henderson equation helps in making acidic and basic buffer of any required pH or pOH, respectively. It is expressed as:

$$\text{pH} = \text{pK}_a + \log \frac{[\text{salt}]}{[\text{acid}]}$$

$$\text{pOH} = \text{pK}_b + \log \frac{[\text{salt}]}{[\text{base}]}$$

14. Solubility Product (K_{sp})

The solubility product is the product of the concentration of ions raised to an exponent equal to the coefficient of the balanced equation.

$$K_c = \frac{[\text{Pb}^{2+}][\text{SO}_4^{2-}]}{[\text{PbSO}_4]}$$

$$K_c[\text{PbSO}_4] = [\text{Pb}^{2+}][\text{SO}_4^{2-}]$$

$$K_c[\text{PbSO}_4] = K_{sp}$$

$$K_{sp} = [\text{Pb}^{2+}(\text{aq})][\text{SO}_4^{2-}(\text{aq})] = 1.6 \times 10^{-8} \text{ at } 25^\circ\text{C}$$



CHAPTER 9

Solutions

DEFINITIONS

Give definitions of the following terms:

1. Phase

Every sample of matter with uniform properties and a fixed composition is called a phase. For example, water at room temperature and normal pressure exists as a single liquid phase.

2. Solution

A solution is a homogeneous mixture of two or more kinds of different molecular or ionic substances. For example, sugar in water.

3. Percentage weight/weight

It is the weight of a solute dissolved per 100 parts by weight of solution. 5% w/w sugar solution will contain 5 g of sugar dissolved in 100 g of solution in water.

4. Percentage volume/weight

It is the number of cm³ of a solute dissolved per 100 g of the solution. If we dissolve 10 cm³ of alcohol in water and the total weight of the solution is 100 g then it is 10% v/w solution of alcohol in water.

5. Percentage volume/volume

It is the volume of a solute dissolved per 100 cm³ of the solution. A 12% alcohol beverage is 12 cm³ of alcohol per 100 cm³ of solution.

6. Percentage weight/volume

It is the weight of a solute dissolved per 100 parts by volume of solution. 10 g of glucose dissolved in 100 cm³ of solution is 10% w/v solution of glucose.

7. Molarity (M)

Molarity is the number of moles of solute dissolved per dm³ of the solution. For example, 180 g of glucose dissolved in 1 dm³ of water.

$$\text{Molarity (M)} = \frac{\text{Mass of solute}}{\text{Molar Mass of solute}} \times \frac{1}{\text{Volume of solution dm}^3}$$

$$\text{Molarity (M)} = \frac{\text{Number of moles of solute}}{\text{Volume of solution dm}^3}$$

8. Molality (m)

Molality is the number of moles of solute in 1000 g (1 kg) of the solvent. For example, 180 g of glucose dissolved in 1000 g of solvent.

$$\text{Molality (m)} = \frac{\text{Mass of solute}}{\text{Molar mass of solute}} \times \frac{1}{\text{Mass of solvent in kg}}$$

$$\text{Molality (m)} = \frac{\text{Number of moles of solute}}{\text{Mass of solvent in kg}}$$

9. Mole fraction (x)

The mole fraction of any component in a mixture is the ratio of the number of moles of it to the total number of moles of all the components present. For example, let A, B and C be the three components making a solution. The number of moles are n_A , n_B , n_C and mole fractions be x_A , x_B , x_C .

$$x_A = \frac{n_A}{n_A + n_B + n_C}$$

$$x_B = \frac{n_B}{n_A + n_B + n_C}$$

$$x_C = \frac{n_C}{n_A + n_B + n_C}$$

10. Parts per million (ppm)

It is defined as the number of parts (by weight or volume) of a solute per million parts (by weight or volume) of the solution.

$$\text{Parts per million (ppm)} = \frac{\text{Mass of solute}}{\text{Mass of solution}} \times 10^6$$

11. Conjugate solutions

When two partially miscible liquids are shaken together each liquid layer is a saturated solution of the other liquid layer. Such solutions are called conjugate solutions. For example, phenol-water system.

12. Critical solution temperature/upper consolute temperature

The temperature at which two conjugate solutions merge into one another is called critical solution temperature or upper consolute temperature. For example, 65.9°C is the consolute temperature of phenol-water system.

13. Completely miscible liquids

Liquids which completely mix up in each other in all proportions are called completely miscible liquids. For example, water and alcohol.

14. Partially miscible liquids

Liquids which dissolve into one another to a limited extent are called partially miscible liquids. For example, ether dissolves water to the extent of 1.2% and water dissolves ether up to 6.5%.

15. Liquids practically immiscible

Those liquids which do not dissolve into each other in any proportion are immiscible. For example, water and benzene.

16. Raoult's Law

The vapour pressure of a solvent above a solution is equal to the product of the vapour pressure of pure solvent and the mole fraction of solvent in solution.

$$p = p^0 x_1$$

The lowering of vapour pressure is directly proportional to the mole fraction of solute. The relative lowering of vapour pressure is equal to the mole fraction of solute.

17. Zeotropic mixtures

Such liquid mixtures which distill with a change in composition are called zeotropic mixtures. For example, methyl alcohol-water solution.

18. Azeotropic mixtures

Azeotropic mixtures are those which boil at constant temperature and distil over without change in composition at any temperature like a pure chemical compound. For example, water ethanol, water hydrochloric acid mixture.

19. Solubility

Solubility is defined as the concentration of solute in solution when it is in equilibrium with the solid substance at a particular temperature. For example, saturated solution of NaCl in water is 37.5 g of NaCl in 100 g of water.

20. Solubility curve

A graphical representation between temperature and solubility of solution is called solubility curve. There are two types of solubility curves:

- Continuous solubility curve
- Discontinuous solubility curve

21. Continuous solubility curve

Continuous solubility curves don't have sharp breaks anywhere. For example, KClO_3 , $\text{K}_2\text{Cr}_2\text{O}_7$, $\text{Pb}(\text{NO}_3)_2$ and CaCl_2 show continuous solubility curves.

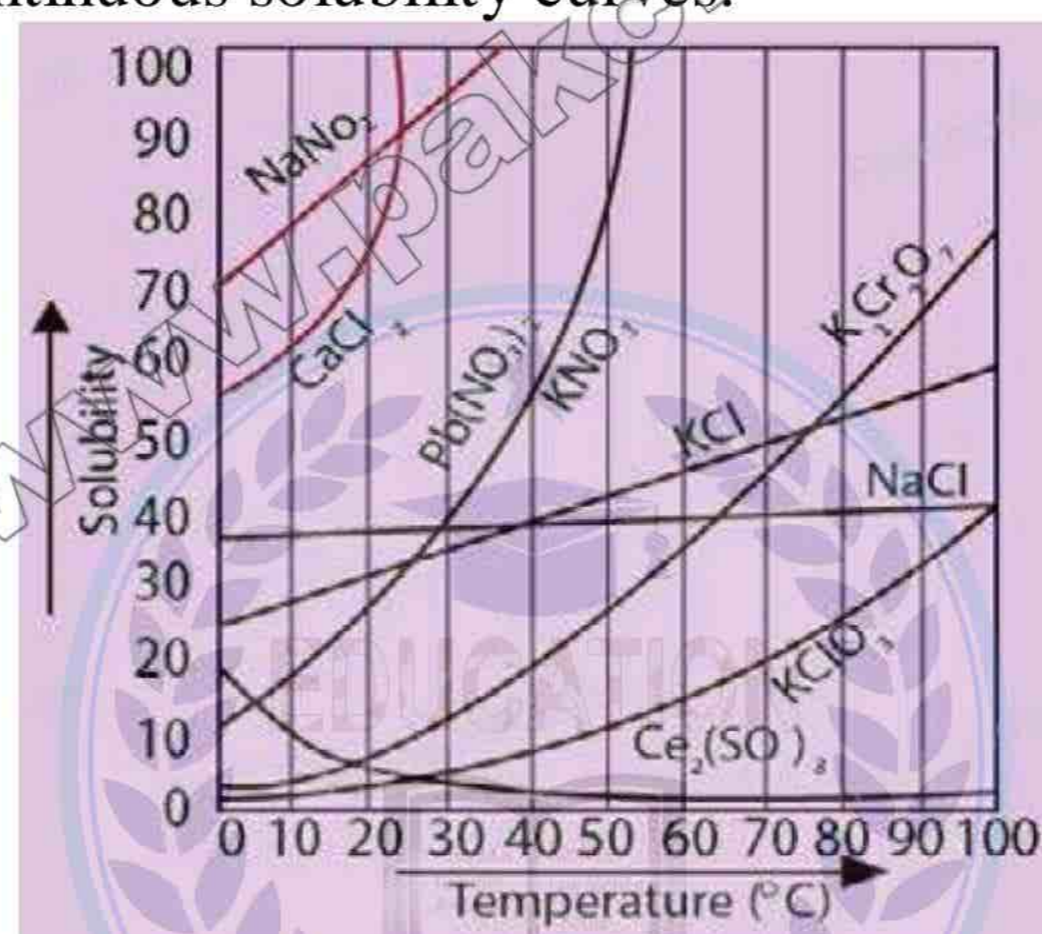

22. Discontinuous solubility curve

Sometimes, the solubility curves show sudden changes of solubilities and these curves are called discontinuous solubility curves. For example, $\text{Na}_2\text{SO}_4 \cdot 10 \text{H}_2\text{O}$, $\text{CaCl}_2 \cdot 6 \text{H}_2\text{O}$.

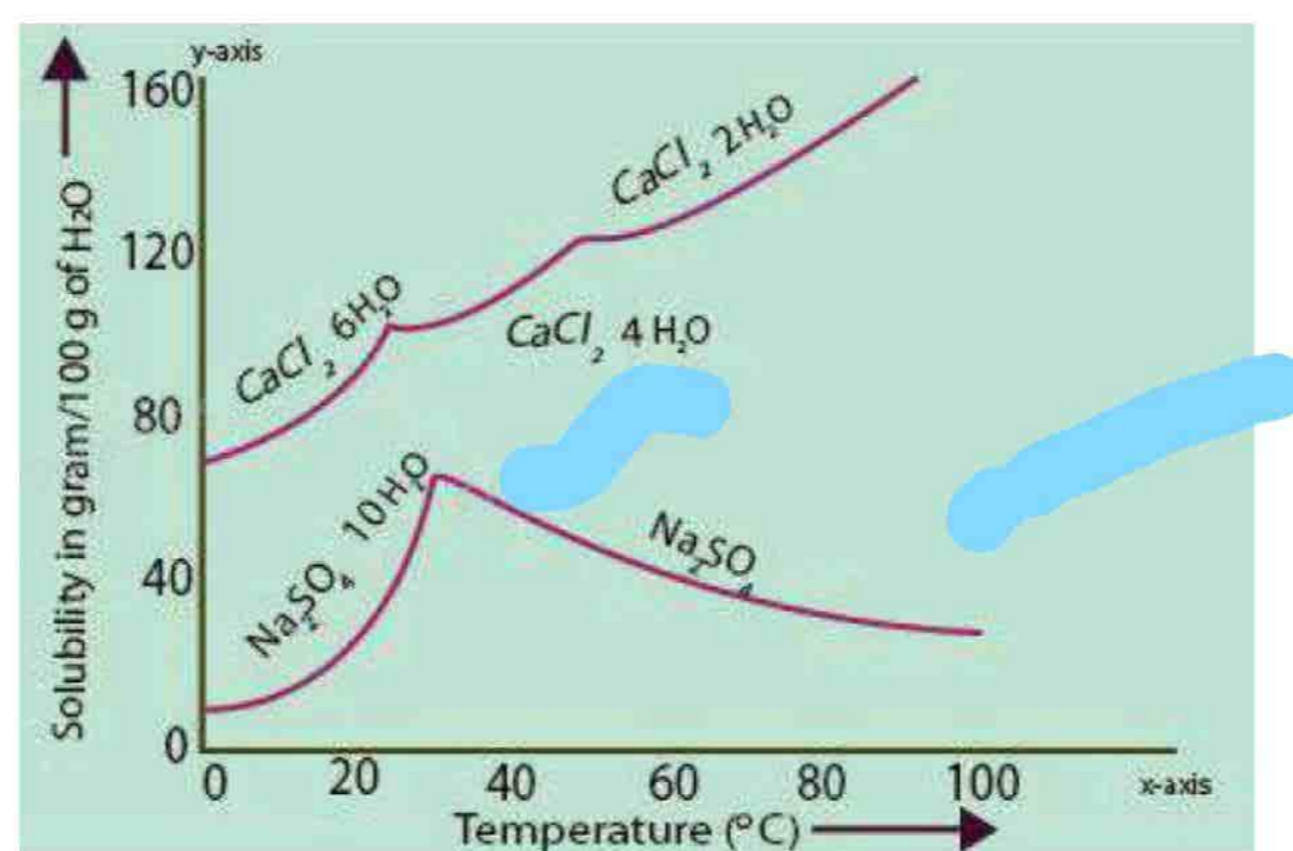

23. Colligative Properties

Colligative properties are the properties of solution that depend upon the number of solute and solvent molecules or ions. For example, lowering of vapour pressure, elevation of boiling point, depression of freezing point.

24. Heat of solution

The quantity of heat energy that is absorbed or released when a substance forms solution is termed as heat of solution. The enthalpy or heat of solution is defined as the heat change when one mole of the substance is dissolved in a specified number of moles of solvent at a given temperature. For example, enthalpy of solution ($\Delta H^{\circ}_{\text{sol}}$) of ammonium chloride is $+16.2 \text{ KJmol}^{-1}$ and that of sodium carbonate is -25 KJmol^{-1} .

25. Hydration

The process in which water molecules surround and interact with solute ions or molecules is called hydration. For example, sodium ions surrounded by water molecules.

26. Hydrate

The crystalline substances which contain chemically combined water in definite proportions is called a hydrate. For example, $\text{CuSO}_4 \cdot 5\text{H}_2\text{O}$.

27. Water of crystallization

Those water molecules which combine with substances as they are crystallized from aqueous solutions are called water molecules of crystallization or water of hydration. For example, $(\text{COOH})_2 \cdot 2\text{H}_2\text{O}$ oxalic acid.

28. Hydrolysis

The interactions between salts and water are called hydrolytic reactions and the phenomenon is known as hydrolysis.

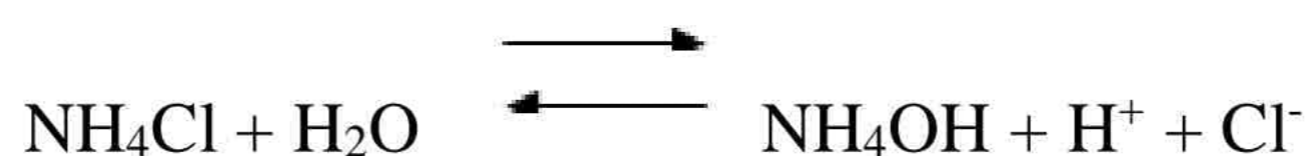

CHAPTER 10

Electrochemistry

DEFINITIONS

Give definitions of the following terms:

1. Electrochemistry

Electrochemistry is concerned with the conversion of electrical energy into chemical energy in electrolytic cells as well as the conversion of chemical energy into electrical energy in galvanic or voltaic cells.

2. Oxidation number or state

It is the apparent charge on an atom of an element in a molecule or an ion. It may be positive or negative or zero. Example, Na^{+1} , F^{-1} , CO_3^{-2} .

3. Metallic Conduction

Metals are conductors of electricity because of the relatively free movement of their electrons throughout the metallic lattice. This electronic conduction is called metallic conduction.

4. Electrolytic Conduction

Electrolytes in the form of solution or in the fused state have the ability to conduct electricity. In this case, the current is not carried by free electrons through the solution or through the fused electrolyte. Here, the current is carried by ions having positive and negative charges.



5. Ionization

Ionization is the process in which ionic compounds when fused or dissolved in water split up into charged particles called ions.



6. Electrolytic Cell

The movement of ionic charges through the liquid brought by the application of electricity is called electrolytic conduction and the apparatus used is known as electrolytic cell.

7. Electrolysis

The electrochemical reactions that occur at the electrodes during the electrolytic conduction constitute the phenomenon of electrolysis.

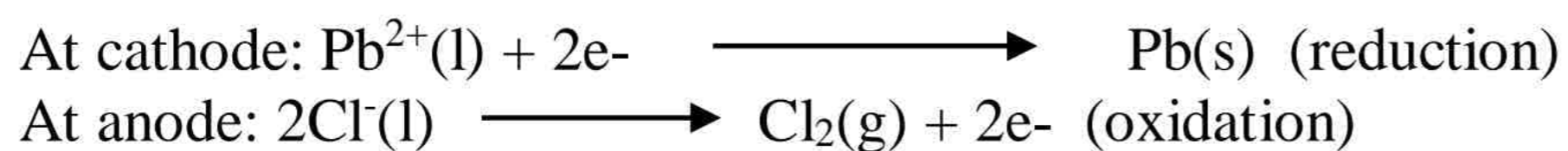

8. Electrode Potential

The potential set up when an electrode is in contact with one molar solution of its own ions at 298 K is known as standard electrode potential or standard reduction potential of the element. It is represented as E° .

9. Electrochemical Series

When elements are arranged in the order of their electrode potentials on the hydrogen scale the resulting list is known as electrochemical series.



CHAPTER 11

Reaction Kinetics

DEFINITIONS

Give definitions of the following terms:

1. Reaction Kinetics

The studies concerned with rates of chemical reactions and the factors that affect the rates of chemical reactions constitute the subject matter of reaction kinetics.

2. Rate of a Reaction

The rate of a reaction is defined as the change in concentration of a reactant or a product divided by the time taken for the change.

Rate of reaction = change in concentration of the substance/time taken for the change

Units: moles dm⁻³sec⁻¹

3. Instantaneous and Average Rate

The rate at any instant during the interval is called the instantaneous rate. The rate of reaction between two specific time intervals is called the average rate of reaction.

4. Law of Mass Action

It states that the rate of reaction is proportional to the active mass of the reactant or to the product of active masses if more than one reactants are involved in a chemical reaction.

5. Specific Rate Constant or Velocity Constant

The specific rate constant of a chemical reaction is the rate of reaction when the concentrations of the reactants are unity.

Let [A]=1 mol dm⁻³ and [B]=1 mol dm⁻³

Rate of reaction = $k \times 1^a \times 1^b = k$

6. Rate determining step

The slowest step is the rate determining step. For example,



This reaction has two steps



7. Reaction Intermediate

The reaction intermediate has a temporary existence and it is unstable relative to the reactants and the products. For example, NO₃ is the reaction intermediate in the reaction between NO₂ and CO.

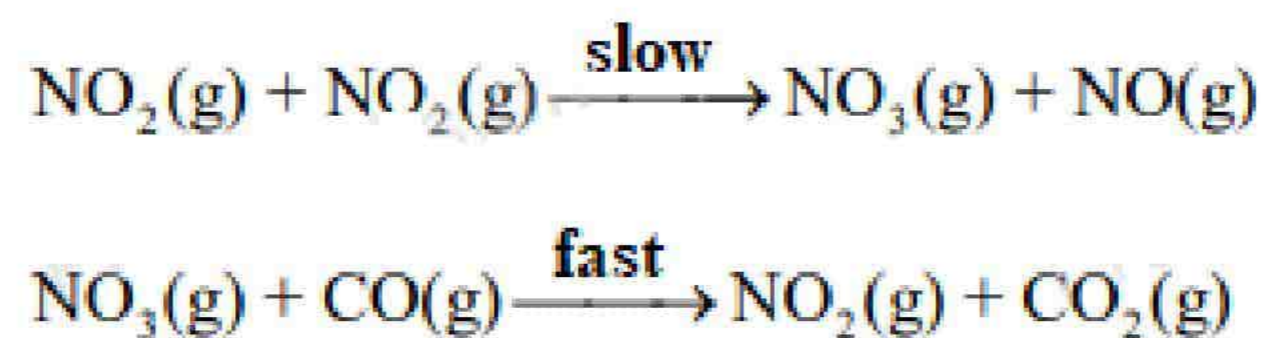

8. Half Life Period

Half life period is the time required to convert 50% of the reactants into products. For example, the half life period for the decomposition of N_2O_5 at 45°C is 24 minutes.

9. Activation Energy

The minimum amount of energy required for the reaction to take place is called activation energy.

10. Activated Complex

Activated complex is an unstable combination of all the atoms involved in the reaction for which the energy is maximum. It is a short lived species and decomposes into the products immediately. It has a transient existence that is why it is also called a transition state.

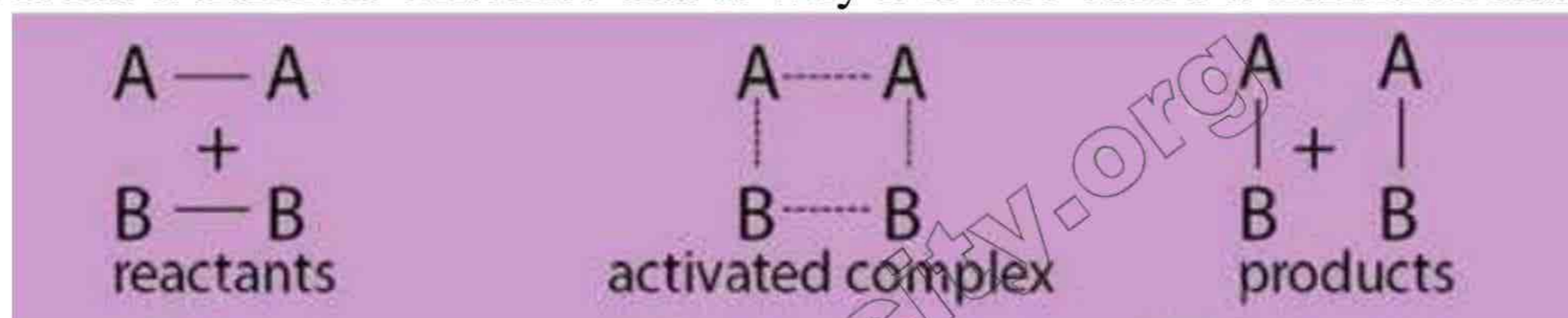

11. Catalysis

A catalyst is defined as a substance which alters the rate of a chemical reaction but remains chemically unchanged at the end of the reaction. For example, Pt is a catalyst for the reaction between H_2 and O_2 at room temperature.

12. Homogeneous Catalysis

In this process, the catalyst and the reactants are in the same phase and the reacting system is homogeneous throughout. For example,

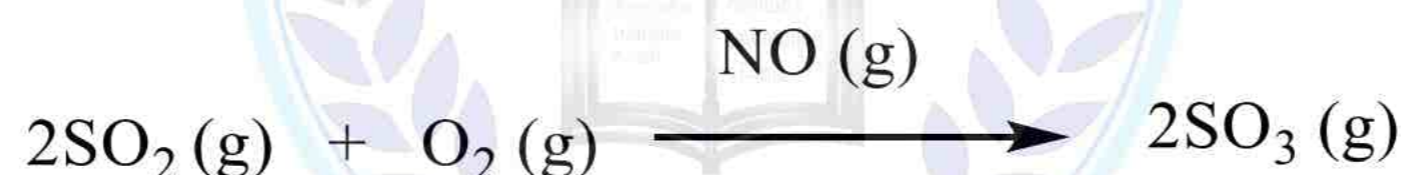

13. Heterogeneous Catalysis

In such systems, the catalyst and the reactants are in different phases. Mostly, the catalysts are in the solid phase while the reactants are in the gaseous or liquid phase. For example,



14. Activation of Catalyst

Such a substance which promotes the activity of a catalyst is called a promoter or activator. It is also called “catalyst for a catalyst”. For example, hydrogenation of vegetable oils is accelerated by nickel. The catalytic activity of nickel can be increased by using copper and tellurium.

15. Negative Catalysis

When the rate of reaction is retarded by adding a substance then it is said to be a negative catalyst or inhibitor. For example, tetraethyl lead is added to petrol because it saves the petrol from pre-ignition.

16. Autocatalyst

In some of the reactions, a product formed acts as a catalyst. This phenomenon is called autocatalysis. For example, when copper is allowed to react with nitric acid, the reaction is slow in the beginning. It gains the speed gradually and finally becomes very fast because of the formation of nitrous acid during the reaction.

